

Title:	CONCURRENCE IN AMENDMENT NO. 1 TO CONTRACT NO. CM-5400 WITH THE PERKIN- ELMER CO
Abstract:	
Pages:	0002
Pub Date:	10/20/1959
Release Date:	7/17/2001
Keywords:	OXCART SR-71 BLACKBIRD BLACK SHIELD A-12
Case Number:	F-2000-01388
Copyright:	0
Release Decision:	RIFPUB
Classification:	U



OKC-0059
Copy 2 of 3

20 October 1959

MEMORANDUM FOR THE RECORD

25X1A2g

SUBJECT : Concurrence in Amendment No. 1 to Contract No. OM-5400 with The Perkin-Elmer Corporation, Norwalk, Conn., Project OKCART

1. This memorandum contains a recommendation submitted for concurrence of the undersigned. Such recommendation is contained in Paragraph 5.

2. Contract No. OM-5400 covers engineering and designs for a photographic reconnaissance system, or systems, which will provide the OKCART vehicle with maximum capability. Amendment No. 1 to the contract provides for continuing the engineering and design work from 15 September 1959 to 31 October 1959.

25X1A6c

25X1A6c

3. Contract No. OM-5400 obligated \$180,000 chargeable to Fiscal Year 1959 GUSTO funds. By TWX ████████ 3092 the Contractor was authorized to continue the contract through 31 October 1959 at an additional approximate cost of \$74,700. Amendment No. 1 0328-0966-227 to Contract No. OM-5400 supersedes the authorization granted in TWX ████████ 3092 and obligates \$29,472 chargeable to Fiscal Year 1960 OKCART funds. The total of the funds obligated to Contract No. OM-5400 is therefore \$209,472. The additional work covered by Amendment No. 1 is included in approval granted by DEP 4-6866. By concurrence to this memorandum, the Comptroller signifies that sufficient funds are available for Amendment No. 1.

4. Certification of funds for this contract will be handled under the procedure approved by the Director of Central Intelligence on 15 December 1956 which, in effect, results in all covert expenses involving issuance of Treasury Checks being accumulated in a separate account within the Finance Division. The amounts in this account will be periodically scheduled for certification of the vouchers by the Director. This procedure eliminates the necessity for a separate certification of authority under Section 8(b) of Public Law 110, 81st Congress, (formerly 10(b) see 85-507 dtd. 7/7/58) for each contract.

DOCUMENT NO. 43
NO CHANGE IN CLASS. X
DECLASSIFIED
CLASS. CHANGED TO: TOP SECRET
REVIEW DATE: 2012
AUTHORITY: 18 CFR 1.1
REVIEWER: 010886



5. Concurrence in Amendment No. 1 to Contract No. CM-5400 is recommended.

SIGNED 25X1A9a

Contracting Officer, IFD

CONCURRENCES:

25X1A9a

SIGNED 10/20/59
Controller, IFD

25X1A9a

IFD

25X1A9a

Office of General Counsel

25X1A9a

DPD-DD, [redacted]:pf

Distribution:

- 1 - CM-5400
- 1 - Comp., DPD
- 1 - Chrono, OXC



Title:	ORGANIZATION AND DELINEATION OF RESPONSIBILITIES PROJECT OXCART
Abstract:	
Pages:	0004
Pub Date:	11/9/1959
Release Date:	7/24/2001
Keywords:	OXCART SR-71 BLACKBIRD BLACK SHIELD A-12
Case Number:	F-2000-01388
Copyright:	0
Release Decision:	RIFPUB
Classification:	U



~~SECRET~~

D
R
A
F
T

9 November 1959

ORGANIZATION AND DELINEATION OF RESPONSIBILITIES PROJECT OXCART

1. General direction and control of the Project shall be exercised jointly by the Director of Central Intelligence and the Chief of Staff, USAF, subject to guidance from higher authority and coordination with other departments of the Government as appropriate. They shall furnish policy guidance to lower echelons, ensure the conformity of operations under the Project with national policy, and make recommendations to higher authority on matters transcending their own authority. Further, it shall be their joint responsibility to resolve differences that may arise at lower staff and operating levels.

2. The following are the organizational elements which shall be responsible for the conduct of the Project:

a. There is in existence a Project Headquarters headed by a CIA Project Director. An Air Force officer is assigned as Deputy Project Director. Project Headquarters will establish an operational unit presently planned to be stationed in the Zone of Interior. This unit will be manned by USAF and CIA personnel in numbers, proportions, and skills as agreed between the Project Director and the Air Force Project Officer.

~~SECRET~~



- 2 -

b. All military personnel assigned for full-time duty to the Project will be carried on CIA rolls, chargeable to CIA, for a projected minimum of three years.

c. There has been established a separate Air Force Project Staff headed by a Project Officer who will act in the name of the Chief of Staff, USAF. The Project Staff will include selected officers designated by certain of the Deputy Chiefs of Staff to act as points of contact within their several offices.

3. The functions and responsibilities of these elements will be as follows:

a. The CIA Project Director and the Air Force Project Officers shall have primary responsibility for the development and execution of all activities concerning the Project within their own organizations; the resolution of differences that may arise at lower echelons; and the reporting of progress and the making of recommendations to their respective chiefs.

b. The Project Headquarters will be responsible for any continued research and development, operational planning, and the direction and control of activities in the final operational phase of the Project when overflights are being launched.

c. The Air Force Project Staff shall be responsible for implementing plans approved by the CIA Project Director and the Air Force Project Officers, and arranging for Air Force support of Project activities which can appropriately be furnished through staff channels or by other Air Force commands.



- 3 -

d. Security of this project within the DOD will be the responsibility of the Air Force Project Officer. All clearances for personnel within the DOD will be approved in advance and monitored by the Air Force Project Officer.

4. Activities under this Project fall into three phases. These overlap one another in time but may be distinguished on the basis of the kinds of activities involved in each. The following are the specific authorities and responsibilities of the several organizational elements in the successive phases of the Project:

a. The first phase is that in which the major activities are: research and development, procurement, the construction and activation of a test and training base, the testing of equipment, and operational planning. The Project Director shall have control of these activities including the planning and recruiting of personnel under his control. The Air Force will provide and coordinate necessary Air Force support which will be a matter for informal agreement between the CIA Project Director and the Air Force Project Officer. Full and complete coordination of all Air Force elements during this phase is essential.

b. The second phase will be devoted to flight test and training. These activities will be conducted at the test and training base. The operational flight training will be conducted in accordance with syllabi and standards as mutually agreed between the CIA Project Director and the Air Force Project Office. Phase II



terminates with the decision that crews and equipment are operationally ready.

c. The third phase will be that of active operations. This phase follows the decision as to operational readiness. The final decision as to execution and timing of actual overflight missions shall rest with the CIA Project Director, subject to such guidance as he may receive from higher authority. Notification coordination and support procedures currently employed in Project OILSTONE will apply. The line of command shall be direct between operational units and the Project Director.

APPROVED FOR USAF:

APPROVED FOR CIA:

Date: _____

Date: _____



Title:	NOTES ON EXCART
Abstract:	
Pages:	0002
Pub Date:	6/3/1960
Release Date:	10/18/1999
Keywords:	NOTES DEVELOPMENTS U-2 INCIDENT OXCART
Case Number:	EO-1994-00347
Copyright:	0
Release Decision:	RIPPUB
Classification:	U



~~SECRET~~

412 AIR Case No. 94-350
Document No. 7

Copy No. /

3 June 1960

NOTES ON OXCART

In the light of the U-2 incident of 1 May and subsequent developments growing out of that incident, some thought may be given to Project Oxcart. The following are certain factors of that project that may be relevant to any review at this time.

1. The Oxcart vehicle will not make its first flight until May 1961. Considerable flight testing will be required and there is little likelihood that it will be ready for operational use until the spring of 1962. Until that time, no policy considerations with respect to the employment of the vehicle will arise.

2. The vehicle in question will operate from a base in the [redacted] It may be desirable to stage operations through [redacted] base. No use of other bases in [redacted] is contemplated. Since the vehicle will typically approach target areas [redacted]



1.5(c)
3.4(b)(1)

3. Excellent progress is being made for the goal of [redacted] This factor, together with mach 3.2 speed, is counted on to provide a degree of invulnerability to interception greater than the U-2 enjoyed when it first became operational.

1.5(c)
3.4(b)(1)

4. [redacted]

1.5(c)
3.4(b)(1)

5. Although the program is being carried forward with urgency, it does not involve significant amounts of overtime or other sizeable costs incurred in order to permit earlier delivery date. In other words there

APPROVED FOR RELEASE
OCT 1999 0624996

~~SECRET~~



~~SECRET~~

is little saving to be made in the over-all cost of the program by stretching it out over time. Even if it seemed likely that operational use would be delayed beyond the spring of 1962 by policy considerations, it would be desirable to achieve the earliest feasible first flight so as to allow the maximum opportunity for the flight testing and check out of the vehicle and its sub-systems. Basically, of course, the reason for urgency is the desire to have a capability in hand at the earliest practicable date whatever the ultimate use of the capability.



6. Funding for FY-1961 is completely arranged within existing budgets. [REDACTED]

1.5(c)
3.4(b)(1)

7. The major precaution that would seem to be called for under present circumstances is the strictest possible security to conceal the fact that this program is in progress. To that end, [REDACTED]

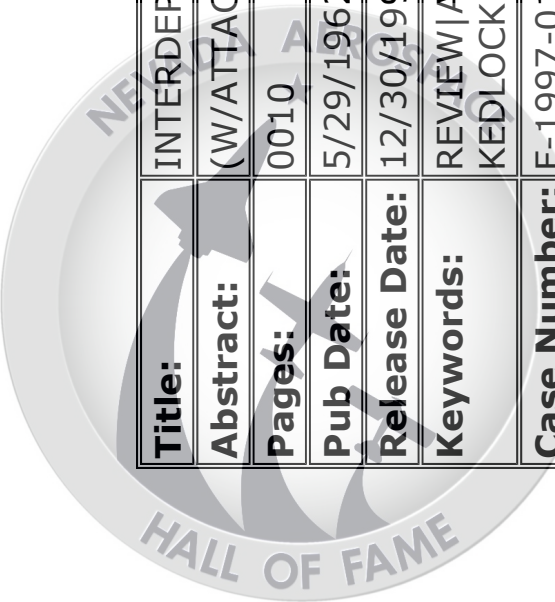
[REDACTED] Whether or not this particular step is taken, all witting individuals are being reminded of their security obligations.

1.5(c)
3.4(b)(1)

~~SECRET~~



Title:	INTERDEPARTMENTAL COVER SUPPORT FOR PROJECT OXCART
Abstract:	(W/ATTACHMENTS)
Pages:	0010
Pub Date:	5/29/1962
Release Date:	12/30/1998
Keywords:	REVIEW AIRCRAFT PROJECT OXCART INTERDEPARTMENTAL NRO PROJECT KEDLOCK
Case Number:	F-1997-01869
Copyright:	0
Release Decision:	RIPPUB
Classification:	U



~~TOP SECRET~~

Cover

This document contains information
referring to Project SECRET

OXC-3562
Copy No. 2

Dr. Charyk

~~TOP SECRET~~

754828

4



CENTRAL INTELLIGENCE AGENCY
WASHINGTON 25, D. C.

~~TOP SECRET~~

OXC-3562

Copy 2

20 MAR 1962

MEMORANDUM FOR : Joseph V. Charyk
Under Secretary of the Air Force

SUBJECT : Interdepartmental Cover Support for Project OXCART

REFERENCE : Memo for Under Secretary of the Air Force from DD/R,
Dated 26 February 1962; Same Subject (OXC-3084)

1. Submitted herewith for your review and concurrence is a revised version of the OXCART cover plan which has evolved from a re-examination of the original basic premise that the program, if necessary, would be related to an Air Force interceptor-type aircraft. It should be noted that any "fall-back" explanation of the Project would be taken only if our original position of "no comment" should become untenable.

2. As you know, the actual flight of the aircraft caused all concerned to further scrutinize the cover story, and it was readily apparent that the Air Force interceptor story had obvious loopholes. Primarily, it did not explain the following fundamental questions among several:

a. Why is testing of a type normally accomplished at
Edwards Air Force Base [REDACTED]

b. What is the source of funds for the Project?

c. Why was sole source procurement exercised?

d. What are the reasons for such tight security?

3. Accordingly, there is attached hereto a further revision of the OXCART Cover Plan which is submitted for your review and Department of the Air Force concurrence.

~~TOP SECRET~~

75482



4. This proposal does not change the basic philosophy of "no comment" to routine requests or probes for information. It does alter the fall-back position from interceptor-type aircraft to a Department of Defense research program directed toward a multipurpose, advanced research, satellite launch system (recoverable booster). This approach seems to provide optimum answers to the questions in paragraph 2 above, e.g.:

a. Being in the satellite field, it does not necessarily follow that the testing would have to be performed at Edwards Air Force Base.

b. The Defense Department can explain that the money was spent for procurement of aircraft through a classified mechanism for security reasons and in the national interest.

c. Lockheed Aircraft Corporation's unique experience in advanced aircraft (F-104) and space-satellite fields makes Lockheed particularly qualified for the job of developing a multipurpose advanced aircraft with a special capability as a recoverable booster for a satellite launch system. Additionally, Mr. C. L. Johnson is the most experienced hand in "skunk work" operations. This includes direct control and command from the top (Mr. Johnson) to the working personnel, as well as a direct line to Project Headquarters. It also provides the security, expeditious action, minimum cost, and personnel management required for this type of program.

5. In addition to your concurrence, any suggested amendments or other comments would be appreciated.

HERBERT SCOVILLE, JR.
Deputy Director
(Research)

CONCURRENCE:

Joseph V. Charyk

JOSEPH V. CHARYK
Under Secretary of the Air Force

Attachment
OXCART Cover Plan



~~TOP SECRET~~

Attachment
OXC-3562
Copy 2

INTERDEPARTMENTAL COVER SUPPORT TO PROJECT OXCART

I. PROJECT MISSION

To covertly develop and flight test a newly designed, high performance aircraft having a photographic capability.

- II. A. To conceal the OXCART reconnaissance development effort from unauthorized disclosure.
- B. To conceal specific state-of-the-art accomplishments.
- C. To conceal the number of aircraft under procurement.
- D. To conceal intelligence community (and particularly C.I.A.) participation in the development and ultimate utilization of the OXCART vehicle.
- E. To protect the existence of the OXCART vehicle from public disclosure until observed during some phase of the flight test program.

III. GENERAL COVER PLAN

The development and flight test operations of the mission vehicle will, for cover reasons, be considered a Department of Defense research program being directed toward a multipurpose, advanced research, satellite launch system. The research program will, when necessary, be described as being under the sponsorship of the Department of Defense with control and test operations being supervised by the Department of the Air Force. The details of the

~~TOP SECRET~~



program will be highly classified and access to any and all information pertaining thereto will be limited and controlled under a strict "need-to-know" policy with access and ostensible clearance authority resting with the Under Secretary of the Air Force.

IV. IMPLEMENTATION

To control public statements and unofficial disclosures pertaining to the aircraft, systems development and flight test operations government personnel and all contractors will limit their discussions of matters relating to the program to persons who have been properly OKCART-cleared and approved for access to such information.

In time, mishap to the mission aircraft or some serious inadvertent disclosure may arouse public interest and reaction to the degree that some form of official statement or explanation will become necessary. Each incident will be evaluated by pre-designated CIA and DOD personnel who will determine, and recommend to the Project Director, and to the Under Secretary of the Air Force an appropriate reaction. The sole spokesman for public release of information will be the Under Secretary of the Air Force.

Incidents arising, such as press inquiries or "educated" speculative articles appearing in or reported by the various news

~~TOP SECRET~~



~~TOP SECRET~~

Attachment
OXC-3362
Page 3
Copy _____

media, will not in themselves be sufficient cause for public responses. Inquiries directed to contractors or Government agencies including their personnel, will not be answered with other than a statement that this is a classified government project. If pressed further, an immediate request for guidance will be made to the C.I.A. Project OXCART Headquarters. All such inquiries will be reported to Project Headquarters in any case.

V. INCIDENTS ON LOCATION

[REDACTED]

If the aircraft has not been identified by uncleared personnel, it will be described as one of the "Century" series and not the mission aircraft.

VI. INCIDENTS OFF LOCATION

See Enclosure #2.

VII. PERTINENT COVER STORIES TO BE DISSEMINATED BY RESPONSIBLE ACTION OFFICERS ARE INDICATED BELOW

A. General Press and News Media Inquiries

Cover Story

See Enclosure #1.

~~TOP SECRET~~



~~TOP SECRET~~

Attachment
OXC-3562
Page 4
Copy _____

2. Responsible Action Office

Department of Defense (Under Secretary of the Air Force)

3. Coordinating Offices

Central Intelligence Agency (Deputy Director, Research)

Department of Defense (Under Secretary of the Air Force)

B. Incidents

1. Cover Story

See Paragraphs V and VI above.


2. Responsible Action Office

Same as VII-A-2 above.

3. Coordinating Offices

Same as VII-A-3 above.

VIII. The following named individuals are being furnished a copy of this document for purposes of internal coordination with cleared personnel within their respective departments. It is requested that a record be maintained of personnel who have been so briefed.

Dr. Joseph V. Charyk	- Department of Defense
Dr. Hugh Dryden	- National Aeronautics and Space Agency
Mr. Sa'eeb Halaby	- Federal Aviation Administration
	- Central Intelligence Agency
Gen. Maxwell Taylor	- Military Representative of the President

~~TOP SECRET~~



~~TOP SECRET~~

REF ID: A66666
OAO-3562
Page 5
Copy _____

IX. The Central Intelligence Agency will notify each Agency of any change to this plan and in turn requests that any suggested alterations be coordinated with C.I.A. for concurrence prior to implementation.

~~TOP SECRET~~



Attachment
OKO-3962
Enclosure #1
Copy _____

PRESS RESPONSE WITHOUT INCIDENT (To be released only by the Under
Secretary of the Air Force)

Within the past year, the Department of Defense has initiated a program directed toward improving methods of protecting sensitive information. Where practical, the Department has kept secure details as to missile firings, prohibited closeup photography of our missiles, space vehicles and supporting facilities, and has not announced when important system tests are being held. The primary purpose has been to avoid giving progress details on defense systems development which, under previous procedures, made such information available to foreign intelligence agents; permitting them to make detailed weapon system analyses.

Accordingly, current policy precludes release of any information about the present project other than that it is a classified, advanced research and development program under Department of Defense sponsorship with the Department of the Air Force exercising supervision of control and test operations.

FALL BACK POSITION

If news media pressures are of sufficient magnitude to warrant and if it is the determination of C.I.A. and D.O.B. reviewing authorities that circumstances make it desirable, a fall-back position can be taken which would include the additional disclosure that it is a vehicle which is related to the development of a satellite launch system.

~~TOP SECRET~~



~~TOP SECRET~~

Attachment
OIC-3562
Enclosure #2
Copy _____

PRESS RESPONSE TO MINEAP (UNCLASSIFIED)

The vehicle which (crashed) (made a forced landing at _____) on (_____) was an experimental prototype being used in a Department of Defense research program. The vehicle was on a routine test flight at the time.

The research and flight test operations are being conducted under the supervision and control of the United States Air Force [REDACTED]

[REDACTED]

Details concerning test objectives and vehicle specifications are classified.

[REDACTED]

FALL BACK POSITION

It is anticipated that only the most extreme circumstances would require a release of information in excess of the above statement. But, if necessary, any additional release should be in the direction of the normal, controlled cover story. Therefore, any release beyond the above would be the primary PRESS RESPONSE WITHOUT INCIDENT (Enclosure #1) followed--again, if completely unavoidable--by its own FALL BACK POSITION statement.

~~TOP SECRET~~



Title:	SUMMARY OF MEETING WITH SECRETARY MACNAMARA AND SECRETARY GILPATRIC, GENERAL CA
Abstract:	
Pages:	0003
Pub Date:	7/6/1962
Release Date:	4/28/2004
Keywords:	MCCONE OXCART MCNAMARA GILPATRIC
Case Number:	F-1997-00260
Copyright:	0
Release Decision:	RIPPUB
Classification:	U



(b) (1)
(b) (3)
(S)

APPROVED FOR RELEASE
DATE: FEB 2004



6 July 1962

Summary of meeting with Secretary McNamara and Secretary Gilpatric, General Carter and Mr. McCone on 5 July 1962


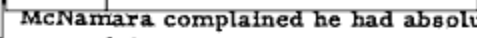
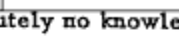
Held for the purpose of reviewing recent discussions with Killian Board, Bureau of the Budget and others concerning intelligence community problems and the coordination of the Community

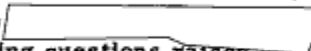
1. The Honolulu meeting on Southeast Asia will be called by McNamara about ~~February~~ 24th, exact date to be established. FitzGerald most welcome; McCone welcome but not necessary for him to attend.

July 24

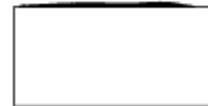
ACTION: Notify FitzGerald. Date of this meeting remains uncertain. He should be prepared to attend.

2. McNamara discussed at length the absence of meaningful intelligence on progress or lack of progress in Southeast Asia. McCone reported an intelligence effort substantially as reported to Special Group on 28 June, commenting in particular that both military and CIA had taken constructive steps but that no meaningful intelligence could be expected for a few months

  
McNamara complained he had absolutely no knowledge as to the success of the strategic hamlet project, whether advancing or standing still or going backward; whether accepted by SVN population; and expressed uncertainty concerning the effectiveness of strategic hamlets against Viet Cong actions.

ACTION: DCI agreed to  file an immediate report answering questions raised by McNamara. DDCI to handle.

3. DCI noted General Carroll's request re organization of the USIB indicating this should not take place prior January, 1963. Also DCI reviewed Service intelligence representatives' positions on major issues, all of which were familiar to McNamara. SecDef indicated that he felt parochial approach intelligence problems would not be corrected until DIA firmly established and USIB reorganized.



~~SECRET~~ [REDACTED]

4. DCI reviewed briefly status NSA and the COMINT/ELINT effort, referring to various statements made by Director of BOB and recorded in July 2nd Memorandum for the Record and the Killian Board, recorded June 26th, Memorandum to the President. DCI particularly emphasized reports made to Killian Board (but not to DCI) that NSA had indicated intention to increase personnel from [REDACTED] total for NSA and all Services to [REDACTED]. McNamara indicated very tight control of Defense intelligence community personnel, DIA billets to be filled so far as possible with equal reductions Service billets; no increases in Defense intelligence community personnel without specific approval of SecDef and he not inclined to approve increases. DCI indicated possibility of duplication in SIGINT effort, particularly in ELINT field, stating he intended conduct review at once. Also referred to Killian Board recommendation that entire unit SIGINT collection and processing should be controlled by NSA. DCI stated that careful control and direction of SIGINT collection and processing probably would reduce, rather than increase, billets. McNamara indicated absolutely no interest in DCI assistance in planning or management of Defense Intelligence Community activities, budget, personnel or operations.

ACTION: DCI initiate team to review SIGINT operations independently of SecDef and prepare recommendations to SecDef and President for implementing appropriate plans for centralized control of SIGINT activities centered in NSA, if study so warrants.

5. Reference Killian Board report, DCI reviewed NRO with particular reference to FIREFLY which obviously was handled "out of channel" by DOD. McNamara questioned use of OXCART, stating there existed a written commitment from Kennedy to Khrushchev that flying of manned aircraft over Soviet territory would not be undertaken by Kennedy Administration. McNamara expressed grave doubt on use of OXCART, and if done probably would have to be done without specific knowledge of President. McNamara further raised the question as to need of OXCART reconnaissance in view of approved satellite reconnaissance. McCone stated he had every intention of using OXCART and had so advised the President.

ACTION: DCI should immediately review all correspondence and commitments between the President and Khrushchev on this subject.

~~SECRET~~ - 2 - [REDACTED]

NEVADA AEROSPACE

HALL OF FAME

~~SECRET~~

6. DCI reviewed necessity of research audio-surveillance and urged SecDef support in this field, indicating close cooperation between CIA and DIA. Also reviewed BIGDISH which SecDef confirmed was cancelled. An announcement to be made.

7. DCI advised McNamara of proposed presentation of Soviet long-range capabilities, NIE 11-8 and suggested McNamara have available at the meeting summary of U.S. missile and bomber capabilities, '62, '64 and '67 as question would be raised. SecDef and DCI reviewed several schedules used as a basis for planning by SecDef. DCI noted all gave Soviets much higher capability than those contained in NIE 11-8.

8. DCI raised question of Cuban charges of military plane overflights out of Guantanamo, suggesting SecDef examine the matter carefully and issue appropriate denials.

9. In summary I feel that the SecDef has an agreed plan for the reorganization of the Defense intelligence community and he does not intend to expand the entire community; that the build-up of DIA would be coupled with a decrease in the Service individual intelligence efforts and personnel, that plans of reorganization extend over the next several months, that he has no immediate agreed plan with respect to the SIGINT activities and the role of NSA but is expecting General Blake to treat with this subject, that he is not particularly interested in DCI assistance on his internal problems and (although he did not express it) obviously feels that the DCI role should be confined to the interface between the Defense intelligence community and the balance of the National intelligence community. In this respect I feel that SecDef's views differ sharply from those of the President, the BOB and the Killian Board.

JOHN A. McCONE
Director

JAM

- 3 -

~~SECRET~~



Title:	PROPOSAL FOR SURFACING AN LRI PROTOTYPE AS COVER FOR THE OXCART PROGRAM - PROJE
Abstract:	(BEST COPY AVAILABLE)
Pages:	0015
Pub Date:	4/10/1963
Release Date:	12/30/1998
Keywords:	CONSTRUCTION PROPOSAL PROJECT OX CART NRO FLIGHT TESTING FLIGHT TRAINING LRI PROTOTYPE PROJECT KEDLOCK
Case Number:	F-1997-01869
Copyright:	0
Release Decision:	RIPPUB
Classification:	U

CENTRAL INTELLIGENCE AGENCY
WASHINGTON 25, D. C.

10 APR 1963

MEMORANDUM FOR: Director, National Reconnaissance Office

SUBJECT: Proposal for Surfacing an LRI Prototype
as Cover for the OXCART Program

1. The OXCART program initiated in 1959, has during the ensuing years and up to the present time progressed through the development and initial construction phase and, surprisingly, through an entire year of flight testing and flight training without a single exposure or significant security breach which resulted in attracting public attention to the program.
2. This accomplishment becomes even more remarkable when it is appreciated that practical considerations have forced us to adhere to a pattern that is widely known and associated with the U-2 program and involving such elements as Lockheed, Kelly Johnson, [redacted] etc.
3. This record, which has exceeded our most optimistic expectations, was not established through fortuitous circumstance and at least passing recognition should be accorded those who have had responsibility for the security of the program since its inception.
4. With the advent of the R-12 procurement, it should be recognized that the program cannot be contained in the same manner as in the past. More than 7,000 persons in industry already are either fully or partially cleared. In addition, the increased frequency of flights will almost inevitably result in an incident under circumstances that we may not be able to control. The magnitude of the program in itself negates any effort at complete concealment, and there is already [redacted]

Copy 2

*Can we try to make
the President's decision make
on the R-12 in Feb - approx
strongly by CIA*

NEVADA AEROSPACE

HALL OF FAME

an awareness in the aviation industry that Lockheed is engaged in a highly classified project of a unique nature. (A summary of examples of this awareness has been prepared by the Security Branch, OSA, and is attached at Tab A.) It must be assumed that public exposure is only a matter of time and steps must be taken now to prepare to meet this contingency and to protect the OXCART phase of the program.

5. In addition to concealing the true mission of the OXCART vehicle and plausibly ascribing to it a different purpose, there is the more difficult and potentially explosive political problem of explaining and justifying the limited competition procurement of the aircraft and the secrecy which cloaked its development. The possible political connotations of the latter will almost certainly not go unnoticed by those Members of Congress who are unwitting of the program, and the resultant clamor for investigation could quickly get out of control unless effective measures are taken beforehand to cope with such a development. The current TFX controversy has further compounded and accentuated this aspect of the problem. To a lesser degree, but still of considerable concern, is the anticipated reaction of the technical press and possibly some components of the aviation industry itself.

6. Our success to date in protesting the OXCART/AE 12 programs from public exposure is cited as an argument in favor of continuing our present policy without change. Under this concept we would not voluntarily surface any part of the program until forced to do so by some untoward incident or compromise.

7. Conversely, it is argued that such a course deprives us of the selection of the time and circumstances of such surfacing and also deprives us of the psychological advantages inherent in a voluntary surfacing as opposed to a situation in which it will be obvious to everyone that we are being forced by circumstances beyond our control to explain belatedly a program which we would have preferred to conceal from public view.

8. Whichever course is selected--i. e., controlled or uncontrolled surfacing--the problem of providing a plausible cover story is the same. The elements of the cover story would be identical

fact - it could be an illusion

In each instance; however, it seems logical that the plausibility would be significantly enhanced if the surfacing were voluntary. On balance, we conclude that a controlled surfacing offers advantages which outweigh the benefits deriving from our present policy which is becoming more untenable with the elapse of time and increased tempo of operations.

9. The cover story which will be employed in surfacing the AF-12 portion of the program must contain as many elements of truth as possible, short of jeopardizing the OXCART version. With this as a primary consideration, it becomes more and more obvious that the best solution is to surface the long-range interceptor prototype, the first one of which will be available by approximately mid-July 1963.

10. It is proposed that the Defense Department announce that a prototype of a long-range interceptor developed by Lockheed Aircraft Company for the USAF will commence flight tests at Edwards AFB on or about 5 July 1963. Whether the LRI, currently designated the X-22, will go into full production will depend on the decision of the Secretary of Defense which, in turn, will be based on the results of a major study and evaluation of further AF interceptor needs currently underway at the Pentagon and due on the desk of Secretary McNamara early in June.

11. The announcement will further state that the LRI prototype is the result of a limited design competition between Convair and Lockheed in 1959 which resulted in the selection of the LAC design using the Pratt and Whitney J-58 engine. The stringent security measures applied to the development program from its inception resulted from a decision by the previous administration to deny to the Soviets critical information on our future air defense systems which could vitally affect their decisions with regard to offensive weapons systems and countermeasures. The program was reviewed by the present administration in 1961, and the decision was made to continue development of the aircraft under the same rigid security policy then in effect.

12. Armament is provided by the Hughes Aircraft Corporation and is a version of the ASG-18 long-range radar and GAR-9 air-to-air missile. This system has been undergoing tests in a B-58 at Edwards AFB for the past two years.

13. Performance figures on the LRI will not be revealed, and beyond this announcement the high security level that has characterized this development will be continued in order to protect performance information.

14. There remains the question as to the timing of the controlled surfacing. It would be desirable to have available, at the time of the announcement, a prototype which could be displayed at Edwards AFB. This would require a delay in surfacing the LRI at least until mid-July 1963. Assuming that the Senate TFX hearings will have been concluded by then, this would have the added advantage of surfacing under a more favorable climate than presently exists. If the disclosure were made in the midst of the TFX hearings, any effort by the Senate Committee to avoid its introduction into the controversy would be almost painfully obvious and probably futile.

15. Conversely, if we delay the surfacing, it is with the attendant risk that an incident may occur in the interim which would accrue from a controlled surfacing.

16. In either case, it is proposed that no mention will be made of the incident unless itself is compromised by the nature of the incident. If the latter should occur, the activity will be described as a highly classified research program under the sponsorship of the Department of Defense with control and test operations being supervised by the Department of the Air Force. No further disclosures will be made.

17. At the present time there are twenty-one Congressmen briefed on OXCART. They are primarily members of the House Armed Services and House Appropriations Committees, and members of the Senate Armed Services and Senate Appropriations Combined Subcommittees (See Tab B).

18. One favorable aspect of the program lies in the fact that it will be extremely difficult for any Congressman to make a partisan political issue of the subject. The limited design competition and rigid security policy were established during a Republican administration and endorsed and continued by a Democratic administration. Nevertheless, it appears highly desirable that prior to any announcement


being made some additional key members of Congress be fully briefed on the OXCART program. In this way it might be possible to quell any Congressional conflagration even before it started. Such briefings probably should include Senators McClellan, Dirksen, Mundt, and Goldwater, and Representative Halleck. It might also be advisable to solicit the recommendations of those Congressmen already briefed as to what other measures we might undertake to achieve our objectives with Congress.

19. It is not anticipated that the aviation industry in itself will constitute a major problem; however, it would be prudent to be prepared to brief the top men in certain aircraft corporations if there were indications of an unfavorable reaction. The technical press may attempt to make a cause celebre of the announcement, but in the absence of strong reaction from the industry and Congress, it is believed that the critical comments will be short-lived.

20. It should be noted that at present we have an agreed inter-departmental contingency plan for OXCART which has been reviewed and approved by such august bodies as the Special Group and the President's Foreign Intelligence Advisory Board. Although a number of persons have expressed reservations as to the plausibility of this plan, which relates the vehicle to an airborne satellite launch system, should an incident occur tomorrow we would have little choice but to proceed in accordance with the approved plan.

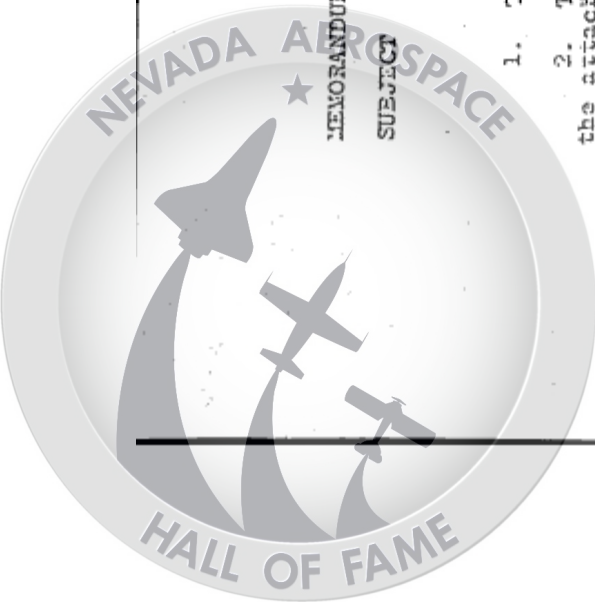
21. Recommendations:

- a. That the Ad Hoc Cover Committee be convened as soon as possible to consider the proposed surfacing of the LRI as a cover mechanism for OXCART.
- b. That the Committee resolve and make a recommendation on the timing of the surfacing.


HERBERT SCOVILLE, JR.
Deputy Director
(Research)

Attachments A & B





[Redacted]

MEMORANDUM FOR: Deputy Director (Research)

SUBJECT: Project OXCART
(Awareness in Aviation Industry)

1. This memorandum is for your information.
2. The OSA Security staff has invited to my attention the attached summary of examples of the increasing extent of awareness in uncleared industrial circles of Project OXCART.
3. Recently, it seems that almost daily a new indication appears that in the aviation business circles more and more people are putting two and two together regarding this Project. As touched upon in the attached, the sources interviewed mention that even without actual leaks of classified information there are enough indicators available to support a calculated estimate of the nature of Kelly Johnson's endeavors. Some of the "estimates" are right on the target.

4. The possibility of leaks can not be discounted, of course. In this regard as at 13 March 1963 the following number of persons were cleared for OXCART:

CIA
 Other U. S. Government
 Total U. S. Government
 Industry (Fully & Partially Cleared)
 Total Cleared

[Handwritten notes and signatures]

5. With KEDLOCK coming along it must be anticipated that the problem of containing information concerning the existence and status of OXCART and, of course, KEDLOCK, will be that much more difficult to handle.
6. OSA Security is "beating up" its staff and in addition to monitoring the security of these programs will

[REDACTED]

endeavor to react promptly to plug up leaks and "too close to the truth" speculations. You may desire, however, to invite to the attention of the Director, the information highlighted herein to ensure that he is aware of the climate in which we are endeavoring to protect these ultra-sensitive activities.

7. I have encouraged all elements of this Office to vigorously address themselves to this considerable problem to ensure that our maximum effort is riveted upon the best possible solution.

[REDACTED]
COLONEL, USAF

Assistant Director
(Special Activities)

Attachment, as stated

[REDACTED] (20 March 1955)

Distribution:

Copy 1 & 2 - DD/R
3 - AD/OSA
4 - DND/CSA
5 - PS/CSA
6 - [REDACTED]/CSA
7 - DD/OSA
8 - OD/OSA
9 - CD/CSA
10 - [REDACTED]/CSA
11 - ADMIN/OSA
12 - DD/Sec
13 - [REDACTED]/OSA
14 - [REDACTED]/OSA

NEVADA AIR FORCE

HALL OF FAME

1. North American Aviation, Los Angeles, California

Admiral John B. Pearson, USN (Ret.) VP (Development and Planning) North American Aviation, Los Angeles, California, was in April 1953. Incidental to his responsibilities with WPA (monitoring all military activities within American industry) he concluded a full year before that North American, Inc., was developing a supersonic Mach 2.4 - Mach 3, long range, high altitude (50,000-65,000 feet) aircraft which would probably be twin engine and have a dual mission, reconnaissance and intercept.

Basis for conclusion:

- c. Evaluation of United States Government's defense needs.
 - d. Recognizing the need and realizing that the F-100 program has been cancelled, he noted that no overt mention of a replacement was being made.
 - e. The infrequent appearances of Kelly Johnson during the past two years was an indication that he was actively engaged in a new program.
 - f. After the cancellation of the F-108, he determined that several of the people who were working on the GAR-9/ASC-10 in Hughes Aircraft were working on a hush, hush program. What he speculated to an old friend at Hughes that there was probably no current use of the GAR-9 unless Kelly Johnson was building something at Lockheed, the old friend was reportedly startled and changed the subject which Pearson took as another clue.
 - g. It was common knowledge that the J-53 program at Westinghouse was continuing as a production effort, with no published customer or use.
 - h. A budget analyst at North American advised that the previous year's budget failed to identify uses for \$150 million.
- Admiral Pearson at the conclusion of the discussion observed that the primary need in his opinion to preclude



further disclosures of confirmation of the Lockheed program would be the publication of a cover story for Kelly Johnson. He also suggested the possibility of considering briefing some aviation editors such as Marvin Miles of the Los Angeles Times.

2. Cross Country News, Fort Worth, Texas

Cross Country News article of 31 January 1963 (aeronautical newspaper published at Fort Worth, Texas):

"LOCKHEED SST SAID IN 4 STAGE. A HIGHLY GUARDED SECRET MAY BE REVEALED WITHIN THE NEXT FEW DAYS. LOCKHEED AIRCRAFT, BURBANK IS EXPECTED TO ANNOUNCE A NEW SUPERSONIC TRANSPORT, OFF THE DRAWING BOARDS, EVEN IN THE 4 STAGE LOCKHEED OFFICIALS SAY NOTHING. NO DETAILS CAME WITH THIS TIP, FROM SOURCES CONSIDERED VERY RELIABLE.

"HOWEVER, IF THE LOCKHEED SST IS FLYING, OR ALREADY FOR FLIGHT TESTS, IT MAY EXPLAIN WHY HARVEY HALABY, CHIEF OF THE FAA, ASKED THE SUPERSONIC ADVISORY GROUP, TO SLUSH DOWN ON THEIR \$1 BILLION BOMBARDIER PROJECT. GOAL HAS BEEN TO HAVE A US SST FLYING BY 1972. FRANCE AND BRITAIN ARE IN A JOINT VENTURE, EXPECTED TO HAVE A 1,400 MPH PASSENGER PLANE OPERATING BY 1970. THE US IS EXPECTING TO TEST THE 2,000 MPH RS-70, THIS SPRING.

"LOCKHEED MAY INDEED REPEAT THEIR SLOGAN 'LOOK TO LOCKHEED FOR LEADERSHIP', IF THEY BREAK THE WORLD MARKET WIDE OPEN WITH THE SST IN 1968."

3. Martin Co., Denver, Colorado

William Clegern, Assistant to Director, Advanced Technology, Martin Co., Denver, Colorado. During the week of 28 January 1963, Mr. Clegern in discussions before a group pointed out several areas in the design field in which his company had no particular interest. He observed that it might interest the group to know that Lockheed was working on a follow-on vehicle, a "super U-2" that would fly in excess of 100,000 feet at a speed of 3.2 Mach.





American Aviation, Inc., Burbank, California

Colonel John J. Smith, (AF Retired), Chief of Requirements and Director of the Strategic Air Command, Colinus Braun, ex-ASAC, and other personnel were present. Colonel Braun, ex-ASAC, Colonel and Thomas Collins, ex-ASAC, James Wallace, ex-ASAC, and other personnel were present. North American Aviation, Inc. CR-15 which was that they had deduced that Kelly Johnson had a plane using two J-35 engines, with a number of about 100 which were at altitude of 150 to 100 thousand feet. Kelly Johnson had jet were employed, CR-15 to 100 thousand feet in accelerated run jets were used. Kelly Johnson stated that the wings are made of stainless steel. About 65 feet long and the plane has been flying since the fall of 1953. It was the opinion of this group that the plane was similar to the plane that was built in the fall of 1953, and the engine was similar to the engine that was built in the fall of 1953. The plane was probably a two seater and the program had a budget of about \$200 million.

The process of their discussions was as follows:

Colonel Smith had experience in the early U-2 program. It was apparent that there was a need for an advanced aircraft with excellent performance in the Air Force, he had tried to build the AS-10 and was to the dropping of the F-105, he reported that the AS-10 was a very good other application of the AS-10 had been submitted.

They observed that the AS-10 was allotted to develop the J-35 engine and that they were justified unless there was some high altitude airplane available in which to install the J-35.

They also were aware of various aircraft personnel were cleared. Clearance also was supported their conclusion that the AS-10 was involved.

They concluded that it appeared to be about 1950 that the specifications were set in the Government's mind and such an aircraft would normally be made up of a number of small items, but not to include a major



Some of the better L/C engineers are known to have left their normal work and gone into a hush, hush project.

Use of liquid hydrogen and oxygen is published in secret documents available to NAA including destination of aircraft, gunnister, etc. It was observed that a considerable amount was going to [redacted] which they knew did not use much, if any, consequently, they concluded it must be [redacted] supporting the opinion that a flight test program must be underway.

Indications of subcontracting for precision valves for [redacted] front examinations and such valves would have no other application than for this type plane.

South American Aviation, Los Angeles, California

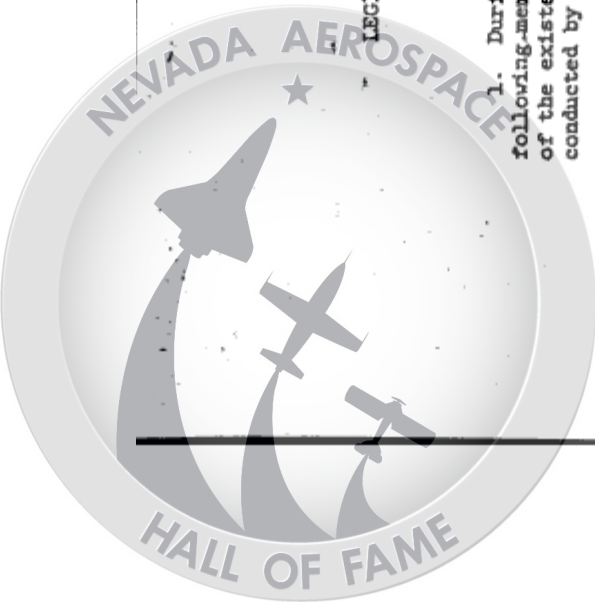
Weekly information summary for the week ending 15 March 1945 prepared by the Intelligence Staff for Distribution to the [redacted]. The summary included the following paragraph:

STUDY OF THE [redacted] WHICH AIRCRAFT (C) AFSC HAS BEEN [redacted] BY LOS ANGELES IMMEDIATELY [redacted] A [redacted] PLAN FOR A HIGH ALTITUDE RECONNAISSANCE AIRCRAFT. THIS EFFORT WAS INITIATED AT HIGH LEVEL AND IS [redacted] BEING PUSHED BY GENERAL [redacted]. WE UNDERSTAND [redacted] WAS [redacted] ALLOCATED TO THIS PROGRAM. [redacted] REQUIREMENTS [redacted] AS YET, BUT WE BELIEVE [redacted] STUDY WILL CALL FOR LONGER RANGE AND GREATER [redacted] AND ALTITUDE THAN THE CURRENTLY FLYING LOCKHEED RECON AIRCRAFT. LOS ANGELES DIVISION HAS BEEN DOING THIS WORK IN [redacted] RESEARCH [redacted] APPLICABLE TO THIS REQUIREMENT AND IS NOT FOLLOWING UP ON THIS NEW PLANNING STUDY. IN ADDITION TO LOCKHEED, BOEING AND REPUBLIC ARE REPORTED TO HAVE CURRENT STUDY EFFORTS [redacted] AT THIS REQUIREMENT."



Officials of USAF involved were interviewed on 18 March and discussed a file entitled, "Lockheed Project". It contained notes dated May 1951 indicating that Lockheed is working on a "developing" very high altitude, 130-140 mph and 70,000 ft aircraft, utilizing the ASC-13/GAR-9 for AEW (Airborne Early Warning) and high altitude reconnaissance. It was pointed out that the type of information was pieced together by bits picked up by the craft. It was also concluded that the J-55 engine has some new use for a high altitude plane to justify the funds put into it. The same was true of some existing purpose of the ASC-18 at Hughes Aircraft.





BRIEFED ON
LEGISLATIVE BRANCH PERSONNEL ~~CONFIDENTIAL~~ FOR OXCART
(AS OF 10 APRIL 1963)

1. During the period October 1960 to October 1962 the following members of Congressional Committees have become aware of the existence of Project OXCART during intelligence briefings conducted by the DCI and/or DDCI:

House Armed Services Committee

- Carl Vinson
- Frank Osmers
- Melvin Price
- Robert Wilson
- Leslie Arends
- Charles Bennett
- George Riddleston
- Edward Healey

Mr. Robert Smart, Chief, Counsel and Staff Director of this Committee has been formerly briefed on the program.

House Appropriations Committee

- Clarence Cannon
- George E. Mahon
- ~~John Fisher~~
- Gerald R. Ford, Jr.
- Harry R. Sheppard


Senate Armed Services and Senate Appropriations Combined Subcommittees

- Richard B. Russell
- Carl Hayden
- Harry F. Byrd
- Leverett Saltonstall
- John Stennis
- Mike Mansfield
- Milton R. Young
- Senator Robertson

Mr. William Darden, Staff member of the Senate Armed Services Committee has been formerly briefed on this project.

2. On 16 January 1963 the DCI found it necessary to apprise Senator Symington of Project "O".





Title:	MEETING WITH THE PRESIDENT - 5:30 - 15 APR 1963 IN PALM BEACH, FLORIDA
Abstract:	
Pages:	0002
Pub Date:	4/16/1963
Release Date:	4/28/2004
Keywords:	CUBA U-2 DONOVAN OXCART TFX LUNDAHL
Case Number:	F-1997-00260
Copyright:	0
Release Decision:	RIPPUB
Classification:	U

(b) (1)
(b) (3)
(S)

APPROVED FOR RELEASE
DATE: FEB 2004

1 used by NVA
4-16-63
33
16 April 1963

MEMORANDUM FOR THE FILE

SUBJECT: Meeting with the President - 5:30 - 15 Apr 1963
In Palm Beach, Florida

1. Mr. Lundahl gave a complete briefing on the latest satellite photography of the Soviet Union and both satellite and U-2 photography of Communist China.

2.



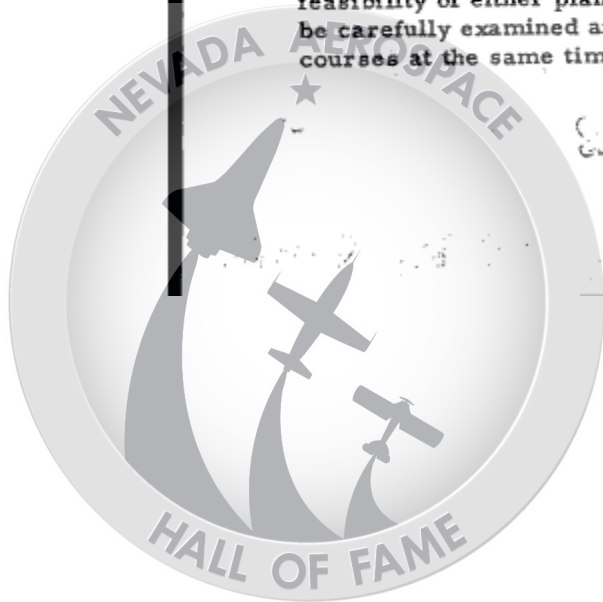
3. Discussed in some detail the Donovan negotiations in Cuba. Gave the President a [redacted] summary of the Donovan discussions and a copy of my memorandum of April 15th on Cuba. President raised the question of Miro Cardona, stated that Cardona had misrepresented the facts. I urged that the President not involve himself personally in a public argument with Miro Cardona.

I raised the question of the possibility of working on Castro with the objective of disenchanting him with his Soviet relations causing him to break relations with Khrushchev, to effect the removal of Soviet troops from Cuba, reorient his policies with respect to Latin America, and establish in Cuba government satisfactory to the rest of the Hemisphere. I explained to the President that the Cuban problem must be solved in one of two ways; either the manner outlined above or alternatively, by bringing consistent pressure of every possible nature on Khrushchev to force his withdrawal from Cuba, and then to bring about the downfall of Castro by means which could be developed after the removal of the Soviets troops (but not before) and thereafter establish a satisfactory government in Cuba. I stated to the President that we were studying both courses of action and I had not made up my mind concerning the feasibility of either plan. The President thought both approaches should be carefully examined and suggested the possibility of pursuing both courses at the same time. In any event it was decided that we should



(1)

(2)



~~SECRET~~

keep the Donovan channel open. I advised the President that Donovan has to return [redacted] at the end of the week and that I will see him privately prior to his departure.

4. The President and I talked at some length concerning sabotage in Cuba. I expressed grave doubts and pointed out the hazards from his standpoint in view of the stand-down of the hit-and-run exile operations, the danger of attribution, etc. The President seemed to question whether active sabotage was good unless it was of a type that could "come from within Cuba." I said this was very difficult [redacted] I said I thought a program should be engaged in only if it was an essential building block in an agreed program to remove the Soviets from Cuba and to take care of Castro.

5. Advised the President of my plans for a brief trip to Europe. Also advised him that I had delayed my departure for a few days in order to meet with the Killian Board on April 23rd. I repeated my very strong objections to the Killian Board report and that I felt the report should either be withdrawn from the Board or amended. The President urged that I not engage in a controversy over this report, he had decided not to circulate it, that only one copy was in existence, and as far as he was concerned he had dismissed the entire matter. I told the President I had not discussed the Board's report with the Board, but if they brought it up I intended to urge its amendment but would not engage in a controversy with the Board.

6. Discussed briefly the problems of Soviet leadership in the USSR and gave the President a copy of the paper on this subject.

7. Advised the President of the study of future satellite photography which I had initiated. It was obvious from our brief discussion on this subject that the use of the OXCART over Soviet territory was of great concern to him and he was most hopeful of improving satellite photography to a point where it would suffice our intelligence needs.

8. Briefly discussed the views of Mr. Kelly Johnson on the TFX and the Navy's plans to install a submarine research center on Andros Island in the Bahamas.

JAM [redacted]

~~SECRET~~



Title:	PROPOSAL FOR SURFACING AN LRI PROTOTYPE AS COVER FOR THE OXCART PROGRAM, (DELET
Abstract:	
Pages:	0003
Pub Date:	5/20/1963
Release Date:	12/30/1998
Keywords:	PROPOSAL PROGRAM OXCART NRO LRI PROTOTYPE PROJECT KEDLOCK
Case Number:	F-1997-01869
Copyright:	0
Release Decision:	RIPPUB
Classification:	U



CENTRAL INTELLIGENCE AGENCY
WASHINGTON 25, D.C.

[REDACTED]
Copy

10 JUL 1963

MEMORANDUM FOR: Director, National Reconnaissance Office

SUBJECT : Surfacing of LRI Prototype.

REFERENCE : Proposal for Surfacing an LRI Prototype as
Cover for the OXCART Program [REDACTED]

1. The referenced memorandum, dated 10 April 1963, outlined a proposal for the surfacing of an LRI prototype as a cover mechanism for the OXCART program.
2. As you will recall, immediately subsequent to your receipt of this proposal, an informal meeting was held to discuss the recommendations included therein and to determine a further course of action. It was concluded at that time that no further action would be taken on the recommendations until you had had an opportunity to discuss the merits of the proposal with Secretary McNamara and elicited his views on the subject. Since that time there has been no further exchange of correspondence on this subject and we are uncertain as to whether the problem has been discussed with Secretary McNamara and, if so, the results of such a discussion.
3. The purpose of this memorandum is to restate the grave concern expressed in our previous memorandum with regard to the possibility of an untoward incident which could result in an uncontrolled surfacing of the OXCART vehicle. Since that paper was written, there have been several minor incidents involving mechanical malfunctions and sightings of the A-12 which might have developed into serious problems had fortune not otherwise dictated. In addition, during this period, escalated activity in the R-12 procurement program has, as we anticipated, generated increasing speculation both in the industry and in the Air Force regarding many facets of the program.

[REDACTED]

3



[REDACTED]

4. In light of the foregoing, I feel that it is not only appropriate but essential at this time, to request a reconsideration of this problem by the NRO with a view toward making recommendations to the Ad Hoc Cover Committee and higher authorities as to whether we should continue with the currently approved contingency plan or take action to implement the proposed LRI surfacing. I would appreciate your comments at your earliest convenience.

[REDACTED]

HERBERT SCOVILLE, JR.
Deputy Director
(Research)

~~TOP SECRET~~

[REDACTED]



24 May 1963

MEMORANDUM FOR COLONEL JOHN MARTIN

SUBJECT: Surfacing of LRI Prototype

I have discussed this with the boss and he said he would talk this matter over again with Mr. McNamara and so advise. In the meantime, I pass this on to you for your safekeeping.

1 Atch
Memo for Dir. NEO
20 May 63
Cy 3, Series A

[REDACTED]
Colonel, USAF
[REDACTED]

[REDACTED]



~~TOP SECRET~~

Copy 2 of 2 Copies

Title:	WEEKLY ACTIVITY FOR OXCART PROGRAM - WEEK ENDING 2 JUNE 1963
Abstract:	
Pages:	0002
Pub Date:	6/4/1963
Release Date:	7/24/2001
Keywords:	OXCART SR-71 BLACKBIRD BLACK SHIELD A- 12
Case Number:	F-2000-01388
Copyright:	0
Release Decision:	RIFPUB
Classification:	U



325

Approved For Release 2000/05/05 : CIA-RDP71B00590R000200030012-9

CLASSIFIED MESSAGE

DATE 2202Z 04 JUN 63

~~SECRET~~

1	4
2	6
3	8

TO : DIRECTOR
 FROM : ██████████ 25X1A
 ACTION: OSA (1-15)
 INFO : S/C (16)

123 Crash File

PRIORITY

IN--78656
25X1A

25X1A TOR: 2326Z 04 JUN 63

TO PRITY ██████████ INFO CITE ██████████ 6919

OXCARD

TO DR. SCOVILLE INFO JOHN PARANGOSKY FROM KELLY JOHNSON

SUBJECT: WEEKLY ACTIVITY FOR OXCART PROGRAM - WEEK ENDING 2 JUNE 1963

NO FLIGHTS ACCOMPLISHED THIS PERIOD. SINCE NO REPORT WAS SUBMITTED LAST PERIOD, IT SHOULD BE NOTED THAT NINE FLIGHTS WERE ACCOMPLISHED IN THAT PERIOD. THIS MADE TOTAL FLIGHT HOURS TO DATE 332 HOURS 27 MINUTES. TOTAL NUMBER FLIGHTS TO DATE NOW 236. DURING PREVIOUS PERIOD, ONE FLIGHT WAS MADE ON AIRCRAFT NUMBER 121, AND FOUR FLIGHTS EACH ON AIRCRAFT NUMBER 123 AND NUMBER 124. UNFORTUNATELY, AIRCRAFT NUMBER 123 CRASHED AND WAS DESTROYED ON LAST FLIGHT WHEN PILOT BAILED OUT ON FINAL LEG OF INERTIAL NAVIGATION SYSTEM PROFICIENCY FLIGHT. CIRCUMSTANCES LEADING TO BAILOUT NOW BEING INVESTIGATED BY FORMAL ACCIDENT BOARD. ALL WORK TERMINATED AT ██████████ AT CLOSE OF WORK DAY 29 MAY TO ALLOW PERSONNEL LONG WEEKEND IN CONJUNCTION WITH MEMORIAL DAY HOLIDAY.

25X1A

AIRCRAFT NUMBER 121 MADE ONE FLIGHT IN PREVIOUS PERIOD TO EXTEND SPEED ALTITUDE ENVELOPE. MAXIMUM SPEED ATTAINED WAS 2.42 MACH,

Approved For Release 2000/05/05 : CIA-RDP71B00590R000200030012-9

REPRODUCTION BY OTHER THAN THE ISSUING OFFICE IS PROHIBITED. Copy No. 12



25X1A

██████████ 6919 (IN--78656)

~~SECRET~~

PAGE TWO

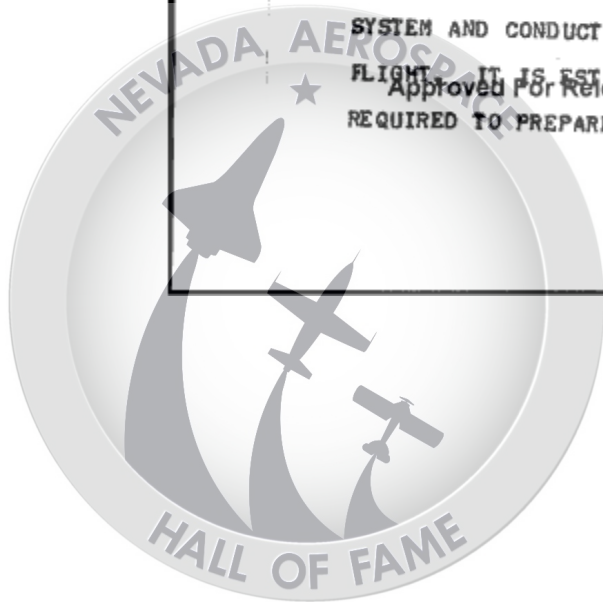
WHERE ACCELERATION TERMINATED DUE TO POPPED SHOCK IN INLET DUCT. SUBSEQUENT INVESTIGATION REVEALED ATTITUDE SENSOR FOR INLET SPIKE CONTROL HOOKED UP IMPROPERLY, WHICH RESULTED IN SCHEDULE SHIFT ON SPIKE CONTROL. THIS WAS CAUSE FOR SHOCK POPPING AT INLET DUCTS. SUBSEQUENT INSTRUMENTATION DIFFICULTIES DELAYED FURTHER FLYING UNTIL AIRCRAFT NUMBER 123 ACCIDENT OCCURRED, GROUNDING ALL AIRCRAFT. FURTHER SPEED ALTITUDE ENVELOPE EXTENSION EFFORTS WILL BE MADE AS SOON AS IT IS PERMISSIBLE TO FLY AGAIN.

PREFLIGHT GROUND RUNS ACCOMPLISHED ON AIRCRAFT NUMBER 122 THIS PERIOD AFTER COMPLETING ALL MODIFICATIONS AND NACELLE CLEANING REQUIRED TO PREVENT ENGINE FOREIGN OBJECT DAMAGE. GROUND RUNS COMPLETED WITH NO SIGN OF COMPRESSOR FOREIGN OBJECT DAMAGE. AIRCRAFT NOW READY FOR FLIGHT WHEN FLYING IS TO BE RESUMED.

25X1A

FOREIGN OBJECT DAMAGE PREVENTIVE MODIFICATIONS AND NACELLE CLEANING ARE APPROXIMATELY 50 PERCENT COMPLETE ON AIRCRAFT NUMBER 125 AND ALMOST 100 PERCENT ON AIRCRAFT NUMBER 126. AIRCRAFT NUMBER 126 IS NOW READY TO HAVE THE ENGINES INSTALLED AND WILL BE READY FOR FLIGHT IN FORTHCOMING PERIOD. ██████████ TELEMETRY PACKAGE HAS BEEN FITTED IN AIRCRAFT NUMBER 126 AND SHOULD BE READY FOR HIGH ANGLE PASSES SHORTLY AFTER INITIAL FLIGHTS. AIRCRAFT NUMBER 125 IS NOT SCHEDULED TO FLY FOR AT LEAST ANOTHER WEEK.

AIRCRAFT NUMBER 127 IS BEING ASSEMBLED AND CHECKED OUT IN ACCORDANCE WITH STANDARD FUNCTIONAL TEST PROCEDURES. IT WILL BE NECESSARY TO FINISH ASSEMBLY, WORK NACELLE MODIFICATIONS AND SCREENS TO PREVENT ENGINE FOREIGN OBJECT DAMAGE, CHECK OUT FLIGHT CONTROL SYSTEM AND CONDUCT MANY FUNCTIONAL TEST PROCEDURES PRIOR TO FIRST FLIGHT. IT IS ESTIMATED THAT 15 MEN AND 1000 HOURS OF WORK WILL BE REQUIRED TO PREPARE THE AIRCRAFT FOR FLIGHT.



Title:	SUBJECT IS PROGRESS REPORT ON ACCIDENT INVESTIGATION.
Abstract:	
Pages:	0004
Pub Date:	6/5/1963
Release Date:	7/24/2001
Keywords:	OXCART SR-71 BLACKBIRD BLACK SHIELD A-12
Case Number:	F-2000-01388
Copyright:	0
Release Decision:	RIFPUB
Classification:	U



327

Approved For Release 2000/05/05 : CIA-RDP71B00590R000200030010-1

CLASSIFIED MESSAGE

DATE 0351Z 05 JUN 1963

~~SECRET~~

1	4
2	8
3	6

TO : DIRECTOR
 FROM : ██████████ 25X1A
 ACTION: OSA (1-15)
 INFO : S/C (16)

123 crash file

Empty rectangular box

PRIORITY

IN 78674
25X1A

TOR: 0532Z 05 JUN 1963 25X1A

TO PRITY ██████████ 25X1A INFO ██████████ CITE ██████████ 9766

OX CART
NO NIGHT ACTION

SUBJECT IS PROGRESS REPORT ON ACCIDENT INVESTIGATION.

1. AT 1500 HOURS 3 JUN 63, BOARD MET WITH LEADERS OF VARIOUS TECHNICAL GROUPS. EACH LEADER BRIEFED BOARD ON PROGRESS TO DATE. ITEMS WERE SUBSTANTIALLY AS FOLLOWS:

25X1A

A. OPS AND WITNESS GROUP: RESULTS OF TWO SPECIFIC FLIGHT TESTS FLOWN TODAY IN 124 BEING EXAMINED FOR APPLICABLE DATA. LIST OF SPECIFIC QUESTIONS TO BE ASKED ██████████ IN LIGHT OF RECENT FINDINGS BEING COMPILED. LIST NOT YET COMPLETE. REMAINDER THIS GROUP'S FINDINGS BEING FINALIZED FOR SUBMISSION TO COORDINATING COMMITTEE ON 5 MAY.

B. STRUCTURES, EXPLOSION, FIRE GROUP: EXAMINATION OF WRECKAGE AND SCATTER PATTERN REVEALS NO EVIDENCE OF STRUCTURAL FAILURE NOR IN-FLIGHT FIRE. REPORT IN FINAL DRAFT FORM.

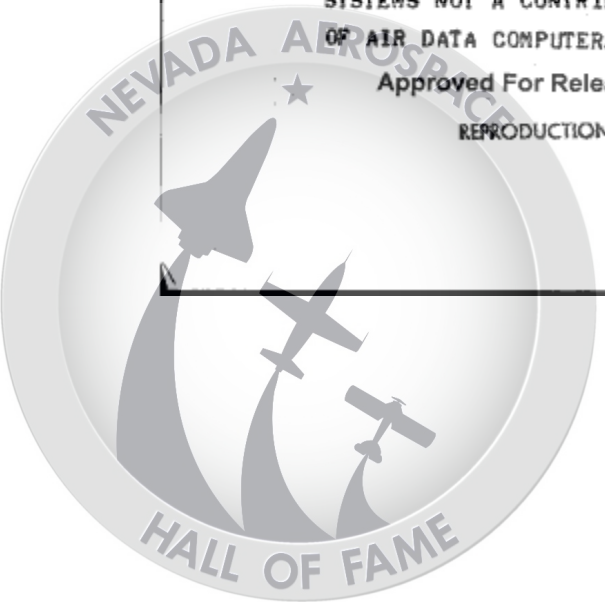
C. FLIGHT CONTROLS: PRELIMINARY FINDINGS SHOW FLIGHT CONTROL SYSTEMS NOT A CONTRIBUTING FACTOR IN ACCIDENT, WITH POSSIBLE EXCEPTION OF AIR DATA COMPUTER. REPORT NOW IN FIRST DRAFT.

Approved For Release 2000/05/05 : CIA-RDP71B00590R000200030010-1

REPRODUCTION BY OTHER THAN THE ISSUING OFFICE IS PROHIBITED. Copy No.

GROUP 1
Excluded from automatic
downgrading and
declassification

H H
S S



~~SECRET~~

25X1A

9766 (IN 78674)

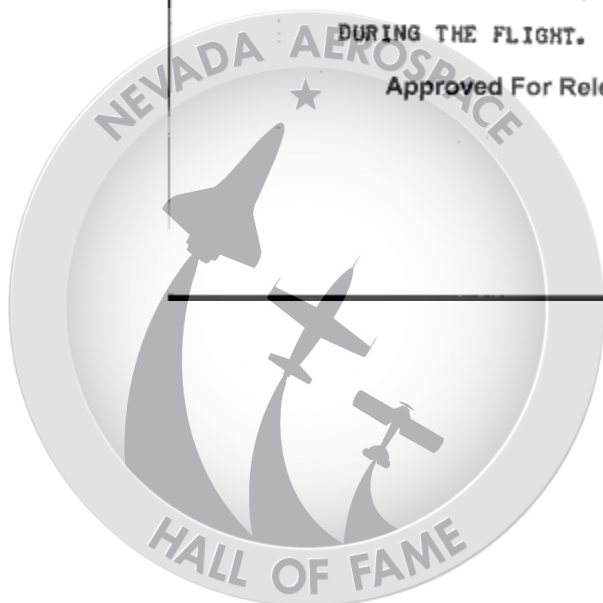
PAGE TWO

D. OXYGEN, PRESSURIZATION GROUP: THERE IS NO EVIDENCE TO DATE TO INDICATE THAT AN OXYGEN OR PRESSURIZATION MALFUNCTION MAY HAVE BEEN THE CAUSE OF THIS ACCIDENT. THE OXYGEN BOTTLES WHICH WERE USED TO SUPPLY AIRCRAFT 123 HAVE BEEN CHECKED AT MINUS 89 DEGREES F DEWPOINT. OXYGEN PURITY HAS BEEN CHECKED AND NO CONTAMINATION REPORTED. THERE IS NO EVIDENCE OF FIRE HAVING BEEN STARTED OR FED BY THE OXYGEN SYSTEM. THE SEAT DISCONNECT CLOSED THE OXYGEN LINES AFTER SEAT EJECTION AND THERE WAS NO FLOW OF OXYGEN INTO THE COCKPIT BEFORE IMPACT. RECENT FLIGHTS WITH MASKS AT 27,000 FEET CABIN ALTITUDE INDICATE THAT ADEQUATE OXYGEN WAS AVAILABLE. THE NBR 2 OXYGEN CYLINDER IS INTACT. ITS REDUCER AND RELIEF VALVE WERE RECOVERED AND LEAKAGE TESTS INDICATE 95 CCM LEAKAGE, WHICH IS STILL WITHIN SPECIFICATION. THE OUTPUT PRESSURE IS 112 PSI AT 1000 PSI INLET PRESSURE WHICH IS ALSO WITHIN SPECIFICATION. MAXIMUM ACCEPTABLE IS 140 PSI AT 100 CCM. THE NBR 1 CYLINDER WAS DESTROYED ON IMPACT. THREE PIECES OF THIS CYLINDER HAVE BEEN FOUND AND INDICATE THAT THE CYLINDER BROKE AFTER IMPACT.

E. FUEL: SAMPLES OF FUEL SIMILAR TO THAT USED ON THIS FLIGHT ARE DETERMINED TO HAVE 117 PPM SOLUBLE WATER CONTENT AND 0 PPM DISCRETE WATER CONTENT. TYPICAL SAMPLES OF FUEL FROM AIRPLANE 124 ARE DETERMINED TO HAVE A MAXIMUM OF 108 PPM SOLUBLE WATER CONTENT AND 0 PPM DISCRETE WATER CONTENT. LABORATORY CHECKS OF THE RIGHT AND LEFT FUEL STRAINER-FLOWMETER ASSEMBLIES SHOW NO ENTRAPPED WATER. THE PILOTS COMMENTS REVEAL THAT THE FUEL SYSTEM OPERATED NORMALLY DURING THE FLIGHT. NO FUEL SYSTEM ICING OR MALFUNCTION IS SUSPECTED

Approved For Release 2000/05/05 : CIA-RDP71B00590R000200030010-1

~~SECRET~~



25X1A

~~SECRET~~

9766 (IN 78674)

PAGE THREE

AS A CONTRIBUTING FACTOR IN THIS ACCIDENT.

F. ELECTRICAL AND INSTRUMENTS: BASED UPON THE PILOT'S REPORT OF THE COCKPIT CONDITION PRIOR TO BAILOUT, NO BASIC ELECTRICAL SYSTEM MALFUNCTION IS SUSPECTED. A RECOVERED SECTION OF THE PITOT PROBE INDICATES THAT THE HEATER WAS PROBABLY OPERATING TO POINT OF IMPACT. WEATHER PROFILE FOR THE FLIGHT DOES NOT INDICATE THAT AN ICING CONDITION WAS PREVALENT AT THE TIME. THE INSTRUMENTS WERE LOCATED IN THE DEBRIS; THE FUEL FLOWMETERS AND ATTITUDE INDICATORS ARE BEING FURTHER EVALUATED. THE INERTIAL NAVIGATION SYSTEM READ 308 KNOTS GROUND SPEED AND 216 N. MILES TO GO. BECAUSE OF THE PILOT'S REPORT THAT THE TDI READ 1.05 MACH, AND INTENSIVE ELECTRICAL AND PITOT-STATIC STUDY HAS BEEN MADE TO DETERMINE HOW SUCH A MALFUNCTION COULD HAVE OCCURRED. NO PITOT STATIC MALFUNCTION CAN BE DEvised TO PRODUCE THE READINGS OBSERVED BY THE PILOT.

G. POWER PLANT COMMITTEE:

- (1) GATHERING COMPRESSOR DISCS TO ELIMINATE DISC FAILURE AS CAUSE. (PRECAUTIONARY)
- (2) CUTTING INTO ENGINES TO EXAMINE BEARINGS. BEARINGS SEEN SO FAR SHOW NO DISTRESS.
- (3) BLUE-WHITE DEPOSITS NOTED ON LH ENGINE A/B NOZZLE SEGMENTS DETERMINED TO BE EASE-OFF 990 (A DRY LUBRICANT).
- (4) FIRST REPORT FROM COMPONENT TEARDOWN INSPECTION AT

UAD:

- (A) ONE FUEL CONTROL POWER LEVER AT 85 DEGREES, THE OTHER AT 45 DEGREES.

Approved For Release 2000/05/05 : CIA-RDP71B00590R000200030010-1

~~SECRET~~



~~SECRET~~

25X1A

9766 (IN 78674)

PAGE FOUR

(B) BOTH FUEL PUMP SHAFTS SHEARED INDICATING ENGINES ROTATING AT IMPACT.

(C) FUEL SAMPLE ANALYZED - CHECKS OK.

H. MAINTENANCE AND RECORDS: REVIEW OF RECORDS TO DATE REVEALS NOTHING THAT COULD BE CONTRIBUTING FACTOR WITH EXCEPTION OF REPLACEMENT OF AN AMPLIFIER IN AIR DATA COMPUTER PRIOR TO FLIGHT NUMBER 79. DETAILED FINDINGS OF THIS SPECIFIC INVESTIGATION WILL BE REPORTED IN INSTRUMENT AND ELECTRICAL GROUP REPORT.

2. COORDINATING GROUP REVIEWING TECHNICAL GROUP REPORTS AT PRESENT. WILL CONTINUE THROUGH TONIGHT 4 JUN 63 IN AN EFFORT TO ARRIVE AT MEANINGFUL FINDINGS AS EARLY AS POSSIBLE.

END OF MESSAGE

~~SECRET~~



328

Approved For Release 2000/05/05 : CIA-RDP71B00500R000200030009-3

CLASSIFIED MESSAGE

DATE 0131Z 07 JUN 63

~~SECRET~~

1	4
2	5
3	6

TO DIRECTOR
 FROM [REDACTED] 25X1A
 ACTION OSA (1-15)
 INFO : S/C (16)

123 Cross File

PRIORITY

TOR 0256Z 07 JUN 63

IN 78931

25X1A
 25X1A
 25X1A

TO PRITY [REDACTED] INFO [REDACTED] CITE [REDACTED] 9797

OX CART

NO NIGHT ACTION

SUBJECT IS PROGRESS REPORT ON ACCIDENT INVESTIGATION.

1. BOARD HAS REVIEWED AND APPROVED REPORTS FROM FOLLOWING GROUPS:

A. STRUCTURES, EXPLOSION, FIRE: GROUP CONCLUDED INFLIGHT FIRE AND STRUCTURAL FAILURE DID NOT OCCUR.

B. FLIGHT CONTROLS AND HYDRAULICS: GROUP CONCLUDED FLIGHT CONTROLS AND HYDRAULIC SYSTEMS WERE OPERABLE UP TO TIME OF IMPACT AND WERE NOT A CONTRIBUTING FACTOR IN ACCIDENT.

C. OXYGEN, PRESSURIZATION: GROUP CONCLUDES THESE SYSTEMS WERE OPERABLE UP TO THE TIME OF EJECTION AND WERE NOT A FACTOR IN ACCIDENT.

D. FUEL SYSTEMS: GROUP CONCLUDED FUEL SYSTEM ICING DID NOT OCCUR, FUEL USED WAS WITHIN SPECIFICATION LIMITS AND THAT THE FUEL SYSTEM OPERATED NORMALLY DURING FLIGHT AND WAS NOT A FACTOR IN THIS ACCIDENT.

~~SECRET~~

GROUP 1 Excluded from automatic downgrading and declassification

Approved For Release 2000/05/05 : CIA-RDP71B00500R000200030009-3



6

~~SECRET~~

25X1A

██████████ 9797 (IN 78931)

PAGE TWO

E. POWER PLANT: GROUP HAS COMPLETED TEAR DOWN OF ENGINES AND NO MECHANICAL FAILURE WAS FOUND. RIGHT ENGINE WHICH SHOWED LOW RPM AT IMPACT FLAMED OUT AT LEAST 45 SECONDS BEFORE IMPACT DUE TO EITHER FUEL FLOW OR AIR FLOW DISRUPTION AFTER AIRCRAFT STALLED. INLET SPIKES WERE FOUND IN EXTENDED AND LOCKED POSITION. BLEED DOORS WERE IN CLOSED POSITION.

2. OPERATIONS, WITNESS AND MEDICAL GROUP REPORT HAS RECEIVED INITIAL REVIEW BY BOARD AND REQUESTS FOR CLARIFICATION OF SOME POINTS WAS MADE. GROUP IS CURRENTLY REWRITING REPORT WHICH SHOULD BE AVAILABLE BY EVENING 6 JUN FOR RECONSIDERATION OF BOARD.

3. ELECTRICAL AND INSTRUMENTATION:

A. IT HAS BEEN DETERMINED THRU BENCH CHECK HERE THAT A BLOCKAGE OF THE PITOT LINE FEEDING THE ADC WILL CAUSE THE MACH AND KEAS INDICATION ON THE TDI TO REMAIN CONSTANT AS LONG AS ALTITUDE IS HELD CONSTANT.

B. IF THE PITOT SYSTEM IS BLOCKED AS ABOVE AND A CLIMB IS INITIATED AS DESCRIBED BY ██████████ TO 38M THE ALTITUDE WOULD READ CORRECT AND THE MACH AND KEAS WOULD ERRONEOUSLY READ 1.05 AND 310.

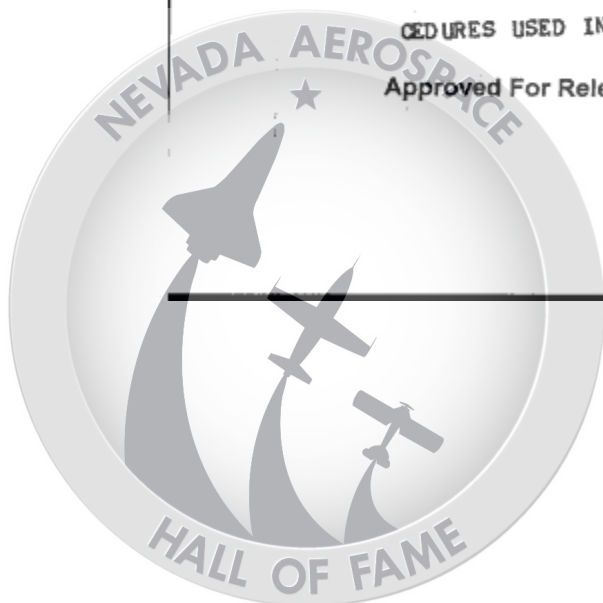
C. THE BLOCKAGE MIGHT HAVE BEEN DUE TO PITOT HEAT NOT TURNED, OR MALFUNCTIONED SWITCH, OR PERHAPS ENTRAPPED MOISTURE.

D. EXCEPT FOR PITOT AND ADC, NO OTHER SUSPECT AREAS IN ELECTRICAL OR INSTRUMENT SYSTEMS AT THIS TIME.

4. MAINTENANCE AND RECORDS GROUP IS STILL INVESTIGATING PROCEDURES USED IN REPLACEMENT OF AIR DATA COMPUTER AMPLIFIER.

25X1A

~~SECRET~~



25X1A

~~SECRET~~

██████████ 9797 (IN 78931)

PAGE THREE

5. INTERIM CONCLUSION: A BLOCKAGE OF THE L.H. PITOT SYSTEM
COULD HAVE CAUSED THE ERRONEOUS READINGS, M-H IS STILL INVESTI-
GATING POSSIBILITY OF ERRONEOUS READINGS DUE TO ADC INTERNAL
MALFUNCTION

25X1A

6. RECOMMENDATION: ██████████ SHOULD PROVIDE HEAT FOR THE
APPROXIMATELY 10 FEET OF PITOT TUBING TO THE ADC ON AIRCRAFT 121,
122, AND 124. AIRCRAFT 125 AND UP HAS HEATED NOSE WHICH NEGATES
REQUIREMENT. ALSO NOTE THAT AIRPLANE 124 PITOT AND STATIC DRAINS
CHECKED AND NO ENTRAPPED MOISTURE FOUND.

7. NO FURTHER PROGRESS REPORTS ARE ANTICIPATED UNTIL
PSYCHOLOGICAL TESTING OF PILOT IS COMPLETED.

END OF MESSAGE

~~SECRET~~



Title:	MEETING WITH THE PRESIDENT, SECRETARY RUSK, SECRETARY MCNAMARA, MR. BUNDY AND D
Abstract:	RE: SURFACING THE OXCART
Pages:	0003
Pub Date:	11/29/1963
Release Date:	7/28/1999
Keywords:	DCI PRESIDENT MEETING BUNDY MR. MCNAMARA SECRETARY RUSK SECRETARY OVERHEAD RECONNAISSANCE OXCART PROGRAM A-12 AIRCRAFT
Case Number:	EO-1995-00056
Copyright:	0
Release Decision:	RIPPUB
Classification:	U



SAC/...

99-27
3



29 November 1963

MEMORANDUM FOR THE RECORD

SUBJECT: Meeting with the President, Secretary Rusk, Secretary McNamara, Mr. Bundy and DCI

RE : Surfacing the OXCART

1.5(c)
3.4(b)(1)

I opened the meeting by advising the President that the OXCART program started as a ~~future~~ development of a Mach 3 plus reconnaissance plane which could fly any place in the world with aerial refueling ~~...~~ The original program called for ten A-12 reconnaissance planes, all of which ~~were~~ now in being and one lost in a crash.

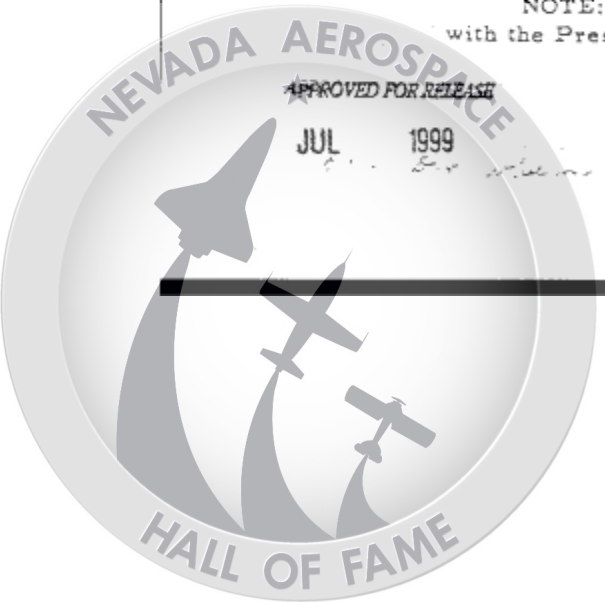
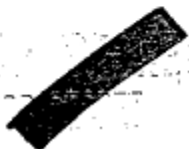
In addition the Air Force were procuring through CIA 5 reconnaissance versions, 3 long-range interceptors which involved a modification (2-seater versus 1-seater), and a total of 31 reconnaissance bombers.

I stated two of the interceptors were operational, a third would be operational shortly and three of the Air Force reconnaissance planes would be delivered shortly. Then there would be a hiatus of several months because two Air Force reconnaissance planes were modified for a special purpose (details not discussed) and the 31 reconnaissance bomber versions involved substantial modification.

The development and the CIA and Air Force reconnaissance planes (15 in number) would cost about \$700 million, of which about \$400 million have now been spent and I had been advised by Secretary McNamara that the entire program of 49 aircraft would cost about \$2 billion.

I pointed out to the President and radar cross-sections features of the plane through which we hoped to make the plane "invisible" to Soviet radar. This has been successful inasmuch as the radar cross-section was in the order of 1/1000 of normal (such as a B-52), but that we also knew of advances in the Soviet radar capability and therefore felt that this plane could probably be detected but we had not concluded as yet that the Soviet SAMS could actually intercept the plane.

NOTE: In a preliminary discussion prior to meeting with the President, McNamara stated that the A-12 could be



~~SECRET~~

detected by the ChiCom SAM radars. I questioned whether this was true, stating I had been informed that the early warning Fan Song radar would have to make the initial detection and then alert the SAM site radar so that they could pick up the plane as it approached. I would like to know what is correct in this regard.

I then stated that the question of surfacing was raised for three reasons:

1. Crash of a plane might bring public notice.
2. Visibility of the program as flying increased and the military versions came into being.
3. Concern that technology developed would give Lockheed and Pratt and Whitney a special position on the SST which would be unfair to other contractors.

I recommended that:

1. DoD and CIA agree on a statement that would be valid to cover:
 - a. Leaks
 - b. A crash
 - c. An executive decision to surface
2. That we not surface for the foreseeable future as doing so was not strictly necessary and would expose an intelligence resource and had some political implications.
3. I arranged to brief selected individuals of companies actually active in the SST program so that they will not be in a disadvantageous position.

The President then requested Secretary Rusk's views, who responded that there was no foreign policy problem but that he felt that if we were to surface, advance information of 2 or 3 days should be given to certain foreign countries such as England, Germany, France, Japan, Australia, etc. In balance Rusk thought it better to make an advance release as a direct policy decision rather than be forced to make an announcement because of a crash or a leak.



1.5(c)
3.4(b)(1)

The President requested McNamara's views, who strongly urged that we surface in the immediate future. He stated he could not see how the reconnaissance capability of CIA would be impaired as we would maintain our fleet of planes and our operations intact [REDACTED]. He noted that increased flying, more planes, a higher rate of expenditure (and he repeated the \$2 billion figure of which about \$400 million is spent), all made it virtually impossible to maintain the same secrecy in the future that we have maintained in the past. Moreover, if he could present the bomber version to Congress, he could eliminate a great deal of criticism, could cut out at least one B-70, saving at least \$75 million, and the technology could be spread among the hundreds of engineers and scientists involved in the SST.

1.5(c)
3.4(b)(1)

The President then decided and ordered that:

- a. We prepare a surfacing paper.
- b. Get as many planes produced [REDACTED] as quickly as possible.
- c. Hold up the surfacing as long as possible, perhaps into the Spring.
- d. Review the subject again at the end of January or in early February for further policy consideration, and
- e. He personally will discuss with Halaby.

All agreed with the decisions and Mr. Bundy undertook to reconcile the differing views between CIA and DoD on the surfacing paper. I then gave Mr. Bundy copies of our mark-up of the DoD paper and also a copy of Dr. Wheelon's paper.

NOTE: Bundy has arranged for Dr. Spurgeon Keeny to serve with him on technical matters on a part-time basis and it is Keeny who is working directly with Bundy on this paper

JAM/rmf



Title:	MEETING WITH THE PRESIDENT, SECRETARY RUSK, SECRETARY MCNAMARA, MR. BUNDY AND D
Abstract:	
Pages:	0003
Pub Date:	11/29/1963
Release Date:	10/10/2002
Keywords:	MCCONE JOHN OXCART RECONNAISSANCE PLANES SAM RADARS
Case Number:	EO-2002-00022
Copyright:	0
Release Decision:	RIPPUB
Classification:	U



NLJ.045.001.001/3

DOC 1/4/68

APPROVED FOR RELEASE
DATE: OCT 2002

29 November 1963

MEMORANDUM FOR THE RECORD

SUBJECT: Meeting with the President, Secretary Rusk, Secretary
McNamara, Mr. Bundy and DCI

RE : Surfacing the OXCART

EC 12958 3.4(b)(1) (C) I opened the meeting by advising the President that the OXCART program started as a further-development of a Mach 3 plus reconnaissance plane which could fly any place in the world with aerial refueling. The original program called for ten A-12 reconnaissance planes, all of which were now in being and one lost in a crash.

In addition the Air Force were procuring through CIA 5 reconnaissance versions, 3 long-range interceptors which involved a modification (2-seater versus 1-seater), and a total of 31 reconnaissance bombers.

I stated two of the interceptors were operational, a third would be operational shortly and three of the Air Force reconnaissance planes would be delivered shortly. Then there would be a hiatus of several months because two Air Force reconnaissance planes were modified for a special purpose (details not discussed) and the 31 reconnaissance bomber versions involved substantial modification.

The development and the CIA and Air Force reconnaissance planes (15 in number) would cost about \$700 million, of which about \$400 million have now been spent and I had been advised by Secretary McNamara that the entire program of 49 aircraft would cost about \$2 billion.

I pointed out to the President and radar cross-sections features of the plane through which we hoped to make the plane "invisible" to Soviet radar. This has been successful inasmuch as the radar cross-section was in the order of 1/1000 of normal (such as a B-52), but that we also knew of advances in the Soviet radar capability and therefore felt that this plane could probably be detected but we had not concluded as yet that the Soviet SAMS could actually intercept the plane.

NOTE: In a preliminary discussion prior to meeting with the President, McNamara stated that the A-12 could be

~~TOP SECRET~~



detected by the ChiCom SAM radars. I questioned whether this was true, stating I had been informed that the early warning Fan Song radar would have to make the initial detection and then alert the SAM site radar so that they could pick up the plane as it approached. I would like to know what is correct in this regard.

I then stated that the question of surfacing was raised for three reasons:

1. Crash of a plane might bring public notice.
2. Visibility of the program as flying increased and the military versions came into being.
3. Concern that technology developed would give Lockheed and Pratt and Whitney a special position on the SST which would be unfair to other contractors.

I recommended that:

1. DoD and CIA agree on a statement that would be valid to cover:
 - a. Leaks
 - b. A crash
 - c. An executive decision to surface
2. That we not surface for the foreseeable future as doing so was not strictly necessary and would expose an intelligence resource and had some political implications.
3. I arranged to brief selected individuals of companies actually active in the SST program so that they will not be in a disadvantageous position.

The President then requested Secretary Rusk's views, who responded that there was no foreign policy problem but that he felt that if we were to surface, advance information of 2 or 3 days should be given to certain foreign countries such as England, Germany, France, Japan, Australia, etc. In balance Rusk thought it better to make an advance release as a direct policy decision rather than be forced to make an announcement because of a crash or a leak.



EO 12958 3.4(b) (1)
(C)

The President requested McNamara's views, who strongly urged that we surface in the immediate future. He stated he could not see how the reconnaissance capability of CIA would be impaired as we would maintain our fleet of planes and our operations intact

[redacted] He noted that increased flying, more planes, a higher rate of expenditure (and he repeated the \$2 billion figure of which about \$400 million is spent), all made it virtually impossible to maintain the same secrecy in the future that we have maintained in the past. Moreover, if he could present the bomber version to Congress, he could eliminate a great deal of criticism, could cut out at least one B-70, saving at least \$75 million, and the technology could be spread among the hundreds of engineers and scientists involved in the SST.

The President then decided and ordered that:

- a. We prepare a surfacing paper.
- b. Get as many planes produced and out at the site as quickly as possible.
- c. Hold up the surfacing as long as possible, perhaps into the Spring.
- d. Review the subject again at the end of January or in early February for further policy consideration, and
- e. He personally will discuss with Halaby.

All agreed with the decisions and Mr. Bundy undertook to reconcile the differing views between CIA and DoD on the surfacing paper. I then gave Mr. Bundy copies of our mark-up of the DoD paper and also a copy of Dr. Wheelon's paper.

NOTE: Bundy has arranged for Dr. Spurgeon Keeny to serve with him on technical matters on a part-time basis and it is Keeny who is working directly with Bundy on this paper

JAM/mfb



Title:	(EST PUB DATE) CONTINGENCY PLANNING FOR PROJECT OXCART
Abstract:	
Pages:	0001
Pub Date:	1/1/1964
Release Date:	12/30/1998
Keywords:	AIR FORCE AIRCRAFT OXCART NRO FLIGHT TESTING OSA PROJECT KEDLOCK
Case Number:	F-1997-01869
Copyright:	0
Release Decision:	RIPPUB
Classification:	U





CENTRAL INTELLIGENCE AGENCY
WASHINGTON 25, D. C.

OFFICE OF DEPUTY DIRECTOR OF CENTRAL INTELLIGENCE

[Redacted]
See A Copy

MEMORANDUM FOR: Dr. Brockway McMillan
Director, National Reconnaissance Office

SUBJECT : Contingency Planning for Project OXCART

1. I am informed that the Director, Program D, is moving ahead to formulate plans calling for the delivery of the first Air Force OXCART version to Edwards Air Force Base, California, where it and successive prototypes are planned for initial flight testing. Were this course of action to be continued without suitable contingency planning, we would find ourselves in the late spring of 1964 with no suitable alternative to what amounts to de facto surfacing, when the first Air Force aircraft shows up at Edwards.

2. Accordingly, I request that you instruct the Director, Program D, to consult and confer with the Director, Program B, toward developing in the next few weeks a contingency plan which would permit the first prototype of the Air Force version of OXCART to be accommodated [redacted] where OXCART flight testing is currently in process. I understand that meaningful preliminary flight testing of the USAF aircraft can be conducted at [redacted] during the period from roughly 1 August through 31 December 1964. This time interval may be critical when viewed against the prospective operational readiness date of OXCART, now estimated for mid-summer of 1964.

3. I have directed [redacted] as Director of OSA, to ensure that appropriate facilities of the Agency are made available for the development of this plan, and to keep the Director periodically informed.

Marshall S. Carter
Marshall S. Carter
Lieutenant General, USA
Deputy Director



Title:	(EST PUB DATE) SPEED TRIALS YF-12A
Abstract:	
Pages:	0004
Pub Date:	1/1/1964
Release Date:	8/8/2000
Keywords:	AIRCRAFT FLIGHT TESTING YF-12A OXCART PROGRAM A-12 SPEED TRIALS
Case Number:	F-1991-02144
Copyright:	0
Release Decision:	RIPPUB
Classification:	U



~~TOP SECRET~~

SPEED TRIALS YF-12A

General Stewart

1. ASSUMPTIONS:

a. Since the President has publicly announced the DOD has been directed to break the speed record, every reasonable effort will be made in CY 1964 to do so. Further, it has been inferred that the speed would be in the vicinity of 2,000 mph.

b. An interim operational capability with the A-12 is desired by not later than mid-November.

2. INFLUENCING FACTORS:

a. Much remains to be done in the flight test program. Engine control above Mach 2.4-2.6 is the critical item (control of inlet shock position using either the latest Ham Standard or LAC equipment is far from a routine operation).

b. All flight test above Mach 2.95 has been done in one aircraft (# 121).

c. The best equipped and most capable aircraft in the overall fleet are #'s 129 and 121; these are the primary contractor test aircraft. Conversely, the least capable (and lowest priority aircraft) are the YF-12A's which are restricted to Mach 2.6 and are flying with fixed

"spikes."

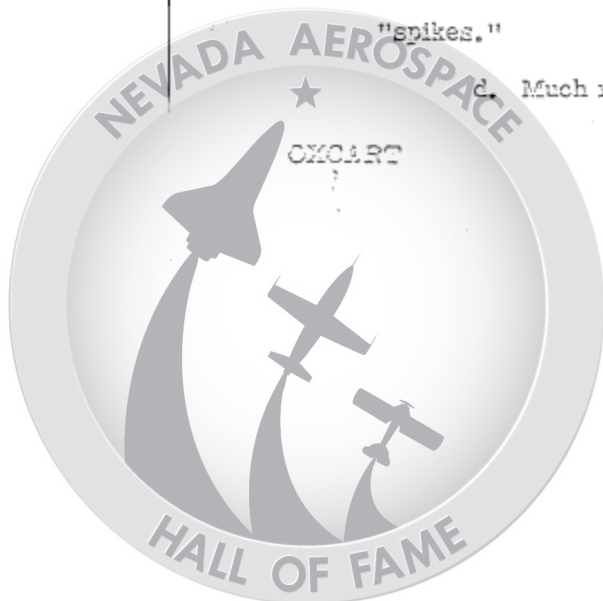
d. Much remains to be done in the operational training program.

b(1) b(3)

RELEASED AUG 2000

~~TOP SECRET~~

2



~~TOP SECRET~~

Although several mission pilots have accumulated considerable hours in the A-12 aircraft, severe operational limitations have been imposed because the R&D program is not yet far enough along on both aircraft and mission sub-systems. No realistic operational training missions have yet been flown.

e. The program currently is hampered by equipment shortages and deficiencies: hydraulic actuators; ^{ORS} "J-model" afterburners; and the latest model inlet controls. Of the three, all are in short supply, ~~but the afterburners are controlling.~~ See attachment I for "get-well" schedule.

f. The probability of setting a new speed record on the first try is by no means a 90 percent certainty--even if the aircraft operates perfectly--since a high degree of flying precision is required at Mach 3 speeds and 80,000 feet altitudes. The possibility of missing the "gates" and "corridors" is significant. The closed-course speed run (if a speed of 1800-2000 mph is desired) is a more difficult operation than the straight-line run.

g. The first R-12 (in major sub-assemblies) will be delivered to Palmdale in late October.

3. POSSIBLE COURSES OF ACTION:

a. As a cover, redesignate # 121 or # 129 as the XSR-71, "borrow" a tail number from the R-12 "black", ferry to Edwards AFB and set the speed run as soon as possible. Practice run ~~could~~ be made in a YF-12A

2

~~TOP SECRET~~



~~TOP SECRET~~

at a lower Mach number. The probability of success is good; however, this would disrupt the flight test program from 2-4 weeks, delay the interim A-12 operational capability by a like period, and offers some security risk to the OXCART Program.

b. Divert hydraulic actuators, "J" engines and afterburners, and inlet controls to a YF-12A aircraft (or two aircraft) and run the speed trials in September. Except for eliminating the security risk, this option has the same disadvantages as 3a above.

c. Same as 3a above, except wait until the first R-12 is delivered to Palmdale. Practice runs would be made in a YF-12A at lower Mach numbers. This possibility lessens the security risk to the OXCART Program and has less impact on the flight test program. Hopefully, it would not delay the attainment of an early interim operational capability with the A-12 aircraft.

d. The contractor believes he could prepare a YF-12A for the speed runs by end-October without disrupting the flight test program or slipping the A-12 interim operational capability. In this option, # 121 or # 129 (designated as the XSR-71) could be used as a back-up and practice runs made in an unmodified YF-12A. If # 121 or # 129 had to be used, there would be a certain amount of security risk to the A-12 Program

~~TOP SECRET~~



~~TOP SECRET~~

and some disruption to the flight test program.

e. Same as 3d above, except not use # 121 or # 129 as a back-up. If only one YF-12 were modified, the chances of success in late October are lessened. It would appear that a good likelihood of slip into November or December would exist.

f. Modify the YF-12A's routinely as scheduled and run the speed trials when available. It would appear that the speed runs would then be made in January or later.

g. Conduct the speed runs using R-12 (SR-71) aircraft. The speed runs, under this option, probably could not be reasonably conducted before the spring of 1965.

4. RECOMMENDED COURSE OF ACTION:

a. Set up a target date of late October. Start preparing one YF-12A (actuators, afterburners, inlet control, etc) for the record attempt without disrupting the flight test program and/or the interim A-12 capability. Conduct practice runs with the Mach-limited YF-12A's in mid-October. At that point in time, if the YF-12A up-dating is behind schedule, the possible use of 121 or 129 (designated as an XSR-71) can be re-evaluated.

~~TOP SECRET~~



Title:	CONTINGENCY PLANNING FOR PROJECT OXCART
Abstract:	
Pages:	0001
Pub Date:	2/5/1964
Release Date:	12/30/1998
Keywords:	PRESIDENT SECRETARY OF STATE OXCART CONTINGENCY PLANNING VEHICLES NRO PROJECT KEDLOCK
Case Number:	F-1997-01869
Copyright:	0
Release Decision:	RIPPUB
Classification:	U





~~TOP SECRET~~
DEPUTY DIRECTOR OF CENTRAL INTELLIGENCE
WASHINGTON 25, D. C.

5 February 1964

MEMORANDUM FOR: Director, NRO

SUBJECT : Contingency Planning for Project
OX CART

1. I am glad to note in your memorandum of January 29 that it appears feasible to hold all OXCART-type vehicles at [REDACTED] at least until January 1965. This will greatly assist in helping to avoid surfacing until an operational capability has been achieved, or until such decision may be taken by the President for other reasons.

2. In this connection, at a meeting held at the White House on November 29, 1963, with the Secretary of State, the Secretary of Defense, the Director of Central Intelligence, and the Special Assistant to the President for National Security Affairs, the President decided not to surface at that time and to review the matter again in late January or early February.

Marshall S. Carter
Marshall S. Carter
Lieutenant General, USA

Copy # *1*
[REDACTED]

~~TOP SECRET~~
[HANDLE VIA [REDACTED] ONLY]

Series *1* Copy # *3*

2



Title:	MEETING WITH THE PRESIDENT - 20 FEBRUARY 1964 - ALONE
Abstract:	
Pages:	0002
Pub Date:	2/20/1964
Release Date:	7/2/2002
Keywords:	MATEOS PRESIDENT JOHNSON PRESIDENT OXCART EISENHOWER GENERAL NOSENKO FRANCO
Case Number:	EO-2002-00023
Copyright:	0
Release Decision:	RIPPUB
Classification:	U



~~SECRET EYES ONLY~~

20 February 1964

MEMORANDUM FOR THE RECORD

SUBJECT: Meeting with the President - 20 February 1964 - Alone

1. I advised the President of my willingness to go with him and to meet early in the day with General Eisenhower if he thought this would be constructive. He said he felt General Eisenhower might feel he was being high-pressured and that he intended merely to advise him of the plan to surface the OXCART and exchange formalities. He would then tell him he was ordering me to go out and brief him in the next week or two and I should make my own arrangements.

2. I told the President we had a very sensitive effective operation working in Mexico City [redacted] which involved telephone surveillance and was being done in a most careful manner [redacted]

EO 12958 3.4(b)(1)-25
EO 12958 3.4(b)(6)-25
(C)

[redacted] Ambassador Mann knew of this from Scott, as did certain selected people in State Department. [redacted] did not know of Mann's knowledge of the operation and looked upon the operation as an [redacted] arrangement between [redacted] and the CIA station. [redacted]

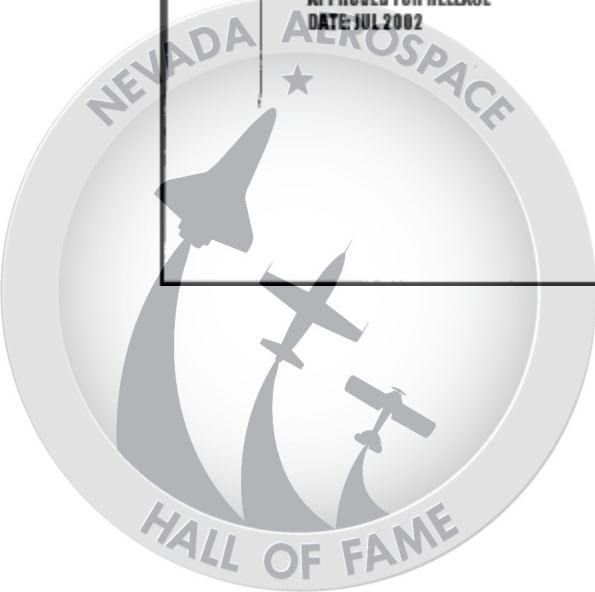
[redacted] I said the President should not mention this but I wanted him to know about it [redacted]

3. I told President Johnson that we continued our interrogation of Nosenko; our counterintelligence people were inclined to feel he was a plant but had not made up their minds. President said he thought he was probably legitimate and would give us some good information. I said I hoped this was true - that we certainly were taking advantage of everything that he did give us; that we were working closely with the FBI, however we could only conclude at the moment that the Soviet's performance and action were so different from any other defector case that our suspicions had been aroused. The President asked to be kept informed.

4. The President then raised the question of Spain, suggesting I might return to Spain to talk again to Franco. He said he was in a very difficult situation because of announcement of the cut-off of aid to Britain, France and Yugoslavia which he did not know about until he read it in the paper, and that he was beside himself because he wanted to give aid of \$31 million to Spain but had the greatest difficulty in the justification.

APPROVED FOR RELEASE
DATE: JUL 2002

~~SECRET EYES ONLY~~



~~SECRET EYES ONLY~~

I told the President it was my impression from information gained from clandestine sources that Franco had made some moves to curtail trade with Cuba after my visit with him but that the Spanish companies were endeavoring to circumvent his orders by various surreptitious methods. The President asked that I study the matter carefully and speak to him about it next week.

EO 12958 3.4(h)(1)-25Yrs
(C)

ACTION: I have asked Mr. O'Ryan to contact and I am asking Mr. Ball to contact Ambassador Woodgrd to determine whether the Spanish had taken any actions which they have announced or might communicate to us which would indicate an intention on their part to curtail or restrict shipping or trade with Cuba.

5. The President then said he wanted to do everything possible to get me out of the cloak and dagger business. That he was tired of a situation that had been built up that every time my name or CIA's name was mentioned, it was associated with a dirty trick. He asked if our economic studies had stood up and I said yes, they had, and that they were reconfirmed and supported by an exhaustive article in TIME Magazine. The President seemed pleased at this, expressed satisfaction in CIA's operations but was most emphatic in his feelings that we should get away from the cloak and dagger image and expressed a determination to bring this about by statements he would make from time to time.

~~SECRET EYES ONLY~~

JAM/mfb



Title:	DISCUSSION WITH THE PRESIDENT AT 1:00 O'CLOCK, FEBRUARY 26TH; NO ONE WAS PRESEN
Abstract:	
Pages:	0004
Pub Date:	2/27/1964
Release Date:	7/2/2002
Keywords:	CUBA SOUTH VIETNAM SOVIETS EISENHOWER SAM SITES SATELLITE PHOTOGRAPHY
Case Number:	EO-2002-00023
Copyright:	0
Release Decision:	RIPPUB
Classification:	U



27 February 1964

MEMORANDUM FOR THE RECORD

SUBJECT: Discussion with the President at 1:00 o'clock, February 26th;
No one was present

1. Briefly discussed the trip to South Vietnam. President indicated he expected that I would be with the McNamara/Taylor group. He did not specifically ask that I go nor did I ask him whether I should. It seemed a foregone conclusion in his mind that I was going and he was looking forward to an objective and independent judgment of the situation in South Vietnam from me.

2. He expects me to brief Eisenhower in the near future. He had so told Eisenhower. He did not wish me to make a special trip for this purpose but suggested that I meet with Eisenhower as soon as convenient. I explained that if McNamara's trip was timed, as I expected it would be, I could leave on Wednesday, March 4th, see Eisenhower for about one day, proceed commercially by plane to Honolulu and join the McNamara party there. The President thought this was a good plan. Otherwise he thought I should brief Eisenhower at the earliest convenient time.

EO 12958 3.4(h)(1)>25Yrs
(C)

3. I told the President we had completed an extended CORONA coverage of the Soviet Union involving the photographing of [redacted] Soviet landmass.

[redacted] This gave me an opportunity to discuss the CORONA J development. I said that the photography had not been completely studied but the evidences were that the Soviets were slowing up or stopping construction of soft ICBM sites and were emphasizing the construction of hard sites.

[redacted] knew that through satellite photography we were learning the exact location of missile sites. He was not relocating them - what he was doing, he was hardening them, and this was costing them an enormous amount of money. The President expressed great interest in the subject of satellite photography and I asked for an hour's time to go over the program, the pictures and other details. He agreed. I suggested perhaps when he was flying some place I go with him and we could spend an hour or so together on this one subject. This he felt might be a good idea.

APPROVED FOR RELEASE
DATE: JUL 2002

NEVADA AEROSPACE



HALL OF FAME

ACTION: Remind me to follow this up and to make arrangements on a Presidential trip in the near future.

4. I then discussed the surfacing of the OXCART and advised him that Chairman Vinson and Senator Russell felt that their Committees should be fully informed by them and they wished to do this in advance of the announcement and also stated that Mr. Cannon wished me to meet with his Subcommittee prior to the announcement and that George Mahon wished to inform his committee prior to the announcement. I recommended that this be done but it be timed so the Committees would be advised practically concurrently with the announcement so that the press would not get the news before the President announced it. I said that if, for instance, he was to make the announcement Saturday morning (which he did not confirm at the time), then all of the Congressional actions should be taken Saturday morning. Thus the Congressmen would know in advance but not so much in advance that the press would get hold of the story. The President was very much against this. He felt that if the announcement was made on Saturday, we could inform the Committees on Monday. I stated that this would cause the Committee Chairmen and the Committees a great deal of trouble. With this Johnson picked up the phone to call Senator Russell; however the call was not returned and I did not get a final decision.

ACTION: Later I mentioned the question to Bundy and he said that he would have to get to the President and get a decision. Until this decision is forthcoming we should take absolutely no action with respect to the Hill. Bundy and I discussed the problem several times during the day, including a brief discussion at Mrs. J. F. Kennedy's residence when the President was there. However, Bundy did not think it appropriate to discuss it with the President on the particular occasion at Mrs. Kennedy's residence. This should be followed up with Bundy today.

EO 12958 3.4(h)(1)-25Yrs
(C)

5. I then referred to the [redacted] This item refers to the withdrawal of the Soviets from Cuba and the turning over of the SAM sites to them. I said there was a high probability that the SAM sites would be placed in the hands of the Cubans who would have absolute control over them. I said that other evidence convinced us there would be a continuing withdrawal of Soviets from Cuba, but not a total withdrawal; however we could not gauge the exact numbers. I said that this, in my opinion, represented probably the next important crisis that we would face because Castro in his rather amicable but long press conference had raised the question of our penetrating illegally Cuban air space. I therefore recommended that this subject be discussed with Secretaries of State and Defense; that they be ordered to prepare contingency plans for such a situation, otherwise we would be confronted with an emergency.



all the lights in town would be on, and our course of action would have to evolve under an atmosphere of emergency. I pressed this point hard. The President asked if I had discussed it with McNamara and Rusk and I told him I had, on many occasions, but they seemed wholly preoccupied with the problem at hand and had never come to grips with this particular hypothetical but possible situation. The President gave me no satisfactory answer as to any action he would take. In fact, he seemed more preoccupied with the withdrawal of Soviets and the "numbers remaining" than he did with the issue I was confronting him with.

6. We were then joined by Secretary Rusk, Harriman, Edgar Kaiser and Mr. Calhoun and engaged in a long discussion on Ghana. Kaiser reported on his conversations with Nkrumah and his absolute and positive insistence that Nkrumah stop the anti-American actions in his country or else he, Kaiser, could not proceed with the work. Furthermore, under the climate that Nkrumah had developed Kaiser could not raise a single cent toward additional investments in Ghana. Nkrumah seemed to agree and said he was writing President Johnson.

EO 12958 3.4(h)(1)-28/75
(C)

[REDACTED]

The President asked Kaiser what he wished to do. Kaiser stated that he had a contract that had not been broken by Ghana despite the exasperating situation and that he intended to fulfill his contract. He reviewed the situation about as follows: Volta Dam will cost about \$200 million of which Ghana is putting up half and the other half is being put up by AID, the World Bank, the British, and the Export-Import Bank in varying amounts and for differing components or parts of the project. The aluminum plant will cost about \$150 million, about \$100 million has been put up by the Export-Import Bank and about \$50 million by the Kaiser-Reynolds Syndicate (Kaiser, 90% - Reynolds, 10%) but all of this is guaranteed by the United States Government. The entire \$350 million in the form of loans, there are no grants made. The power that Kaiser will take, representing half of the power generated at the dam, will pay for the entire project in 30 years. Kaiser stated that he could not forecast the permanence of his position in the project. It was entirely possible that Nkrumah would take it over. This was a risk and represented a very serious problem to him because he was proceeding with manufacturing outlets in Europe to utilize the raw aluminum produced. Despite this risk he was going forward. The President was noncommittal.

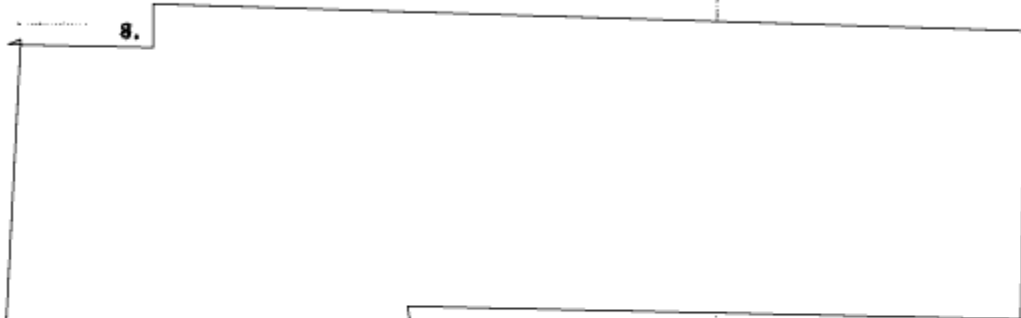
7. Later Governor Harriman stated he wanted to get together with me to reach a conclusion on our policy concerning the Volta Project. He was in favor of proceeding -- there were many who wished to cut and run. He sensed that I would favor staying with the project. What he was seeking was a partner to support his position.

NEVADA AIRSPACE

HALL OF FAME

EO 12958 3.4(b)(1)-25Yrs
(C)

8.



EO 12958 3.4(b)(1)-25Yrs
(C)



JAM/tape



Title:	MEMORANDUM OF DISCUSSIONS WITH SECRETARY VANCE
Abstract:	
Pages:	0002
Pub Date:	8/17/1964
Release Date:	8/8/2000
Keywords:	CUBA READINESS TEST FLIGHTS OVERFLY A-12 AIRCRAFT JOHNSON KELLY VANCE SECRETARY SPEED TEST
Case Number:	F-1991-02144
Copyright:	0
Release Decision:	RIPPUB
Classification:	U



~~TOP SECRET~~

17 August 1964

MEMORANDUM FOR THE RECORD

SUBJECT: Memorandum of Discussions with Secretary Vance

Following the meeting with Kelly Johnson, et al, covered in the attached memorandum, I called Secretary Vance and stated:

1. The operational readiness of four aircraft on November 1st with a capability to overfly Cuba at 2.8 Mach at 80,000 feet was contingent upon placing of work ██████████ on the highest priority. It was, among other things, dependent upon flight testing of 3 aircraft - 121, 122 and 129 - on a maximum frequency basis from August 10th to November 1st, and developing from these test flights the betterments and modifications which must be incorporated in the operational aircraft as part of the operational readiness program.

Moreover, the program called for the equipping of the 4 operational aircraft -- 125, 127, 128 and 132 -- with parts and replacements on a priority basis as they became available and then operating these four planes on check-out tests, simulated runs, etc. in the period prior to November 1st.

The speed test, if attempted, would foreclose the operation of 2 of the 3 test planes for about one month and the effect this would have on the operational readiness date could not be calculated. Furthermore the diversion of parts, etc., to Edwards would reduce the number of operational aircraft from 4 to 2.

It was Mr. Johnson's conclusion that the diversion of component parts and the utilization of experienced personnel in the speed run tests during the latter part of August and early part of September would seriously affect the prospect of meeting the operational readiness date of November 1st and would probably delay this date for at least 30 days and perhaps longer.

NOTE: In this conversation I emphasized to Mr. Vance that I had serious reservations about the November 1st date and felt it could only be met if the A-12 program retained the highest priority.

~~TOP SECRET~~

RELEASED AUG 20 1964

b(1) b(3)

5



2. With respect to the speed run, I pointed out that the AF-12 aircraft were last in line from the standpoint of being equipped for maximum speed because, with respect to those planes, armament was given a higher priority and they were being flown to test the armament features rather than to attain speed. Therefore we were in effect taking some of the least well-equipped planes and trying to put them ahead on a crash program in order to run the speed test. I said this feature alone made the success of the speed test highly questionable in my mind.

In view of the above it was my specific recommendation that the speed test be abandoned and I wished him to confer with Secretary McNamara prior to McNamara's departure on his vacation so that a final decision could be reached by Vance and me upon my arrival in Washington this evening.

After my conversation, General Stewart stated that he concurred in my recommendation and hoped they would be accepted. Col. Ledford also concurred and Kelley Johnson concurred most emphatically. None of the 3 heard the responses from Secretary Vance, but all could hear my recommendations and the reasons as expressed above.

Upon arrival in Washington I called Vance and he reported that he and McNamara had agreed with my recommendation that the speed test be abandoned and that the work on the A-12 program be given highest priority. Vance then asked that we explore the possibility of running the speed test at an early date with an A-12 plane. I said that this had been discussed - it involved some questions of disclosure, but I would examine the question and discuss the matter further with him.

JAM/mfb



Title:	DISCUSSION AT LOCKHEED. IN ATTENDANCE: KELLY JOHNSON, MCCONE, GENERAL STEWART A
Abstract:	
Pages:	0004
Pub Date:	8/18/1964
Release Date:	8/8/2000
Keywords:	MCCONE OXCART PROGRAM JOHNSON KELLY SKYLARK AF-12 LEDFORD COLONEL READINESS PROGRAM STEWART GENERAL
Case Number:	F-1991-02144
Copyright:	0
Release Decision:	RIPPUB
Classification:	U



~~TOP SECRET~~

18 August 1964

MEMORANDUM FOR THE RECORD

SUBJECT: Discussion at Lockheed. In attendance: Kelly Johnson, McCone, General Stewart and Colonel Ledford

1. The purpose of the meeting was to generally review the status of the OXCART program and the effect on desired readiness dates if the speed test with an AF-12 is attempted in September.
2. The attached communication from McCone to Kelly Johnson was used as an agenda for the meeting.
3. Speed Test. Johnson stated on orders received from McMillan on Wednesday, August 12, 37 Lockheed personnel had been transferred ██████████ to Edwards. The engines on plane 121 had been removed and boxed for shipment and loaded on a C-130, but had not been moved. Several valves and other parts for plane 122 were being diverted to Edwards. The order received from McMillan called for placing the speed test on the highest priority, to be accomplished in September. It is recognized that this would delay further flights on 121 and 122 for two to four weeks (probably the latter) -- would limit testing to flights of 129 during September -- and would place two rather than four operational planes in a state of readiness for 1 November.
4. Readiness Program. Prior to the "speed run orders" it was planned to have planes 125, 27, 28 and 132 checked out and tested and in a state of operational readiness at Mach 2.8, altitude 80,000 ft., range 2500 n.m. for a Cuban capability (Operation SKYLARK). The deficiencies were inlet control, engines with the most up-to-date modifications and both of these caused what Johnson described as most conservative estimates. He expected to exceed both the speed and the range mentioned above.
5. Program 2 called for operational readiness of plane 131 at Mach 3.2, 3,000 mile range and 85,000 ft. by January 15. Inlet control and the advance J engine are both critical. 131 is used as a test bed for a variety of ECM developments and for air-borne side-looking radar.

b(1) b(2)

~~TOP SECRET~~

RELEASED AUG 2000

①

NEVADA AEROSPACE

HALL OF FAME

~~TOP SECRET~~

6. Program 3 - designed for Mach 3.2 at full range, certain modifications and the introduction of Tacan equipment to facilitate contact for refueling introduces delays in this program and if all modifications are incorporated, then the readiness date of the 8 planes in the operational program will be between May and December 1965.

7. In this connection there are 11 planes in the A-12 program. Three of them, 121, 122 and 129 are considered test beds, the remaining 8 operational aircraft.

8. The Range Problem. The Hamilton inlet control on 121 and 122 give a high fuel consumption and elapse time in going through the sound barrier -- 1.9 Mach to 1.2 Mach. Plane 129 with Lockheed control is somewhat better. However, this problem is not answered and therefore the range is affected. It is expected that the J-type engine with after burners and with the Lockheed control will improve the situation but not correct it. (Currently the area between actual performance and wind tunnel test is about 20%.) (Convair engineers are extremely worried over the difference between actual performance and the wind tunnel tests which vary as much as 100%.)

9. The specifications call for a range of 4,044 miles. It is hoped that 129 will test out at 3,320 miles. Changes in specifications including the amount of reserve fuel account for 450 n. m. of the difference. Increased weight of engine, acceleration through the sound barrier and other operational difficulties account for 390 n. m.

10. Testing of quadruple range of 3,300 n. m. will be made in the near future with plane 129. This plan flew on August 17.

11. Cameras seem to be O. K. However, the effect of high temperatures on the windows has as yet not been tested.

12. Most specific with respect to attempting speed tests, the following observations were made:

a. Plane 121 is considered the engine test bed and cannot be equipped with a suitable engine for testing purposes for 3 to 4 weeks. Flights during this period with substitute engines would contribute little.

b. Plane 122 is used to test controls and two to three weeks more delay is expected in receiving equipment to replace that which has been cannibalized.

- 2 -

~~TOP SECRET~~



c. Plane 129 was ready to fly on August 17.

13. In summary the test program called for the flying of 3 test beds from August 10 until November 1. The speed test program would remove 2 planes (121 and 122) from the test program until September 15th at the earliest.

14. It was planned to bring 4 operational planes, 125, 27, 28, and 32 up to operational readiness during October and to check them out thoroughly to meet the November 5th deadline. The speed test program would reduce this to 2 airplanes and since they would be flown extensively on simulated missions and to gain experience, fear was expressed that one or both of them might encounter mechanical difficulties, thus removing the entire capability. Furthermore, the decreased testing program might not bring forth all of the bugs and problems early enough to insure accomplishment of necessary modifications and retrofits to operational plans. Hence, it was Kelly Johnson's opinion that the speed test program would delay the operational readiness by at least a month.

15. McCone agrees with this, however, I question and am deeply concerned over the possibility of attaining the operational readiness by November 1. Certainly this cannot be done unless:

a. Lockheed be instructed to place the operational readiness of the A-12 on the highest priority and that no one interfere. NRO must understand this and SAC, who are now becoming more active with their RS-71 program must recognize this priority.

b. NRO, CIA and the operational people must recognize that we seek in Project SKYLARK an operational readiness against Cuba and therefore we must be constrained to introduce only such modifications, ECM equipment and other gadgets as are required for this mission. (This should include the Bird Watcher.)

16. The pilot training program would be upset by the speed tests, but this deficiency could probably be overcome.

17. The time when the speed test could be conducted was discussed and it became apparent that the whole idea was premature. The 3 AF-12's at Edwards had not been brought up-to-date with modifications and betterments indicated as necessary to meet the 3.2 Mach condition because emphasis had been placed on armament, missile adaption, etc.



Hence these planes were behind the A-12's. What is involved is taking the most deficient plans and pushing them ahead on a crash basis. This Kelly Johnson feels unwise, although he noted that some but not all modifications had been made on all planes during the recent weeks when the planes had been grounded.

18. In conclusion the following summarizes the answers to the questions in my communication to Mr. Johnson:

a. Johnson feels that 4 operational vehicles will be ready on 1 November to operate against Cuba at 2.8 Mach and 80,000 ft. McCone has reservations and believes this can only be accomplished on the conditions outlined above.

b. Johnson feels the feasibility of a speed run with the AF-12 is questionable and recommends against it for the reasons mentioned.

c. The interceptor aircraft at Edwards had been concentrating on armament and not on speed. The program is going satisfactorily but is not foundation for a speed test.

d. Johnson expressed concern over the Air Force reconnaissance program. He said Lockheed was scheduled to produce one plane a month and funding was such that they were required to order components and parts from their subcontractors a few at a time. This produced gaps of several months in the subcontractors production effort. Johnson further stated that a large number of Air Force officers are coming in for orientation and undoubtedly would assume supervision.

19. The ^{Tag Board} test bed program was reviewed briefly and will be the subject of a report.

20. With respect to the Lockheed organization, Johnson claims he has the "bases covered." I was of the impression that the organization is overloaded and believe it most important to get the A-12 fully checked out and off of his mind so as to turn him loose to work on the AF-12 and the RS-71.

JAM:mcm

~~TOP SECRET~~



Title:	EFFECT OF USING OXCART 121 FOR SPEED RECORD ATTEMPT
Abstract:	
Pages:	0002
Pub Date:	8/20/1964
Release Date:	8/8/2000
Keywords:	PARIS OXCART SKYLARK FAI NNA RECONNAISSANCE CAPABILITY SPEED RECORD
Case Number:	F-1991-02144
Copyright:	0
Release Decision:	RIPPUB
Classification:	U



Dutton up today -
kill whole project

20 AUG 1964

1 call to DCI

MEMORANDUM FOR: Director of Central Intelligence
SUBJECT: Effect of Using OXCART 121 for Speed Record Attempt

1. You have asked DD/S&T to examine the possibility of using OXCART No. 121 to establish a world's speed record, in lieu of the recently cancelled use of the interceptor version, and to estimate the impact of such a utilization on our priority program to establish an early operational capability at Mach 2.8 (SKYLARK) with the basic OXCART reconnaissance version. Our conclusion is that it is not wise to use 121 for this purpose at this time for the following reasons.

2. We reckon that the speed trial would take 121 out of our flight test program for three to four weeks. This represents 10 to 12 lost flight tests which are valuable in an ancillary reliability and repeatability support role in qualifying the operational vehicles for sustained Mach 2.8 flight and the eventual 3.2 capability.

3. Because No. 121 is a unique aircraft, in terms of its test instrumentation, we are frankly apprehensive about committing it to a flying program which is not essential to establishing the over-all OXCART capability. Although we cannot say that flying for a speed trial is riskier than making the requisite flight tests for OXCART, we would be liable to severe criticism if 121 were to be lost while attempting such a record at a time when it was uniquely important to our major goal.

4. We have reluctantly gone along with the previous A-11 and SR-21 surfacing in the hope that the public story would start with these two seater aircraft, leaving us the

Copy 2

[Redacted]

b (1) b (3)

TOP SECRET

RELEASED AUG

2000
47



~~TOP SECRET~~

187-64
Page 2

possibility of keeping the 10 single place planes [redacted]
[redacted] If we now enter one of the genuine OXCART
aircraft in a speed run, it will be easily recognized as
distinct (see below) and as an additional aircraft to
three now at Edwards. The whole question of its source
and companions will then arise, stripping off both our
residual security and labeling the DOD claim of a new
aircraft development for what it really is.

5. There are firm requirements for certifying a
world speed record, which will guarantee the disclosure
of the OXCART technical features in a way that we find
unacceptable. These trials are conducted by the
Federation Aeronautique Internationale (FAI) in Paris,
working through the U. S. National Aeronautic Association
(NAA). However, it is possible that foreign nationals
could and would insist on taking part in such a test.
Specifically, the FAI/NAA representatives must:

- a. Inspect the aircraft on behalf of the
FAI and report to them.
- b. Certify the takeoff and landing.
- c. Validate the photo panel and/or barograph
installation used for test purposes.
- d. Certify positive radar and optical tracking
during the test runs.

All in all, we will retain very little security for OXCART
as an operational vehicle if we sign up for this event.

6. If we are to establish an OXCART operational
reconnaissance capability with as much security as is
left to us now as soon as possible, we must oppose the
use of aircraft 121 for this purpose.

(Signed) Jack C. Ledford

Approved: *Albert D. Wheelon*

ALBERT D. WHEELON, DD/S&T

cc: DDCI

JACK C. LEDFORD
Colonel USAF
Assistant Director
(Special Activities)

~~TOP SECRET~~



Title:	SKYLARK
Abstract:	
Pages:	0002
Pub Date:	8/22/1964
Release Date:	8/8/2000
Keywords:	CUBA OXCART RECONNAISSANCE FLIGHTS SKYLARK
Case Number:	F-1991-02144
Copyright:	0
Release Decision:	RIPPUB
Classification:	U



~~TOP SECRET~~

22 August 1964

MEMORANDUM FOR: Deputy Director for Science and Technology
SUBJECT : SKYLARK

1. It is essential as a matter of the highest national interest that we have an operational capability to conduct reconnaissance flights over Cuba with the OXCART vehicle as soon as possible and in any event no later than the first week in November, with characteristics on the order of Mach 2.8, altitude 80,000 feet, with a range of 2,500 nautical miles, or better as feasible, with four of this type aircraft.

2. You are to take all appropriate actions to insure that this highest priority objective of your Program is not in any way hindered by competing requirements of any kind. You should insure that the contractors, the field commanders, and anyone else having a direct impact upon the Program are aware of this highest priority objective, and you should bring to my attention at the earliest possible moment any proposal or directed course of action which might in any way interfere with our meeting this objective.

3. We seek in Project SKYLARK an urgent operational readiness and we must be careful to introduce into the program during the next several months only those modifications, procedures, and additional equipment, as are necessary to attain this objective.

(Signed) Marshall S. Carter

Marshall S. Carter
Lieutenant General, USA
Acting Director

you sh 25 11 20 20

MS:cmc
Distribution:
Orig - Addressee
1 - O/DCI
1 - Ex Dir
1 - ER
1 - DDCI

~~TOP SECRET~~

RELEASED AUG 2000

31-64
#5

b(1) b(3)

①



~~TOP SECRET~~

CONTROL NO. _____

REFERRED TO OFFICE	RECEIVED SIGNATURE	RECEIVED		RELEASED		SEEN BY	
		DATE	TIME	DATE	TIME	NAME & OFFICE SYMBOL	DATE

(OVER)

Handle Via Indicated Controls



Access to this document will be restricted to those persons cleared for the specific projects;

DX-CART

.....
.....

WARNING

This document contains information affecting the national security of the United States within the meaning of the espionage laws U. S. Code Title 18, Sections 793 and 794. The law prohibits its transmission or the revelation of its contents in any manner to an unauthorized person, as well as its use in any manner prejudicial to the safety or interest of the United States or for the benefit of any foreign government to the detriment of the United States. It is to be seen only by personnel especially indoctrinated and authorized to receive information in the designated control channels. Its security must be maintained in accordance with regulations pertaining to _____ System.

NEVADA AEROSPACE

~~TOP SECRET~~

GROUP 1
Excluded from automatic
downgrading and declassification



Title:	NRO EXCOM MEETING AT 3:30 P.M., ON THURSDAY, 10 SEPTEMBER
Abstract:	
Pages:	0004
Pub Date:	9/11/1964
Release Date:	8/8/2000
Keywords:	SOVIET UNION USSR RUSSIA MCCONE MR JOHNSON KELLY VANCE SECRETARY SKYLARK LEDFORD COLONEL BIRD WATCHER
Case Number:	F-1991-02144
Copyright:	0
Release Decision:	RIPPUB
Classification:	U



GROUP 1

~~SECRET~~

11 September 1964

MEMORANDUM FOR THE RECORD

SUBJECT: NRO ExCom Meeting at 3:30 p.m., on Thursday,
10 September

PRESENT: Mr. McCone, Secretary Vance, Dr. McMillan,
and General Carter

1. The meeting opened with distribution to each member of a copy of "SKYLARK Status Report for Week Ending 4 September." Each member read the entire report thoroughly and questions were asked and answered by those present. Great interest was shown in the report. Mr. McCone proposed and it was agreed to concentrate on getting BIRD WATCHER installed on two of the four aircraft as a minimum, if at all possible prior to 5 November. It was also agreed that Kelly Johnson should be informed that the Executive Committee of NRO laid great stress on this project and was following it closely on a weekly basis through the SKYLARK weekly reports. Action: DD/S&T to follow up on the above two requirements and report results.

2. The future U-2 program was then discussed and it was generally agreed that the best solution to the problem would be to modify existing SAC aircraft on a reasonable turn-in basis without establishing a crash production line -- say on the basis of modifying four per year. It was also agreed that we should see whether or not some other contractor was in a position to do the work on a much cheaper basis than Lockheed. Both of these agreements are to be considered in a plan to be submitted by Colonel Ledford. This plan is to develop a schedule of modifications and estimated completion dates and to include a listing of the actual modifications required. The general consensus was that modifying to U-2H was probably as far as we should go. Action: Colonel Ledford to prepare such a plan and show it to

b (1) b (3)

RELEASED AUG 2000

~~SECRET~~

36344-64



SECRET

General Carter prior to any further action with the NRO Executive Committee. Action: The charts used by Colonel Ledford at the prior briefing were supposed to have been reproduced, at my direction, on 8 x 10 sheets and provided all members of the Executive Committee. Mr. Vance was provided some sort of photographic copy about 3 x 4 inches, and these were not satisfactory. I gave him the book of 8 x 10 reproductions provided me by DD/S&T and he retained that book. I want to know why my instructions were not complied with, and soon.

3. Dr. McMillan then briefed on the problems causing the delay in the [redacted] and indicated that they centered around command and control instructions being reliably received -- apparently electrical malfunctions of some sort. The latest date for the [redacted] is now set at 25 September.

4. Secretary Vance then brought up the U-2 flight to cover [redacted] and was under the impression that it would be done from [redacted] and required either an American [redacted] I told him the flight had previously been done by [redacted] with [redacted] and I saw no reason why we could not follow this routine again. Certainly this would be a much better procedure than trying to do it out of [redacted]

5. Dr. McMillan reported that he did not yet have signatures of all members of the Land Committee on the Land report but that it was generally encouraging as to the prospects for [redacted] Certainly he was all ready to proceed on a Phase I type of operation, and it was agreed that when the final Land report was submitted, Dr. McMillan would review it and report to the Executive Committee prior to going ahead with any big program.

6. Mr. McCone then reported that in following up on suggestions made at previous meetings of the Executive Committee, a plan had been developed to establish a small CIA element to assist General Greer by having this element co-located with General Greer and conduct CIA CORONA activities on the West

SECRET



Coast. Mr. McCone said he contemplated having [REDACTED] in place in several weeks to be in charge of the CIA operations. [REDACTED] in addition to being the head of the West Coast CIA activities, would also provide a single point of contact for Greer and for Washington on CIA CORONA matters. He would provide advice and guidance to General Greer, would be responsible for all CIA contracting and all CIA security responsibilities. In addition, he would control the CIA group [REDACTED]. All of this was designed to give a single cohesive input to the CORONA program from the CIA and to revitalize our participation in that program. [REDACTED] would be ^{report to and be respons. to} ~~responsible to the needs of~~ General Greer and would ^{be} ~~have~~ direct lines of communication back to the DD/S&T here in Washington so that he could obtain additional advice, guidance, and assistance from our Headquarters competence as might be needed. We might augment [REDACTED] by the assignment of a couple of additional technical people at a later date. Mr. McCone pointed out that the successful operation of this plan required a clear-cut understanding of the Executive Committee as well as clear-cut instructions to Greer. I stated that these instructions should include participation of the CIA in all contractor/supplier meetings, a satisfactory working relationship with Aerospace Corporation who now has a systems engineering role, and a firm position in the Configuration Control Board or whatever new coordination mechanism is established for the system. Mr. Vance and Mr. McCone agreed that the veto concept of the Configuration Control Board was not working properly and that the Control Board, ~~whenever it was not in agreement,~~ ^{act as an advisory} should ~~present its conflicting~~ ^{board} views to General Greer for decision (and in the event these are major problems, such decision might have to be made back at the Washington level.) All of these points seemed to be agreed by everyone present but it was decided that I would prepare a memo for Dr. McMillan establishing the working relationships as we see them and proposing the type of guidance General Greer should receive from Dr. McMillan. Such a memo is being prepared and I will furnish the Executive Committee copies of it. Action: General Carter to prepare appropriate memo. *(used to review this)*

who would be responsible for final decision



██████████

7. Mr. McCone then brought up the problem of competing contracts being negotiated by General Greer along the ██████████ concept. He specifically mentioned Itek, Perkin-Elmer, and Fairchild along the lines of the Wheelon memo. Dr. McMillan indicated that he may have been responsible for Greer's actions and that Greer may have misunderstood his instructions. Mr. McCone said that a senior executive of Fairchild, whom he knew personally, had telephoned him inquiring as to a proposed contract with Greer which appeared to be in direct competition with a CIA program ~~he was aware of and which in fact would have been a contract to disprove the feasibility of ██████████~~ Dr. McMillan said he was not aware of this facet of the contract and would look into it right away. Mr. McCone pointed out that we had already contracted for a backup study by Perkin-Elmer in the event Itek proposals proved infeasible and that while he was always one to encourage the greatest diversity in think projects in order to ensure success, he thought it put the Government in an untenable position when two separate agencies ~~were negotiating on contracts designed to downgrade proposals of the other agency.~~ He said he would like to have this gone into thoroughly by Dr. McMillan and reported back to the next Executive Committee meeting. Action: None required by CIA until McMillan reports back.

(but not referring to the memo's contents)

for the same product as objective

8. There was general discussion of the USIB actions at the morning meeting same date, particularly with regard to the crisis satellite. Nothing new was added that had not already been discussed at USIB. Both Mr. McCone and Mr. Vance thought that perhaps we were looking at the same target too often in the Soviet Union and Dr. McMillan confirmed that he had the same impression. In other words, we should be careful that COMOR was not getting into a repetitive rut, doing the same thing over and over again with inadequate imagination as to new areas, new targets, and frequency of observation. Action: Mr. Reber, please take a look at this and give me an informal memo.

*

Marshall S. Carter
 Lieutenant General, USA
 Deputy Director

*Dictated but not read by General Carter

██████████



Title:	MEMORANDUM OF DISCUSSION AT LUNCHEON - SEPTEMBER 15TH SECRETARY RUSK'S DINING R
Abstract:	
Pages:	0004
Pub Date:	9/17/1964
Release Date:	6/19/2002
Keywords:	SECRETARY RUSK U-2 MISSION
Case Number:	F-1997-01346
Copyright:	0
Release Decision:	RIPPUB
Classification:	U



(b)(1)
(b)(3)
(S)

~~SECRET-NOV 1964~~

126
10/2

17 September 1964

MEMORANDUM FOR THE RECORD

SUBJECT: Memorandum of Discussion at Luncheon - September 15th
Secretary Rusk's Dining Room

Attending: Secy. Rusk, Secy. McNamara, McGeorge Bundy, Mr. McCone

1. Reviewed the needs for photographic [redacted]
[redacted] I explained the need for the U-2 mission as discussed and recorded in USIB meeting of September 10th. Rusk took the position that finite intelligence on when a [redacted] might be made was not of importance to him from a policy standpoint, as he knew it was inevitable and he knew of no political action he would take if finite information was given to him. Bundy seemed to agree. After extended discussion, I stated that I could not conceive of our failing to take some actions if finite information was in our hands, i. e., Rusk might contact Gromyko or Dobrynin; the President might communicate with Khrushchev privately; we might discuss the subject with our Allies, both in Europe and the Far East; and we might take some position in the press through leaks or planted information. Certainly we should discuss the subject with Thailand, Laos and South Vietnam. It was agreed that the embarrassment and consequences of failure outweighed the advantages and therefore, while the final decision was up to the President, Rusk would not recommend the mission. Bundy agreed. McNamara indicated his concurrence but was non-committal.

NOTE: In a 5:00 o'clock meeting, I suggested that the mission could be accomplished [redacted]
[redacted] immediately agreed that this plan was a good one and should be approved. Subsequently at a meeting with the President (which I did not attend because of another appointment) the President approved the Takhli-Lop Nor plan and this was reported to me by McGeorge Bundy in a telephone call.



2. During this conversation I raised the question of [redacted] This question was discussed by me with [redacted] and some others but no actions had been taken to implement the plan. All seemed to agree that this might be a good idea.

ACTION: I wish appropriate people in CIA to consider this, discuss it at appropriate levels in the Department, discuss it in further detail with Defense and McGeorge Bundy and if all are in agreement, to promptly take the matter up with [redacted] and appropriate people [redacted] and then to implement the program if all are in agreement.

3. The use of drones was discussed. [redacted] Drones should be flown when necessary to accumulate essential information and should be complementary but second in priority to flying of the U-2 when and if U-2's were available.

[redacted]

4. There was an extensive discussion of proposed DCI briefings of Heads of State. McNamara raised the issue in a very antagonistic way, stating that he had not seen the briefing paper until a half an hour before the luncheon. The Joint Chiefs had not seen it at all, etc., etc. He said that his quick reaction was that "not more than 40% of the proposed information should be given in the briefings and his preference would be to have no briefing at all." Rusk sharply differed with McNamara. He said the subject had been under discussion for a number of months, the Defense Department representatives were in on every phase and that the reasons for the briefing were important and he wished the briefings to go forward. McCone stated that in his opinion there were four important reasons: One, to further develop the confidence of our Allies in our estimates; Two, to establish the importance of the peaceful uses of satellites; Three, to show the contributions, and the limitations, of satellites in any disarmament steps; and Four, to discuss in detail the inadequacy of satellites for reconnaissance over Cuba. Rusk concurred in these objectives, in

~~SECRET-NOFORN~~



fact he stated and restated them during the long discussion in several different ways, but covering essentially the same points. I said that in view of the discussion I would like to call the whole briefing off and Rusk said this could not be done because of the elaborate arrangements which had been made. McNamara said that he thought a few hours work on the part of the Thompson Committee and discussions with the Joint Chiefs would clarify the problem. I said that that was all fine but if the results of such discussions were to sterilize the briefing to the point that I would "advise those whom I was briefing concerning the time of day and the condition of the weather, I did not think it would be advisable to go, and I would not go. McNamara said he didn't think such a sterile answer would come forward. I agreed to McNamara's program, a meeting for 5:00 p. m. of the Thompson Committee was ordered and it was agreed the Joint Chiefs would consider the problem the following morning, early.

5. We discussed at some length the question of the Cuban overflight problem. I explained the status of SKYLARK. I pointed out that the OXCART flying over Cuba would be far less vulnerable than the U-2, but not entirely invulnerable; however it would be known because of the sonic boom in addition to radar detection. McNamara felt that the OXCART would not be vulnerable on the initial flights but if we engaged in frequent flight over a pre-determined pattern the Cubans might put some of their SAMs in a state of alert which would very possibly catch an OXCART. He then said that he thought that one plane a month would be all that would be necessary in order to secure complete coverage of Cuba, once every 30 days which was about all that was required. I said that such coverage would meet USIB's requirements [redacted]

[redacted] but that I was sure a study of the history of weather over Cuba from records of the last two years of operations would indicate that with few exceptions several flights, rather than one flight a month, would be required for substantial, though not absolutely, total coverage of the Island.

It was agreed that the subject should be explored by COMOR and NPIC and a report prepared. Also a hard study should be made of vulnerability.

ACTION: COMOR should prepare a study on the probability of meeting USIB's requirements of coverage



[redacted] and make a judgment as to the number of flights per month, by month, over a 12-month span, required from November 1964 to November 1965 in order to accomplish acceptable coverage of the Island with usable photography and second, DD/S&T, collaborating to the extent necessary with NRO or Dr. Fubini, should make a report on the vulnerability of the OXCART under the SKYLARK program, using all available information on the capabilities of the Cuban radar system.

6. Question was raised by McGeorge Bundy of the problem of forward planning. It was felt there was need for a fresh look at our policies in very many areas of the world and our relationship with such people as Sukarno, Nasser, Castro, etc., etc. It was felt that no forward-planning activities should go forward immediately because of the implications, but probably in November and December intense studies should be made of the whole series of problems. There was no indication that CIA should necessarily participate as these are all policy matters although as the time for making the studies approaches, undoubtedly there will be a very important role for CIA to play.

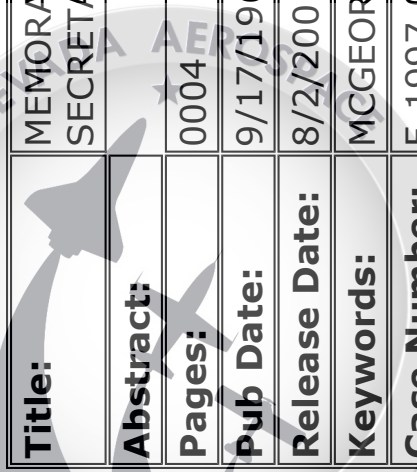
ACTION: I should discuss this role privately with Helms, Cline and Kent, and possibly one or two others in order that private and unofficial advance thinking might be done on this very important but sensitive subject.

7. [redacted]

ACTION: Discuss this with Helms and possibly others prior to departure today. ✓

JAM(tape):mfb:mcm





Title:	MEMORANDUM OF DISCUSSION AT LUNCHEON - SEPTEMBER 15TH SECRETARY RUSK'S DINING R
Abstract:	
Pages:	0004
Pub Date:	9/17/1964
Release Date:	8/2/2001
Keywords:	MCGEORGE BUNDY MCCONE LUNCHEON DISCUSSION RUSK MCNAMARA
Case Number:	F-1997-01346
Copyright:	0
Release Decision:	RIPPUB
Classification:	U



128
102

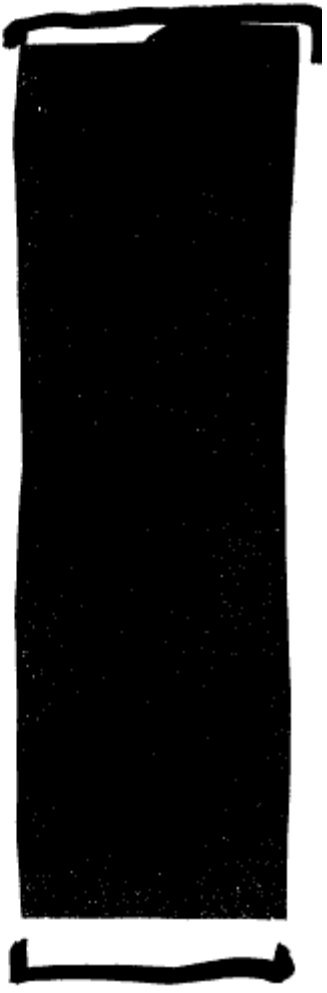
17 September 1964

MEMORANDUM FOR THE RECORD

SUBJECT: Memorandum of Discussion at Luncheon - September 15th
Secretary Rusk's Dining Room

Attending: Secy. Rusk, Secy. McNamara, McGeorge Bundy, Mr. McCone

1. Reviewed the needs for [redacted] (b)(1) & [redacted] (b)(3) as discussed and recorded in USIB meeting of September 10th. Rusk took the position that finite intelligence on when a [redacted] might be made was not of importance to him from a policy standpoint, as he knew it was inevitable and he knew of no political action he would take if finite information was given to him. Bundy seemed to agree. After extended discussion, I stated that I could not conceive of our failing to take some actions if finite information was in our hands, i. e., Rusk might contact Gromyko or DoDrynin; the President might communicate with Khrushchev privately; we might discuss the subject with our Allies, both in Europe and the Far East; and we might take some position in the press through leaks or planted information. Certainly we should discuss the subject with Thailand, Laos and South Vietnam. It was agreed that the embarrassment and consequences of failure outweighed the advantages and therefore, while the final decision was up to the President, Rusk would not recommend the mission. Bundy agreed. McNamara indicated his concurrence but was non-committal.



(b)(1)

(b)(3)



2. During this conversation I raised the question of [redacted] on U-2's. This question was discussed by me with [redacted] and some others but no actions had been taken to implement the plan. All seemed to agree that this might be a good idea. (b)(1), (b)(3)

ACTION: I wish appropriate people in CIA to consider this, discuss it at appropriate levels in the Department, discuss it in further detail with Defense and McGeorge Bundy and if all are in agreement, to promptly take the matter up with [redacted] and appropriate people [redacted] and then to implement the program if all are in agreement.

3. The use of drones was discussed. [redacted] Drones should be flown when necessary to accumulate essential information and should be complementary but second in priority to flying of the U-2 when and if U-2's were available. (b)(1), (b)(3)

[redacted]

4. There was an extensive discussion of proposed DCI briefings of Heads of State. McNamara raised the issue in a very antagonistic way, stating that he had not seen the briefing paper until a half an hour before the luncheon. The Joint Chiefs had not seen it at all, etc., etc. He said that his quick reaction was that "not more than 40% of the proposed information should be given in the briefings and his preference would be to have no briefing at all." Rusk sharply differed with McNamara. He said the subject had been under discussion for a number of months, the Defense Department representatives were in on every phase and that the reasons for the briefing were important and he wished the briefings to go forward. McCone stated that in his opinion there were four important reasons: One, to further develop the confidence of our Allies in our estimates; Two, to establish the importance of the peaceful uses of satellites; Three, to show the contributions, and the limitations, of satellites in any disarmament steps; and Four, to discuss in detail the inadequacy of satellites for reconnaissance over Cuba. Rusk concurred in these objectives, in



fact he stated and restated them during the long discussion in several different ways, but covering essentially the same points. I said that in view of the discussion I would like to call the whole briefing off and Bosk said this could not be done because of the elaborate arrangements which had been made. McNamara said that he thought a few hours work on the part of the Thompson Committee and discussions with the Joint Chiefs would clarify the problem. I said that that was all fine but if the results of such discussions were to sterilize the briefing to the point that I would advise those whom I was briefing concerning the time of day and the condition of the weather, I did not think it would be advisable to go, and I would not go. McNamara said he didn't think such a sterile answer would come forward. I agreed to McNamara's program, a meeting for 5:00 p.m. of the Thompson Committee was ordered and it was agreed the Joint Chiefs would consider the problem the following morning, early.

5. We discussed at some length the question of the Cuban overflight problem. I explained the status of SKYLARK. I pointed out that the OXCART flying over Cuba would be far less vulnerable than the U-2, but not entirely invulnerable; however it would be known because of the sonic boom in addition to radar detection. McNamara felt that the OXCART would not be vulnerable on the initial flights but if we engaged in frequent flight over a pre-determined pattern the Cubans might put some of their SAMs in a state of alert which would very possibly catch an OXCART. He then said that he thought that one plane a month would be all that would be necessary in order to secure complete coverage of Cuba, once every 30 days which was about all that was required. I said that such coverage would meet USIB's requirements [REDACTED] but that I was sure a study of the history of weather over Cuba from records of the last two years of operations would indicate that with few exceptions several flights, rather than one flight a month, would be required for substantial, though not absolutely, total coverage of the Island.

(b)(1)
(b)(7)(C)

It was agreed that the subject should be explored by COMOR and NPIC and a report prepared. Also a hard study should be made of vulnerability.

ACTION: COMOR should prepare a study on the probability of meeting USIB's requirements of coverage



(b)(1)
(b)(c)

[redacted] and make a judgment as to the number of flights per month, by month, over a 12-month span, required from November 1964 to November 1965 in order to accomplish acceptable coverage of the Island with usable photography and second, DD/S&T, collaborating to the extent necessary with NRO or Dr. Fubini, should make a report on the vulnerability of the OXCART under the SKYLARK program, using all available information on the capabilities of the Cuban radar system.

6. Question was raised by McGeorge Bundy of the problem of forward planning. It was felt there was need for a fresh look at our policies in very many areas of the world and our relationship with such people as Sukarno, Nasser, Castro, etc., etc. It was felt that no forward-planning activities should go forward immediately because of the implications, but probably in November and December intense studies should be made of the whole series of problems. There was no indication that CIA should necessarily participate as these are all policy matters although as the time for making the studies approaches, undoubtedly there will be a very important role for CIA to play.


ACTION: I should discuss this role privately with Helms, Cline and Kent, and possibly one or two others in order that private and unofficial advance thinking might be done on this very important but sensitive subject.

(b)(1)
(b)



ACTION: Discuss this with Helms and possibly others prior to departure today. ✓

JAM(tape):mfb:mcm



Title:	F-12 EMERGENCY GROUND PROCEDURES MANUAL
Abstract:	
Pages:	0057
Pub Date:	6/15/1965
Release Date:	5/2/2006
Keywords:	A-12 MANUALS
Case Number:	F-1995-01611
Copyright:	0
Release Decision:	RIPPUB
Classification:	U

APPROVED FOR RELEASE
DATE: MAY 2006

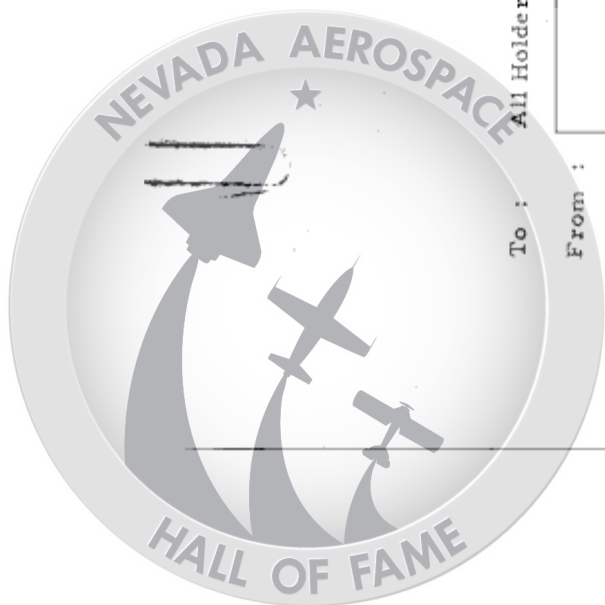
(b) (3)

15 June 1965

To : All Holders of "F-12 Emergency Ground Procedures Manual"

From :

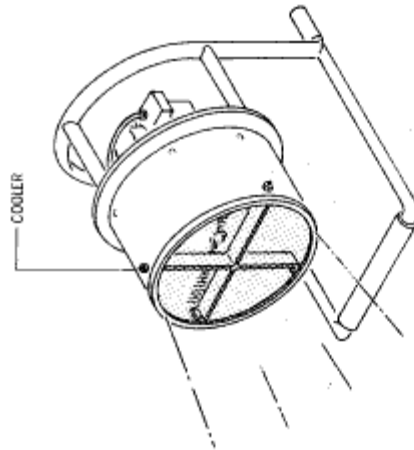
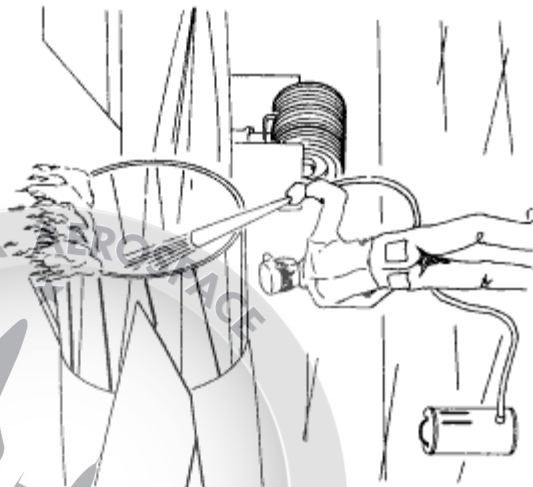
The attached illustration is a changed page that is to be inserted into your F-12 Emergency Ground Procedures Manual (s), copy number (s) 3 and 4. Please remove and destroy existing illustration and replace with the attached.



TAIL PIPE FIRES

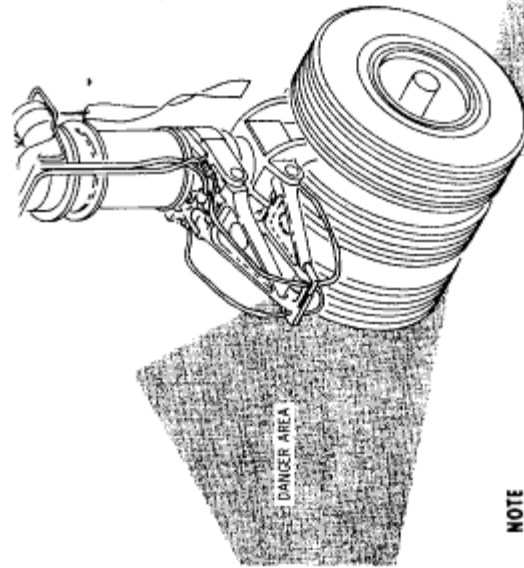
TAIL PIPE FIRES USUALLY RESULT FROM EXCESS FUEL COLLECTING IN THE AFTERBURNER SECTION AFTER SHUT-DOWN, OR DURING STARTING CYCLES. IN CASE OF FIRE (WITH GROUND START UNIT ENGAGED) PROCEED AS FOLLOWS.

- 1 THROTTLE OFF.
- 2 EMERGENCY FUEL SHUT-OFF VALVE: (GUARD UP)
- 3 IF POSSIBLE, MAINTAIN STARTING OPERATION UNTIL ALL EVIDENCE OF FIRE HAS DISAPPEARED. IF FIRE DOES NOT BLOW OUT OR PERSISTS, DISCONTINUE START OPERATION AND FIGHT AS OIL FIRE BY APPLYING CO₂ IN SHORT BURSTS INTO AFTERBURNER SECTION.



WARNING

EXCESSIVE BRAKE HEATING WEAKENS TIRE AND WHEEL STRUCTURE AND INCREASES TIRE PRESSURE. THE AREAS INBOARD AND OUTBOARD OF WHEEL SHOULD BE AVOIDED.



NOTE

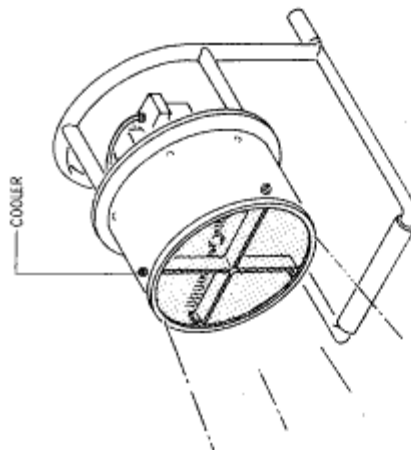
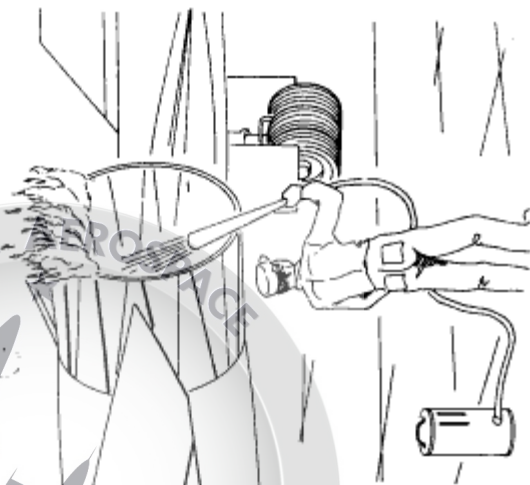
DIRECT COOLING AIR ONTO HOT WHEELS

THERMAL RELIEF PLUGS IN WHEELS RELIEVE TIRE PRESSURE AT 450° F (232.2° C)

TAIL PIPE FIRES

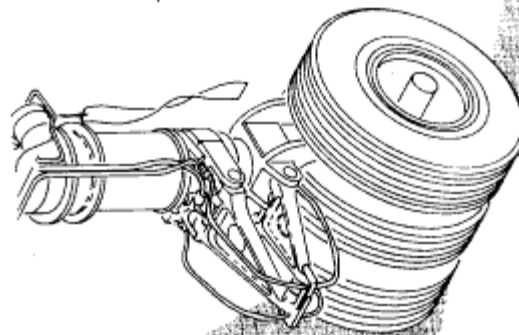
TAIL PIPE FIRES USUALLY RESULT FROM EXCESS FUEL COLLECTING IN THE AFTERBURNER SECTION AFTER SHUT-DOWN, OR DURING STARTING CYCLES. IN CASE OF FIRE (WITH GROUND START UNIT ENGAGED) PROCEED AS FOLLOWS.

1. THROTTLE OFF.
2. EMERGENCY FUEL SHUT-OFF VALVE: (GUARD UP)
3. IF POSSIBLE, MAINTAIN STARTING OPERATION UNTIL ALL EVIDENCE OF FIRE HAS DISAPPEARED. IF FIRE DOES NOT BLOW OUT OR PERSISTS, DISCONTINUE START OPERATION AND FIGHT AS OIL FIRE BY APPLYING CO₂ IN SHORT BURSTS INTO AFTERBURNER SECTION.



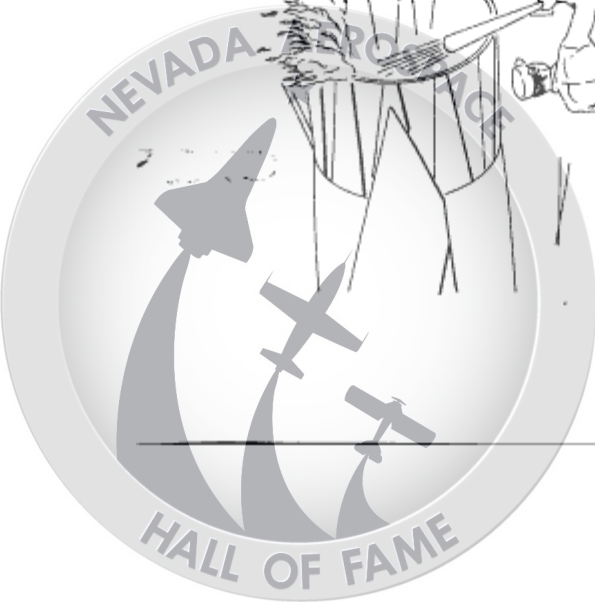
WARNING

EXCESSIVE BRAKE HEATING WEAKENS TIRE AND WHEEL STRUCTURE AND INCREASES TIRE PRESSURE. THE AREAS INBOARD AND OUTBOARD OF WHEEL SHOULD BE AVOIDED.



NOTE

DIRECT COOLING AIR ONTO HOT WHEELS
THERMAL RELIEF PLUGS IN WHEELS RELIEVE TIRE PRESSURE AT 450°F (232.2°C)



6/13

F-12

EMERGENCY GROUND PROCEDURES MANUAL





TABLE OF CONTENTS

SECTION I	General Information
SECTION II	Safety Precautions and Emergency Procedures
SECTION III	Ground Handling



SECTION I
GENERAL INFORMATION

TABLE OF CONTENTS

Paragraph	Title	Page
1-1	GENERAL INFORMATION	1-1
1-2	General Arrangement	1-1
1-3	Ground Safety Precautions	1-1
1-5	Ground Handling	1-1
1-7	Access Openings	1-1
1-9	Runway/Taxiway Strength Capabilities	1-2



SECTION I
GENERAL INFORMATION

LIST OF ILLUSTRATIONS

Figure No.	Title	Page
1-1	General Arrangement	1-3
1-2	Emergency Access Panels	1-4

1-1. GENERAL INFORMATION.

1-2. General Arrangement. (See Figure 1-1.)

1-3. Ground Safety Precautions.

1-4. The safety precautions and emergency procedures contained in

Section II and illustrations provided must be strictly adhered to to prevent injury to personnel and damage to the aircraft.

1-5. Ground Handling.

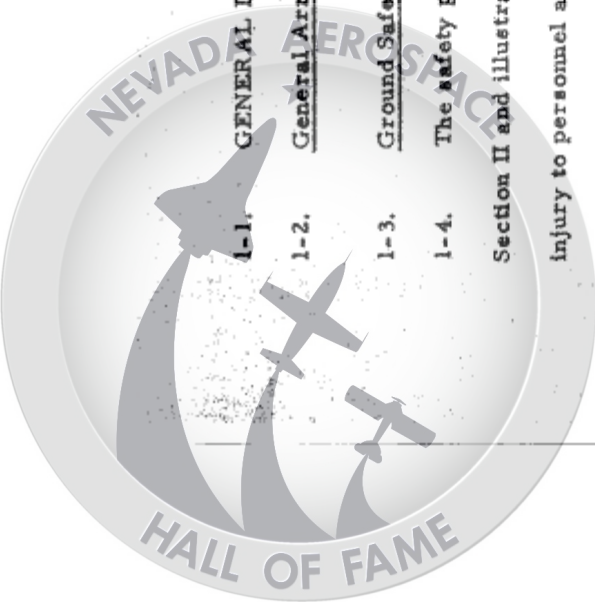
1-6. The Ground Handling section, Section III, contains information and illustrations as to the handling of aircraft during emergency ground operations. This information includes instructions on towing, pneumatic bag lifting and hoisting the aircraft.

CAUTION

All ground rescue crews shall wear asbestos suits and gloves due to the possibility of encountering hot aircraft structure resulting from high speed flight.

1-7. Access Openings.

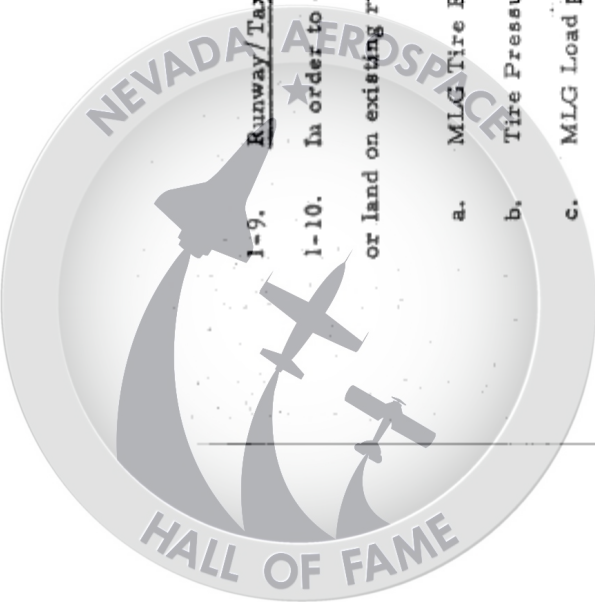
1-8. Figure 1-2 will locate and identify emergency access panels and openings on the upper and lower surfaces of the aircraft fuselage and wings.

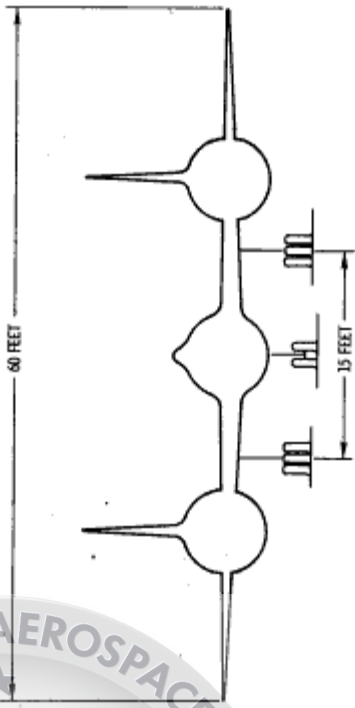


1-9. Runway/Taxiway Strength Capabilities.

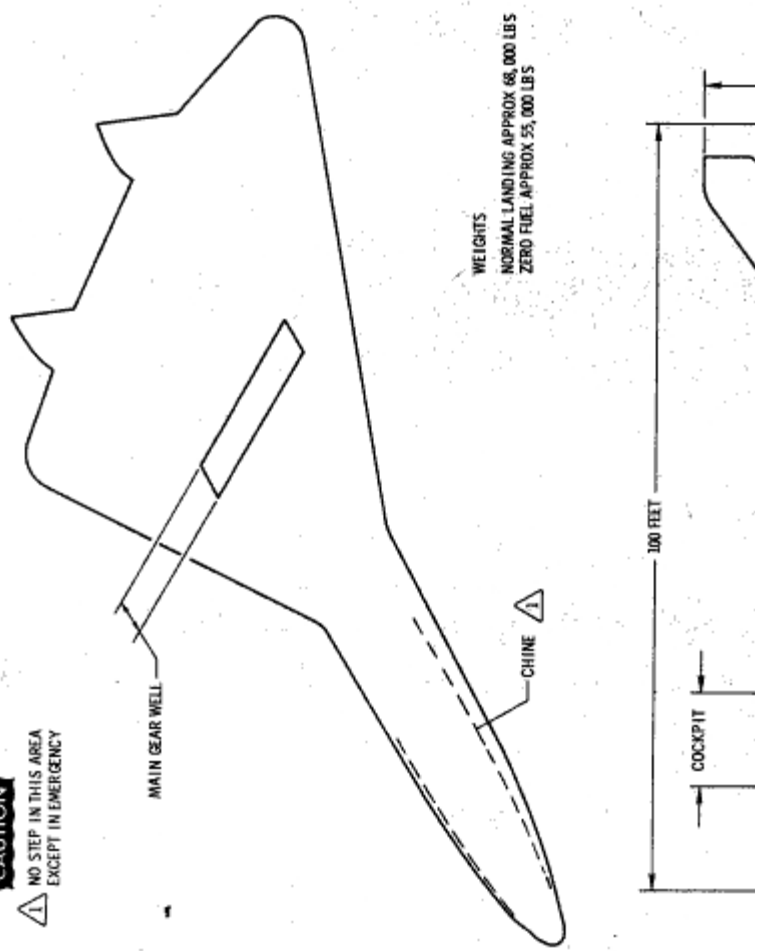
1-10. In order to determine if this aircraft can taxi on existing taxiways or land on existing runways, the following data is provided:

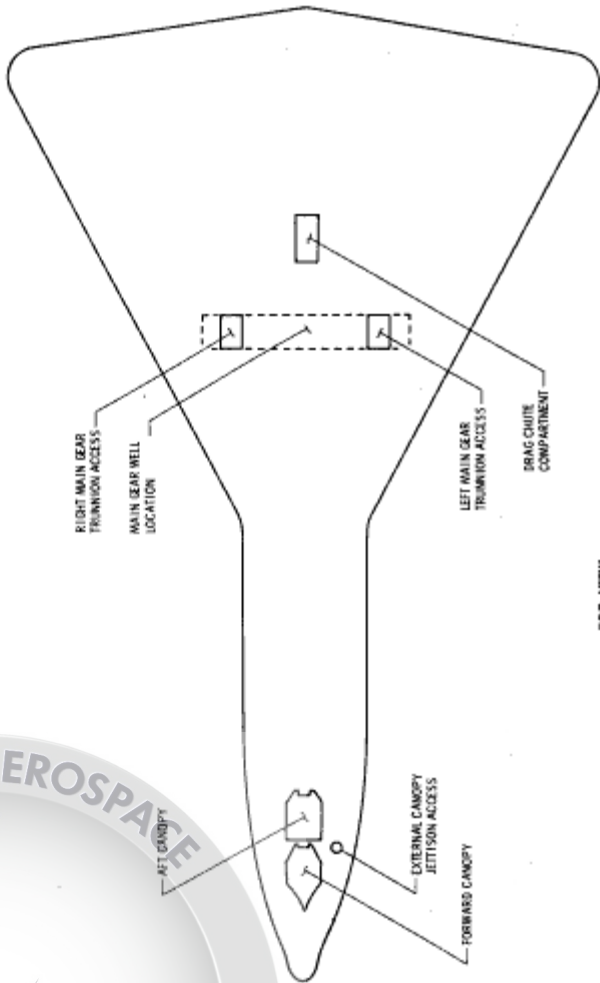
- a. MLG Tire Foot Print 50 inches² per tire.
- b. Tire Pressures 365 psig. (Dry Nitrogen)
- c. MLG Load per tire 17, 500 lbs.
- d. NLG Load per tire 9, 800 lbs.
- e. UCI Index, over 300.



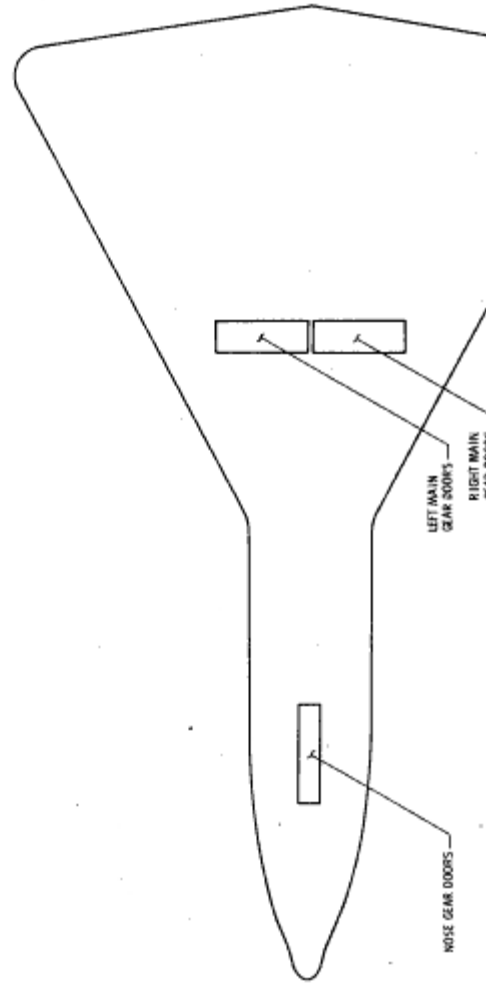


CAUTION
⚠ NO STEP IN THIS AREA
EXCEPT IN EMERGENCY





TOP VIEW





SECTION II
SAFETY PRECAUTIONS AND EMERGENCY PROCEDURES

TABLE OF CONTENTS

Paragraph No.	Title	Page
2-1	Safety Precautions and Emergency Procedures	2-1
2-2	Ground Safety Precautions	2-1
2-5	Crash Rescue Procedures	2-1
2-23	Damage Prevention	2-21
2-39	Health Hazards	2-27



SECTION II
SAFETY PRECAUTIONS AND EMERGENCY PROCEDURES

LIST OF ILLUSTRATIONS

Figure No.	Title	Page
2-1	Internal Safety Devices	2-2
2-2	External Safety Devices	2-5
2-3	Crash Rescue Procedures	2-7
2-4	TEB Tank and Lines Location	2-20
2-5	Engine and Wheel Brake Fires	2-25

2-1. SAFETY PRECAUTIONS AND EMERGENCY PROCEDURES.

2-2. Ground Safety Precautions.

2-3. Internal Safety Devices. (See Figure 2-1.)

2-4. External Safety Devices. (See Figure 2-2.)

2-5. Crash Rescue Procedures.

2-6. All safety precautions listed in the following paragraphs and

illustrations shall be strictly adhered to prevent injury to all personnel involved.

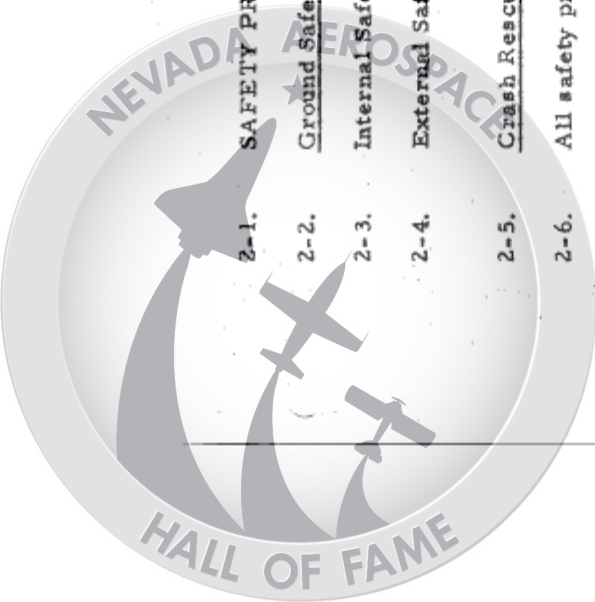
Note

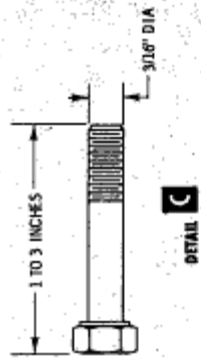
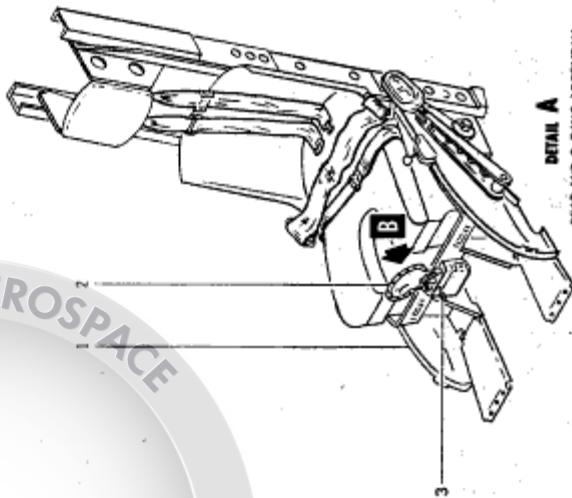
The following information is intended for crash site use to assist rescue crews in determining the most practical and safest way to aid flight crew members in evacuating the aircraft.

2-7. Crash Rescue Markings. (See Figure 2-3, Sheet 1.)

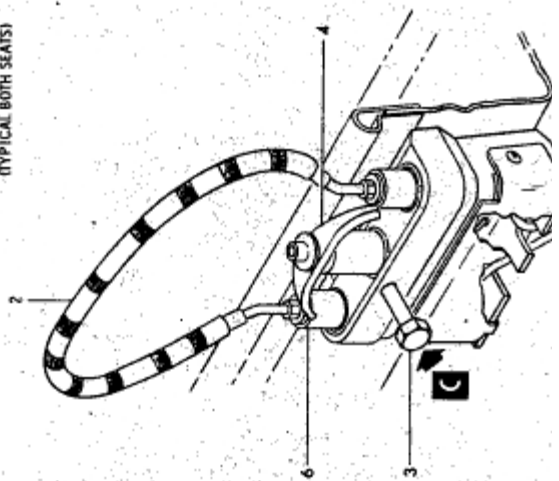
2-8. Crash Rescue Procedures.

2-9. Removal of canopies by the external jettison method is the primary means of gaining immediate access to the cockpit. (See Figure 2-3, Sheet 2.)





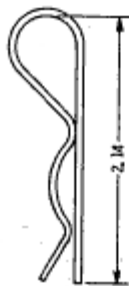
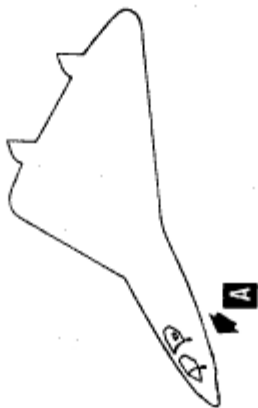
- 1 EJECTION SEAT ASSEMBLY
- 2 D-RING HANDLE (PRIMARY)
- 3 BOLT (1/8" DIA)
- 4 TEE HANDLE (SECONDARY)
- 5 INITIATOR CABLE
- 6 EXTENSION CYLINDER AND TUBE (2 PLACES EACH ASSEMBLY)



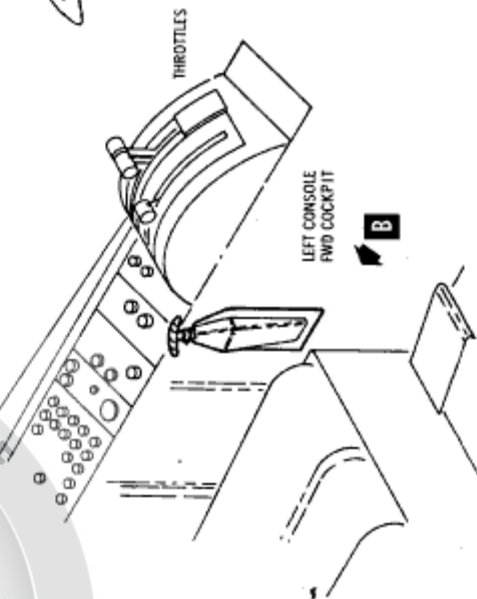


WARNING

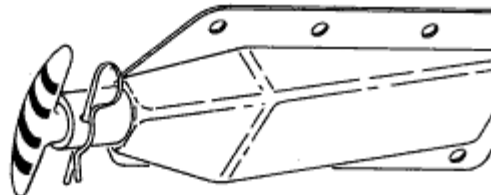
SAFETY PINS ARE TO BE
 INSTALLED IN BOTH PLACES,
 IMMEDIATELY AFTER
 CANOPYES ARE OPEN



PIN .051 MUSIC WIRE
 OR EQUIV



VIEW A

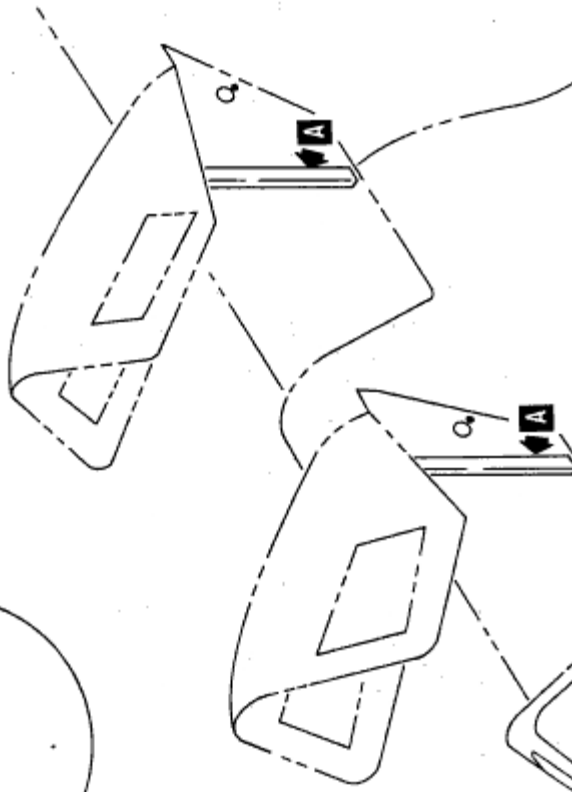
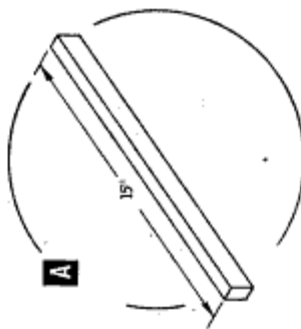


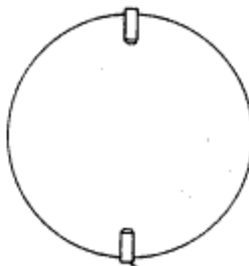
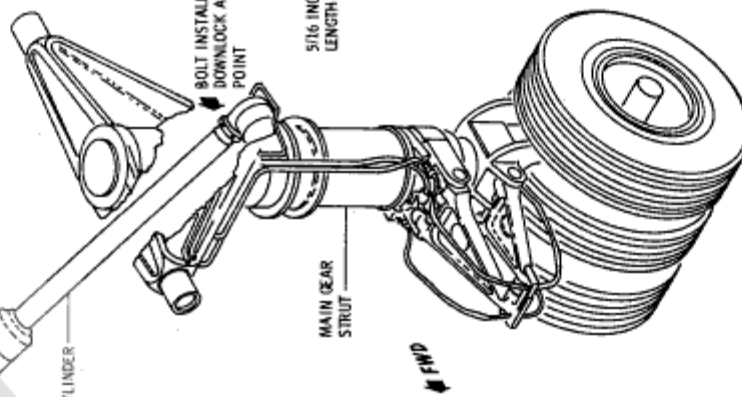
NOTE
 CANOPY JETTISON HANDLE
 ALSO INSTALLED AT LEFT
 SIDE CONSOLE AFT COCKPIT

TYPICAL FWD AND
 AFT COCKPITS



NOTE
AFTER CANOPY(S) ARE OPENED, USE
SUITABLE BLOCK TO SUPPORT CANOPY(S)
IF NORMAL HOLD OPEN MECHANISM IS
INOPERATIVE

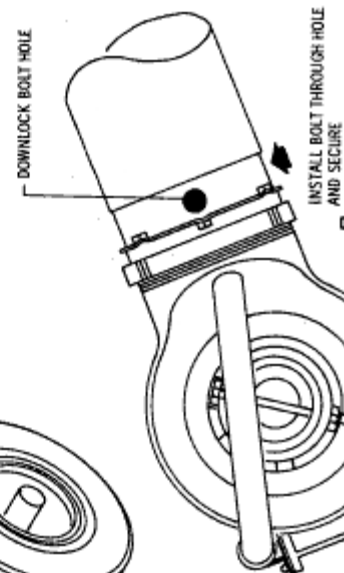




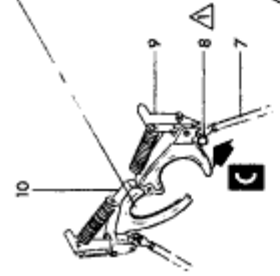
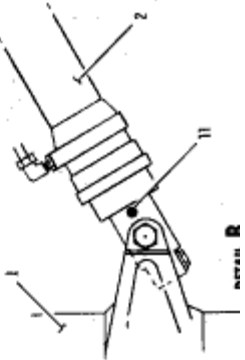
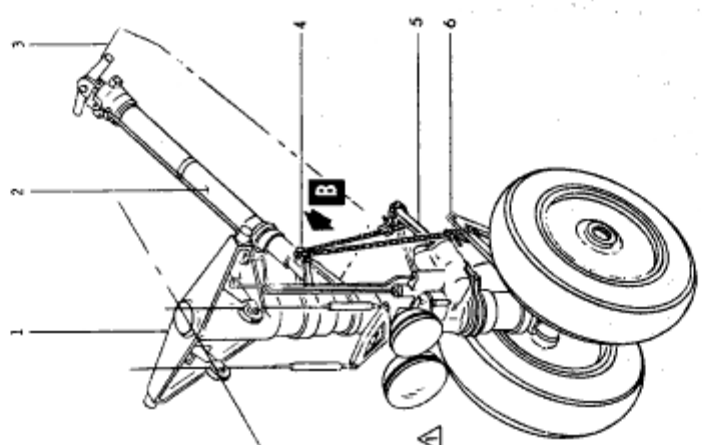
5/16 INCH MAX. BOLTS,
LENGTH ONE INCH

BOLT INSTALLED IN
DOWNLOCK AT THIS
POINT

SOME ACFT HAVE THIS DOWNLOCK
CONFIGURATION. TWO BOLTS ARE
REQUIRED. BOLTS MAY BE SECURED
BY USING TAPE.



NOTE
LEFT MAIN GEAR SHOWN
RIGHT GEAR IDENTICAL.



DETAIL A
UPLOCK AND ACTUATING CYLINDER
SAFETY PIN ASSEMBLIES

DETAIL B

DETAIL C
NON CADMIUM PLATED BOLTS PREFERRED

NOTE
▲ TO BE USED WHEN WORKING IN
WHEEL WELL ONLY.

- 1 NOSE LANDING GEAR ASSEMBLY
- 2 ACTUATING CYLINDER (DRAG STRUT)
- 3 GEAR DOOR (AFT)
- 4 SAFETY BOLT (ACTUATING CYLINDER)
- 5 SCISSOR'S BUMPER



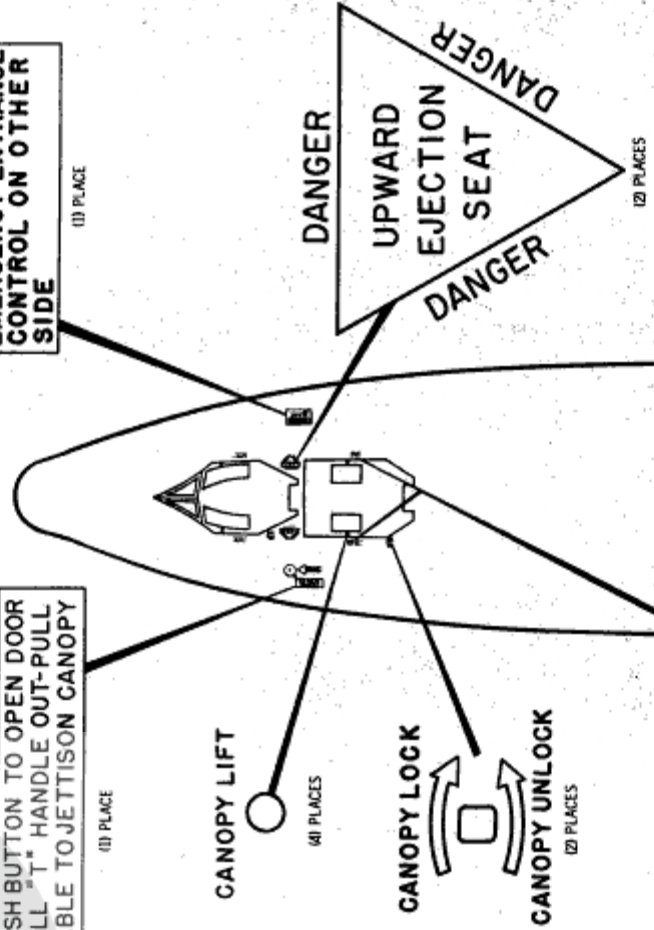
RESCUE

1. PUSH BUTTON TO OPEN DOOR
2. PULL "T" HANDLE OUT-PULL CABLE TO JETTISON CANOPY

(1) PLACES

RESCUE
EMERGENCY ENTRANCE CONTROL ON OTHER SIDE

(1) PLACES



CANOPY LIFT

(4) PLACES

CANOPY LOCK

CANOPY UNLOCK

(2) PLACES

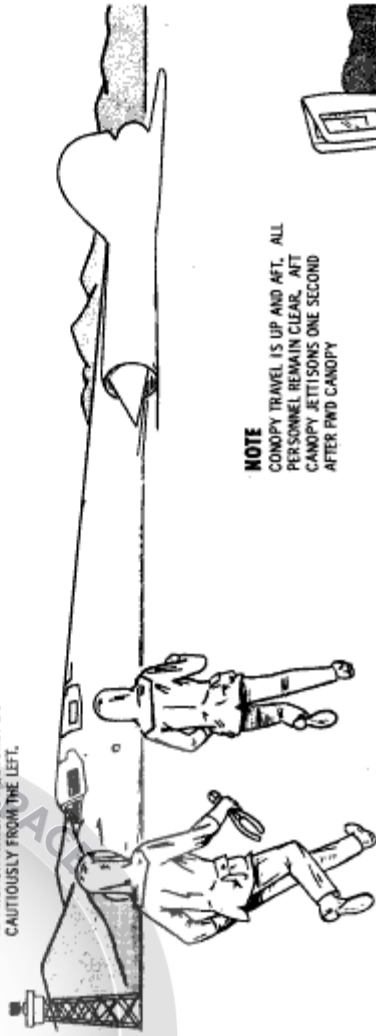
DANGER
UPWARD
EJECTION
SEAT
DANGER

(2) PLACES

WARNING
THIS AIRCRAFT CONTAINS
A SEAT CONTAINING AN

CRASH RESCUE PROCEDURES

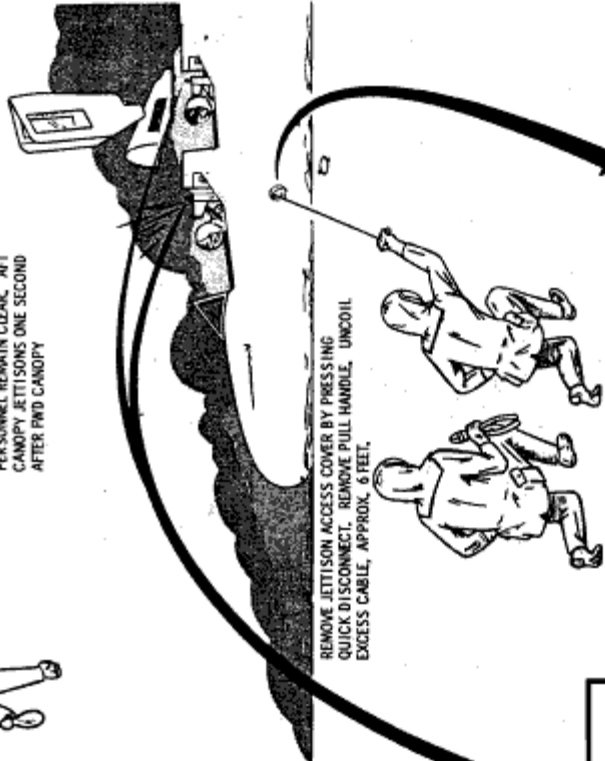
APPROACH AIRCRAFT QUICKLY BUT CAUTIOUSLY FROM THE LEFT.



NOTE

CANOPY TRAVEL IS UP AND AFT. ALL PERSONNEL REMAIN CLEAR. JETTISON CANOPY JETTISONS ONE SECOND AFTER PWD CANOPY

REMOVE JETTISON ACCESS COVER BY PRESSING QUICK DISCONNECT. REMOVE PULL HANDLE. UNCOIL EXCESS CABLE, APPROX. 6 FEET.



WARNING

DO NOT APPLY PRESSURE TO CABLE UNTIL FULLY UNCOILED. PULL SHARPLY AND CANOPIES WILL JETTISON INSTANTLY



EMERGENCY RELEASE



2-10. Conditions existing during an emergency could possibly dictate the method required to remove the canopies. To remove both canopies employing the manual opening mechanism, see Figure 2-3, Sheets 3 and 4.

2-11. Forcible Cockpit Entry. (See Figure 2-3, Sheet 5.)

2-12. Currently a study is under way to determine the most practical and safest means of forcible cockpit entry.

WARNING

A hazardous condition exists regardless of the method used to open and remove the canopies.

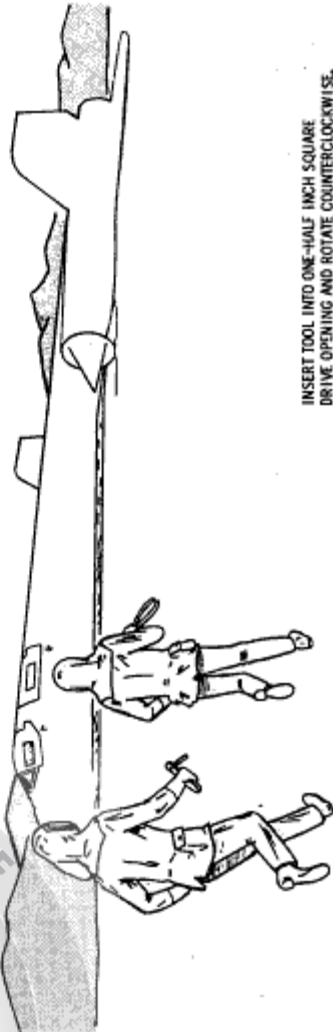
It is imperative that ballistics lines to ejection seat catapults be severed immediately upon gaining access to the cockpits.

2-13. Once access to the cockpits is possible, rescue personnel can begin immediately with flight crew removal procedures. (See Figure 2-3, Sheet 6.)

2-14. Procedures as shown in Figure 2-3, Sheet 6, represent the quickest and safest method of releasing both pilot and FCO from arresting harness, emergency equipment, seat and subsequent removal from the cockpits.

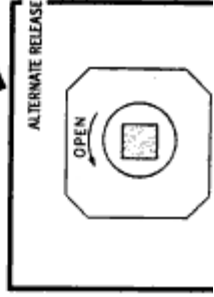
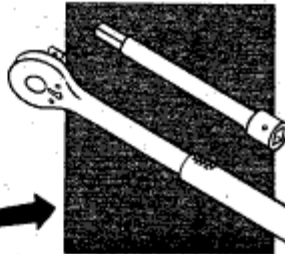


CRASH RESCUE PROCEDURES



APPROACH AIRCRAFT QUICKLY BUT CAUTIOUSLY FROM THE LEFT. ONE MAN WILL CARRY BOLT CUTTERS AND ONE MAN WILL CARRY SPECIAL TOOL TO OPEN CANOPIES MANUALLY.

INSERT TOOL INTO ONE-HALF INCH SQUARE DRIVE OPENING AND ROTATE COUNTERCLOCKWISE.

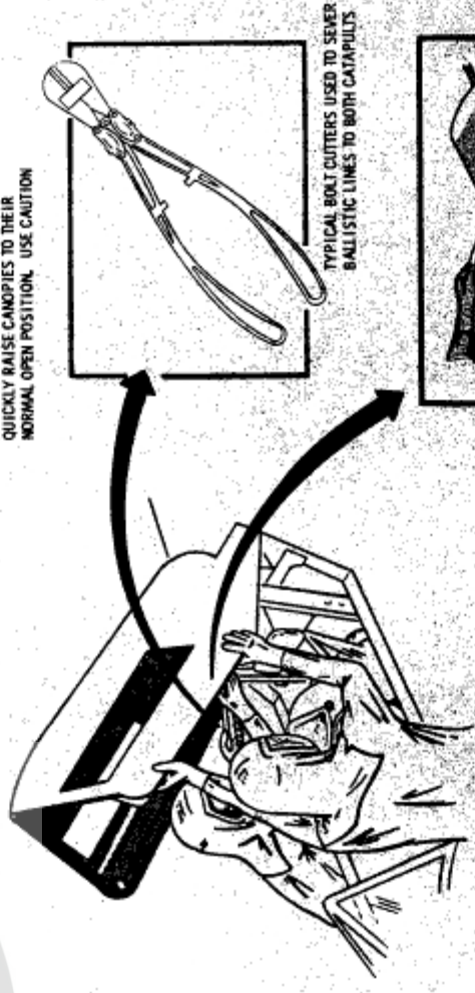




CRASH RESCUE PROCEDURES



QUICKLY RAISE CANOPIES TO THEIR NORMAL OPEN POSITION. USE CAUTION



TYPICAL BOLT CUTTERS USED TO SEVER BALLISTIC LINES TO BOTH CATAPULTS

CAUTION
IMMEDIATELY SEVER BALLISTIC LINES TO CATAPULTS WHEN CANOPIES ARE OPENED



CANOPY HINGE PIN WILL SPLIT WHEN CANOPY IS FORCED AFT.





Forcible Cockpit Entry.

(To be added when available)

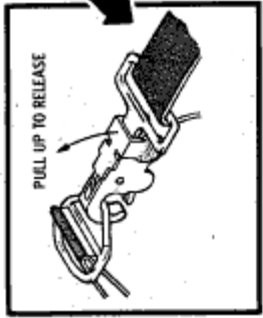
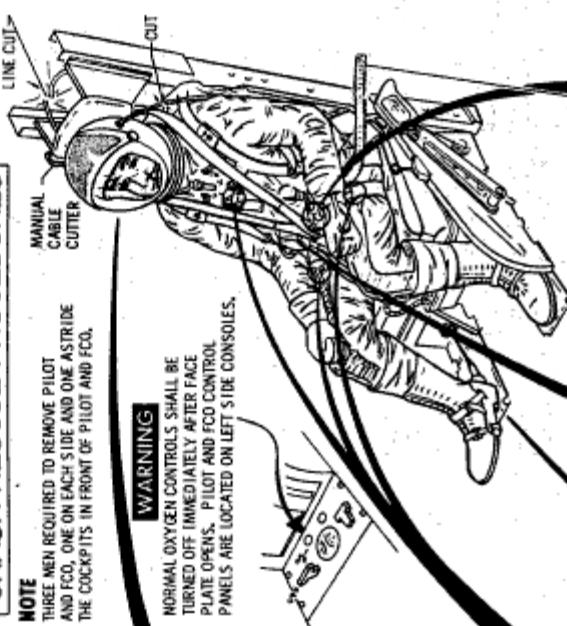
CRASH RESCUE PROCEDURES

NOTE

THREE MEN REQUIRED TO REMOVE PILOT AND FCO, ONE ON EACH SIDE AND ONE ASTRIDE THE COCKPITS IN FRONT OF PILOT AND FCO.

WARNING

NORMAL OXYGEN CONTROLS SHALL BE TURNED OFF IMMEDIATELY AFTER FACE PLATE OPENS. PILOT AND FCO CONTROL PANELS ARE LOCATED ON LEFT SIDE CONSOLES.

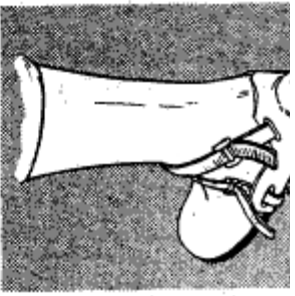


RELEASE AT THREE PLACES SHOWN TO REMOVE PILOT AND FCO FROM PARACHUTES.

SUIT VENT HOSE WILL DISCONNECT UPON REMOVAL.

EMERGENCY OXYGEN LINES WILL DISCONNECT MANUALLY

NORMAL OXYGEN LINES WILL DISCONNECT UPON REMOVAL AT SEAT CONSOLE.



EJECTION SEAT ASSEMBLY





Notes

a. The intercom cord is designed to disconnect with an 18 pound pull, however, this cord should be severed to prevent any interference during removal.

b. The helmet face plate could require up to two minutes for automatic opening after the oxygen supply is shutoff. Press the left knob on helmet down and open face plate immediately.

2-15. Pressure Suit Handling. (See Figure 2-3, Sheets 7 and 8.)

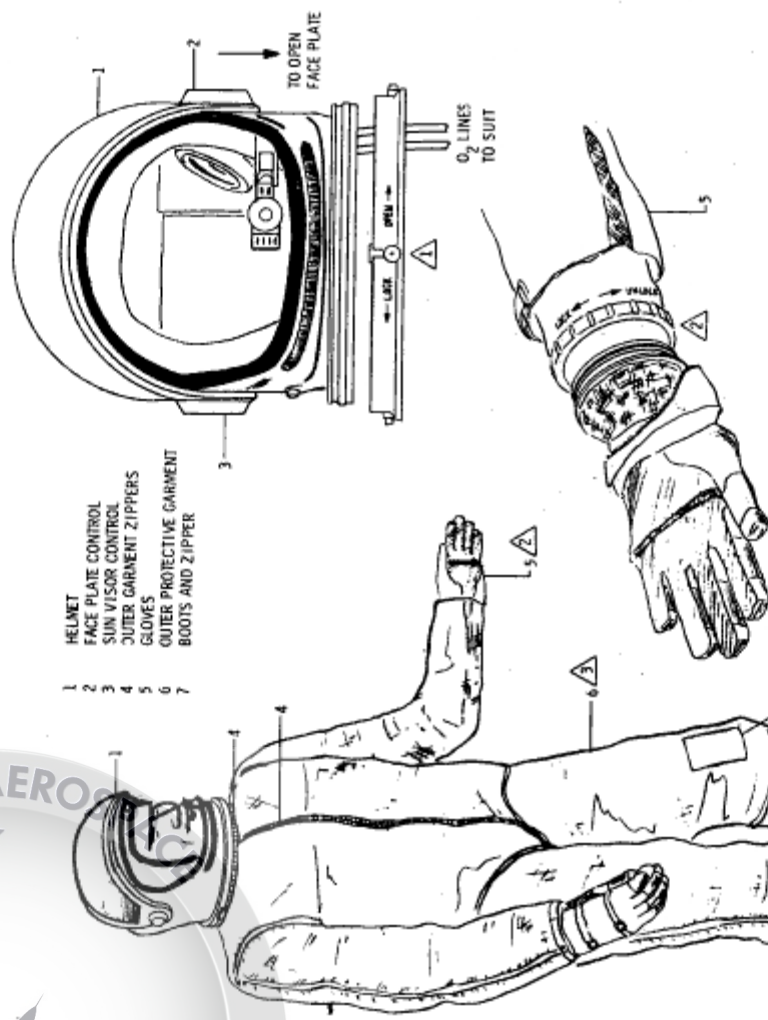
2-16. The following sequence is recommended for normal removal of equipment:

- a. Boots.
- b. Gloves.
- c. Outer Garment.
- d. Helmet.
- e. Suit.

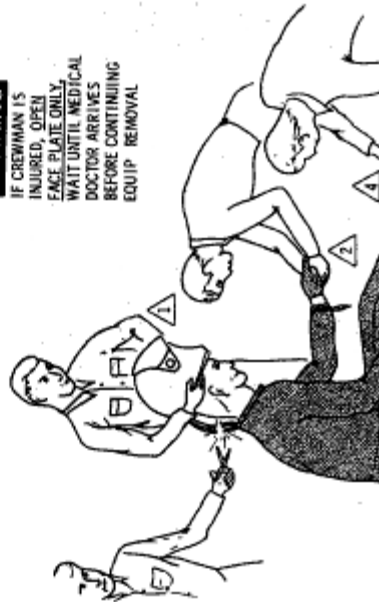
Note



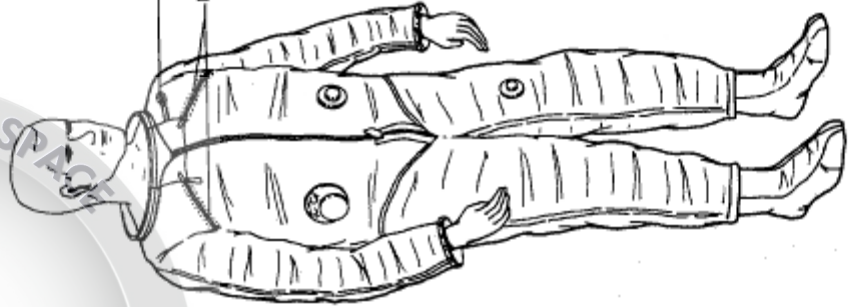
- 1 HELMET
- 2 FACE PLATE CONTROL
- 3 SUN VISOR CONTROL
- 4 OUTER GARMENT ZIPPERS
- 5 GLOVES
- 6 OUTER PROTECTIVE GARMENT
- 7 BOOTS AND ZIPPER



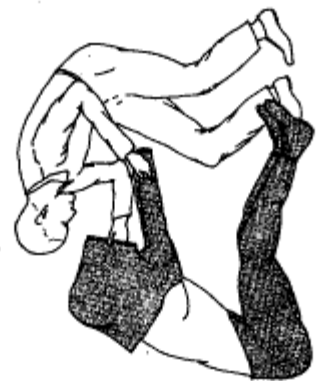
WARNING
 IF CREWMAN IS INJURED, OPEN FACE PLATE ONLY. WAIT UNTIL MEDICAL DOCTOR ARRIVES BEFORE CONTINUING EQUIP. REMOVAL



- ⚠ REMOVE HELMET BY OPERATING RELEASE AND LIFT CLEAR CUTTING O₂ LINES
- ⚠ REMOVE GLOVES BY OPERATING RELEASE AND LIFT CLEAR CUTTING O₂ LINES



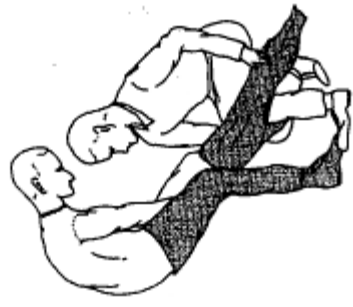
USE RING SAW FOR
EMERGENCY REMOVAL
PRESSURE SUIT ZIPPER LOCATION



DRAW PORTION OF SUIT OVER
CREWMAN'S HEAD



USE ZIPPER TO OPEN PRESSURE SUIT

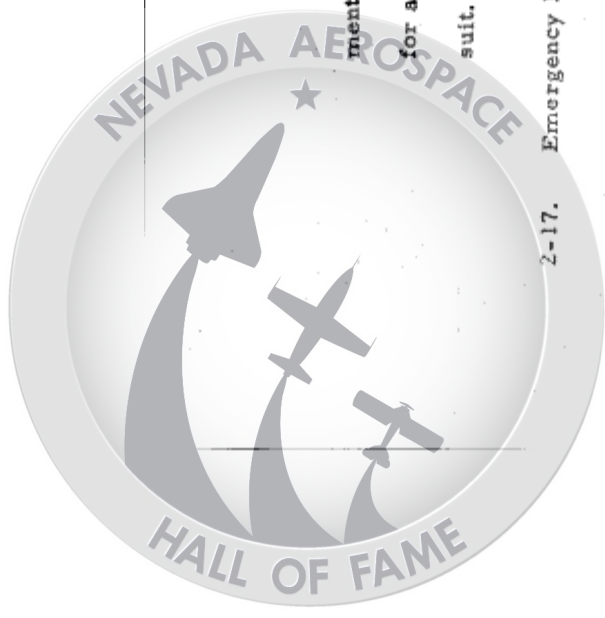


REMOVE SUIT FROM BODY AND LEGS AS SHOWN

CAUTION

PRIOR TO REMOVING PRESSURE
SUIT THE FOLLOWING ITEMS
REQUIRE REMOVAL

1. BOOTS
2. GLOVES



ment zipper and pressure suit main zipper for access to oxygen disconnects inside the suit.

2-17. Emergency Pressure Suit Handling.

WARNING

If crew member is injured, open face plate only until a medical doctor arrives.

- 2-18. In an emergency the pressure suit may be cut off by using the "ring saw" carried in the left leg pocket of the outer garment. This should only be performed upon orders from a medical doctor. (See Figure 2b-3, Sheet 8.)
- a. Remove helmet and gloves.
 - b. Remove handle from end of saw, push saw through suit below neck ring and saw through neck ring on one side.
 - c. Using same procedure repeat on opposite side of neck ring.
 - d. Open main suit zipper; using saw, cut through front of suit between zipper ends. Remove top half of suit.



2-19. Engine Shutdown Procedure. (See Figure 2-3, Sheet 9.)

2-20. Should the emergency condition exist that engines are still developing power, procedures outlined on Figure 2-3, Sheet 9, provide the most practical means, of stopping engines, shutting off oxygen supply and deactivating electrical busses.

2-21. Handling of TEB, Chemical Ignition Fuel During Crash Rescue Procedures. (See Figure 2-4.)

2-22. A chemical ignition system is used in lieu of a more conventional electrical ignition system. Pyrophoric fluid (triethylborane) is contained within tanks, one for each engine located in the nacelle area.

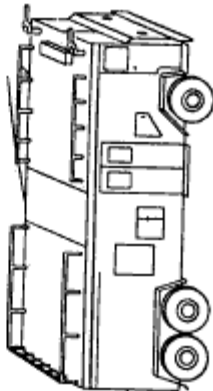
WARNING

Procedures are established in the Flight Manual which require the pilot to dump the chemical fuel during an emergency. There are no restrictions against dumping TEB into a windmilling engine. If this is not possible the condition could become serious. There are no quick opening access panels near the chemical fuel tank and lines. Should

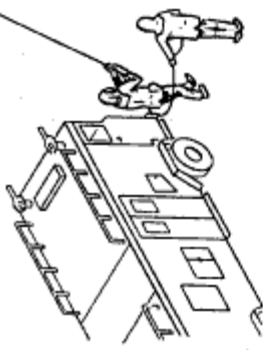


CRASH RESCUE PROCEDURES

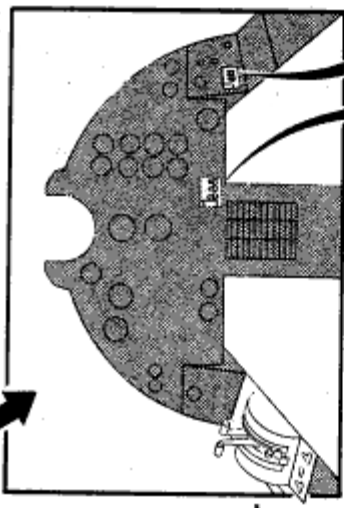
IF ENGINES ARE STILL RUNNING AT HIGH RPM AFTER A CRASH, APPROACH TO COCKPITS IS NOT SAFE BECAUSE OF INTAKE SUCTION HAZARD.



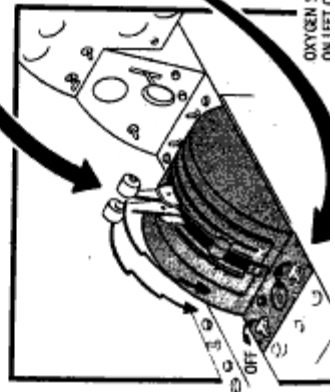
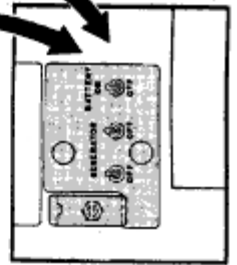
IF CONDITIONS PERMIT, MANEUVER A TRUCK TAIL-GATE FIRST AGAINST THE SIDE OF THE FUSELAGE IN FRONT OF INTAKE TO CUT DOWN SUCTION HAZARD ON MAN WITH LIFE LINE.



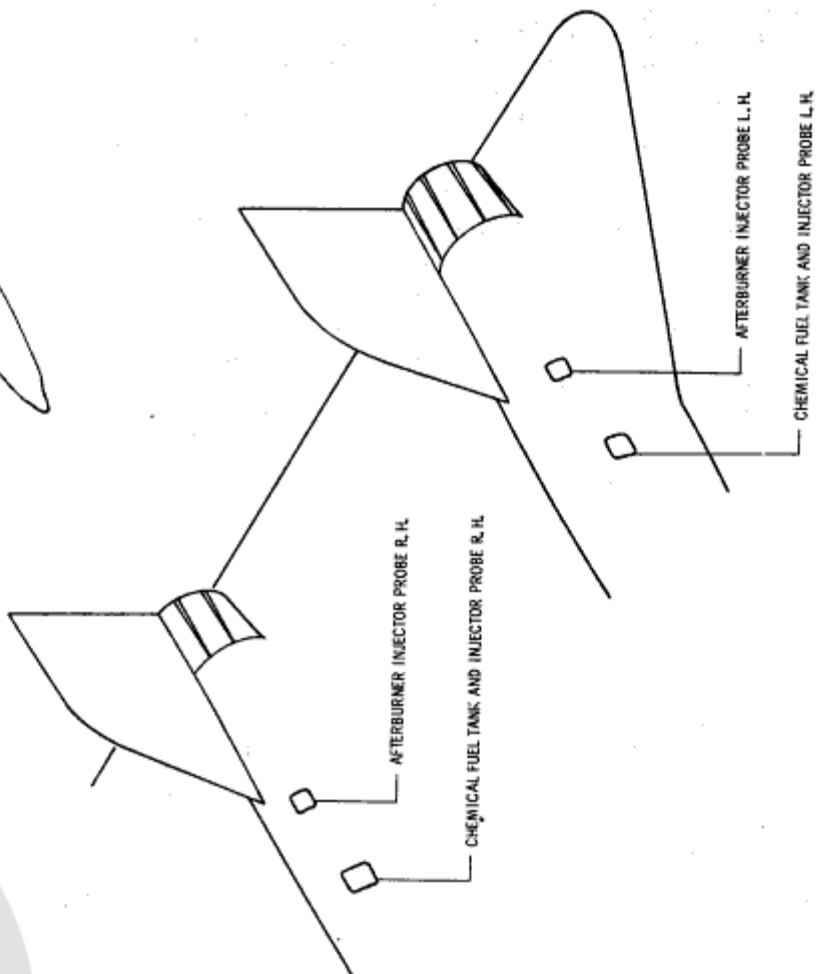
SECURE A LIFE LINE AROUND MAN'S WAIST, ANCHOR IT TO THE CRASH TRUCK, AND APPROACH COCKPIT FROM THE NOSE. OPEN CANOPY AND RETARD THROTTLES, TURN OFF OXYGEN, AND TURN OFF BATTERY.



ALTERNATE SWITCH LOCATION



OXYGEN SWITCHES ARE LOCATED ON LEFT PONDICULE AFT OF BATTERY





A TEB fire be the primary concern, the immediate area about the tank location must be flooded with water or CO₂ until it can be determined that a hazard no longer exists.

2-23. Damage Prevention.

2-24. The following information consists of data and recommended procedures for the extinguishing of aircraft fires.

2-25. Fire and Explosion Hazards.

2-26. Personnel should be familiar with the fire and explosion hazards of this aircraft so that precautionary measures can be taken. Fires and explosions generally occur when a flammable substance, oxygen (air) and a source of ignition are brought together. The primary flammable substances in this aircraft are fuel, hydraulic fluid, lubricating oil and greases and pyrophoric fluid used in the engine ignition system. Pure oxygen can cause a fire or explosion simply by contact with these substances. Common source of ignition are electric arcs, flame and hot surfaces. The following conditions are particularly hazardous:

- a. The mixture of fuel vapor and air in the fuel tanks and vent system is explosive when ignited. However, JP-5 class fuels are



b. Fuel, hydraulic fluid or engine oil spraying in a fine mist will explode or flash when ignited.

c. Fires or explosions can be produced spontaneously when flammable substances contact oxygen of high purity.

d. The pyrophoric fluid (triethylborane) used in the engine ignition system will ignite immediately upon exposure to air.

2-27. Fire Fighting Precautions.

2-28. Personnel should be alert for possible aircraft ground fires and be prepared to act rapidly and effectively if a fire is discovered. It is recommended that all personnel become familiar with the following types of fire hazards and precautions.

a. How access is gained quickly to apply extinguishing agent.

b. How to notify professional fire fighting personnel immediately.

c. The agents that are recommended for different kinds of fires and how to operate extinguishing equipment eg, area water, water fog, CO₂, DCP or chemical and mechanical foams.

d. Chemical and mechanical foam agents leave deposits, if possible these agents should be removed by flushing with water.

CAUTION

with running water and wiping as dry as possible.

The following agents are not approved as fire extinguishing agents. Inadvertent use must be reported to the aircraft recovery team.

- (1). ANSUL MET-L-X Dry Chemical.
- (2). Chlorobromomethane (CBM).
- (3). Soda and acid type extinguishers.

e. Availability and serviceability of all extinguishing equipment required.

2-29. General procedures to be followed when a fire is discovered:

- a. Apply proper agent to fire as soon as possible.
- b. For engine fires, follow procedures as outlined on Figure 2-5.
- c. Position yourself up wind and do not stand in flammable liquids when applying agents.
- d. Move handling equipment away so that fire fighting equipment will not be hampered.
- e. When all available agent is expended and/or fire is out of control, evacuate the area because of the danger of explosion.

2-30. Oxygen Fires.

2-31. Oxygen can cause spontaneous ignition and explosions when it comes in contact with flammable substances. Fires aided by oxygen will burn intensely and spread rapidly, therefore, CO₂ or DCP (dry chemical powder) should be applied to slow the progress of these fires. However,

NEVADA AEROSPACE



HALL OF FAME

Note

The oxygen system may be a liquid or gaseous type.

2-32. Engine Fires. (See Figure 2-5.)

2-33. Engine or nacelle fires may not be indicated by the engine fire and/or overheat system. Personnel should be alert for this condition at all times during engine ground operation.

2-34. Chemical Ignition Fuel (TEB) Fires.

2-35. A fire will occur when triethylborane (TEB) is exposed to air as a result of line rupture or leaks. To control a TEB fire, the fire fighter should attempt to confine the fire by blanketing the burning liquid with foam, water spray or CO₂.

WARNING

Carbon tetrochloride and halogenated hydrocarbons react with TEB and should never be used to combat fires.

Note

Tests have indicated that TEB will ignite when exposed to air at all temperatures to be encountered during handling.

2-36. Hot Aircraft Wheels.

2-37. When an aircraft is subject to excessive braking action, especially

on a maximum brake landing or gear chute failure, the following procedures





FIRE FIGHTING PRECAUTIONS

WARNING PRECAUTIONS LISTED BELOW SHALL BE OBSERVED, IN ORDER TO AVOID SERIOUS INJURY TO INVOLVED PERSONNEL.

- 1 FIGHT FIRE, WHEN POSSIBLE FROM UP-WIND SIDE.
- 2 DO NOT STAND IN FLAMMABLE LIQUIDS.
- 3 DO NOT PUT YOURSELF IN POSITION WHERE YOU CAN BE TRAPPED BY FIRE OR FUMES.
- 4 USE CAUTION TO AVOID SLIPPING ON WET SURFACES.
- 5 USE DRY CHEMICAL POWDER OR CO₂ AGENT IF AVAILABLE.
- 6 IF CO₂ OR OTHER APPROVED LIQUID EXTINGUISHING AGENTS ARE USED, USE EXTREME CARE THAT DIRECT BLAST OF COLD LIQUID OR GAS DOES NOT CONTACT HOT METAL SURFACES. STRESS EXPLOSIONS CAN BE CAUSED WITH RESULTANT INJURY TO PERSONNEL.

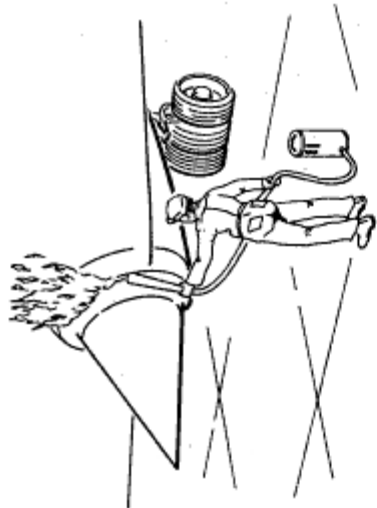
CLEANING PROCEDURE

- AFTER FIRES ARE EXTINGUISHED REMOVE CHEMICAL POWDER FROM AFFECTED AREAS OF AIRCRAFT AS FOLLOWS:
- 1 WIPE AFFECTED AREAS WITH CLEAN CLOTH. USE AIR BLAST TO CLEAN AREAS NOT READILY ACCESSIBLE TO CLOTH WIPING.
 - 2 WASH ALL AFFECTED AREAS THOROUGHLY.
 - 3 RINSE AFFECTED AREAS WITH APPROVED ANTI-RUST SOLUTION AND RINSE WITH CLEAN WATER.
 - 4 THOROUGHLY CLEAN AND INSPECT ALL ENGINE PARTS IN THE AREA WHICH THE CHEMICAL AGENT HAS BEEN INTRODUCED. THIS WILL INCLUDE A THOROUGH ENGINE INSPECTION WHENEVER POWDER WAS INTRODUCED SO THAT IT PASSES THROUGH THE ENGINE.

FIRE IN ENGINE AIR INLET DUCT

THESE FIRES USUALLY OCCUR DURING STARTING OR WHILE ENGINE IS RUNNING. IN CASE OF FIRE PROCEED AS FOLLOWS:

- 1 THROTTLE - ADVANCE PART WAY TO MILITARY POWER.
- NOTE**
- IF FIRE DOES NOT BLOW OUT OR PERSISTS, SHUT DOWN ENGINE AND FIGHT AS OIL FIRE.
- 2 THROTTLE - OFF
- 3 EMERGENCY FUEL SHUT - OFF SWITCH - OFF (GUARD UP), ALLOW 5 SECONDS FOR VALVE TO CLOSE.
- 4 BATTERY SWITCH - OFF.
- 5 LEAVE COCKPIT AS SOON AS POSSIBLE.
- 6 INTRODUCE DRY CHEMICAL POWDER OR CO₂ AGENT INTO THE ENGINE AIR INLET DUCT



FIRE IN ENGINE NACELLE

IF FIRE OCCURS WHILE ENGINE ACCESS DOORS ARE OPEN (AS DURING INITIAL ENGINE RUN), FIRE FIGHTING IS SIMPLIFIED. WHEN ENGINE ACCESS DOORS ARE CLOSED, ENTRY FOR THE EXTINGUISHING AGENT IS THROUGH THE LOWER "SUCK IN" DOORS AT THE ACCESSORY SECTION. IN CASE OF FIRE PROCEED AS FOLLOWS:

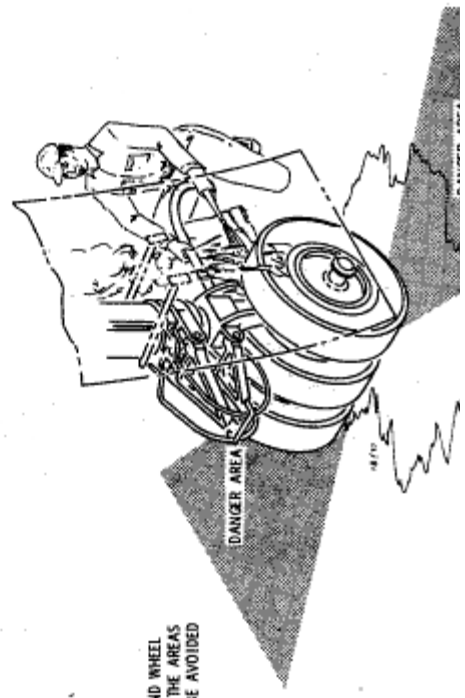
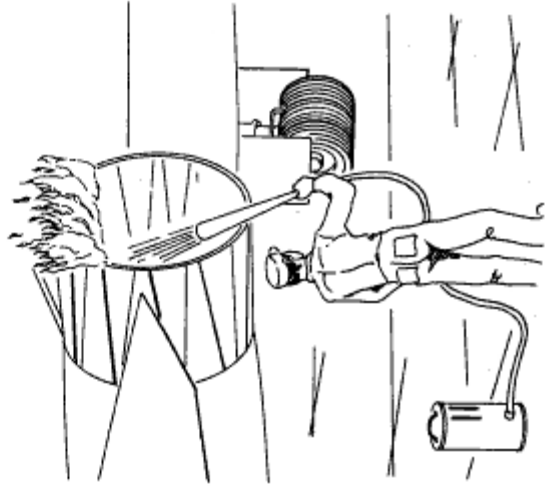
- 1 CHEMICAL IGNITION PURGE SWITCH - DUMP (SWITCH UP).
- CAUTION**
- ACTUATE DUMP SWITCH IMMEDIATELY TO ENSURE HYDRAULIC PRESSURE AND POWER WILL BE AVAILABLE TO DUMP THE CIS TANK. POWER WILL BE REQUIRED FOR UP TO 10 SECONDS.
- 2 THROTTLE - OFF.
- 3 EMERGENCY FUEL SHUTOFF SWITCH-OFF (GUARD UP), ALLOW 5 SECONDS FOR VALVE TO CLOSE.
- 4 BATTERY SWITCH - OFF.





TAIL PIPE FIRES USUALLY RESULT FROM EXCESS FUEL COLLECTING IN THE AFTERBURNER SECTION AFTER SHUT-DOWN, OR DURING STARTING CYCLES. IN CASE OF FIRE (WITH GROUND START UNIT ENGAGED) PROCEED AS FOLLOWS.

- 1 THROTTLE OFF.
- 2 EMERGENCY FUEL SHUT-OFF (GUARD UP).
- 3 IF POSSIBLE MAINTAIN OPERATION UNTIL ALL EVIDENCE OF FIRE HAS DISAPPEARED. IF FIRE DOES NOT BLOW OUT OR PERSISTS DISCONTINUE START OPERATION AND FIGHT AS OIL FIRE BY APPLYING CO₂ IN SHORT BURST INTO AFTERBURNER SECTION.



WARNING

EXCESSIVE BRAKE HEATING WEAKENS TIRE AND WHEEL STRUCTURE AND INCREASES TIRE PRESSURE. THE AREAS INBOARD AND OUTBOARD OF WHEEL SHOULD BE AVOIDED

NOTE

USE WATER, WATER FOG, CO₂ OR DCP, FOR EXTINGUISHING WHEEL BRAKE FIRES.



2-38. Wheel Brake Fires. (See Figure 2-5.)

WARNING

Excessive brake heating tends to weaken tire and wheel structure and increase tire pressure. The area inboard and outboard of the wheel should be avoided.

a. Apply DCP, water or water fog to brake and wheel.

2-39. Health Hazards.

2-40. Liquid Nitrogen.

2-41. Liquid nitrogen is contained in two flasks located within the nose landing gear compartment. Contact with this liquid shall be avoided as direct skin contact can result in extremely painful sores, which resemble burns. Also, symptoms of hypoxia can occur from prolonged contact with escaping GN₂ in confined areas.

2-42. Ammonia.

2-43. Ammonia gas is poisonous in strong concentrations, and can cause severe damage to the tissues of the eyes, nose, throat and lungs. Aqueous ammonia solution is very caustic, and can be damaging to the skin tissue

2-44. Aqua ammonia solution is contained within a compartment located on the right lower fuselage section just forward of the wing leading edge.

2-45. Triethylborane (TEB).

2-46. TEB will cause serious thermal burns upon skin contact. The burned area may provide highly absorbent area for this compound. Therefore, skin contact must be avoided. Inhalation of these compounds is extremely unlikely due to the pyrophoric characteristics. However, the fumes are toxic. Two TEB tanks, one for each engine, contain 600 cc of fluid each when initially serviced. (See Figure 2-4 for tank location.)

2-47. Should personnel contact be made with TEB, a source of reasonably clean water must be used to flush burning fuel from a person. Prevent contamination of the burned area if at all possible. If TEB contacts the eyes, flush immediately with large quantities of water for 15 to 20 minutes or until medical personnel arrive.





SECTION III
GROUND HANDLING

TABLE OF CONTENTS

Paragraph No.	Title	Page
3-1	Ground Handling	3-1
3-3	Aircraft Lifting	3-1
3-8	Emergency Extension of Landing Gear	3-8
3-10	Main Gear Towing	3-10



SECTION III

GROUND HANDLING

LIST OF ILLUSTRATIONS

Figure No.	Title	Page
3-1	Crane Lifting	3-2
3-2	Pneumatic Bag Lifting	3-5
3-3	Emergency Gear Extension	3-9
3-4	Main Gear Towing	3-11



3-1. GROUND HANDLING.

3-2. This section provides the correct handling procedures using available equipment to properly handle the aircraft during emergency conditions. All safety precautions which provide for safe handling of the aircraft shall be strictly adhered to.

3-3. Aircraft Lifting.

WARNING

Ensure that all electrical power is turned off.

CAUTION

Do not climb on or off aircraft, unless necessary.

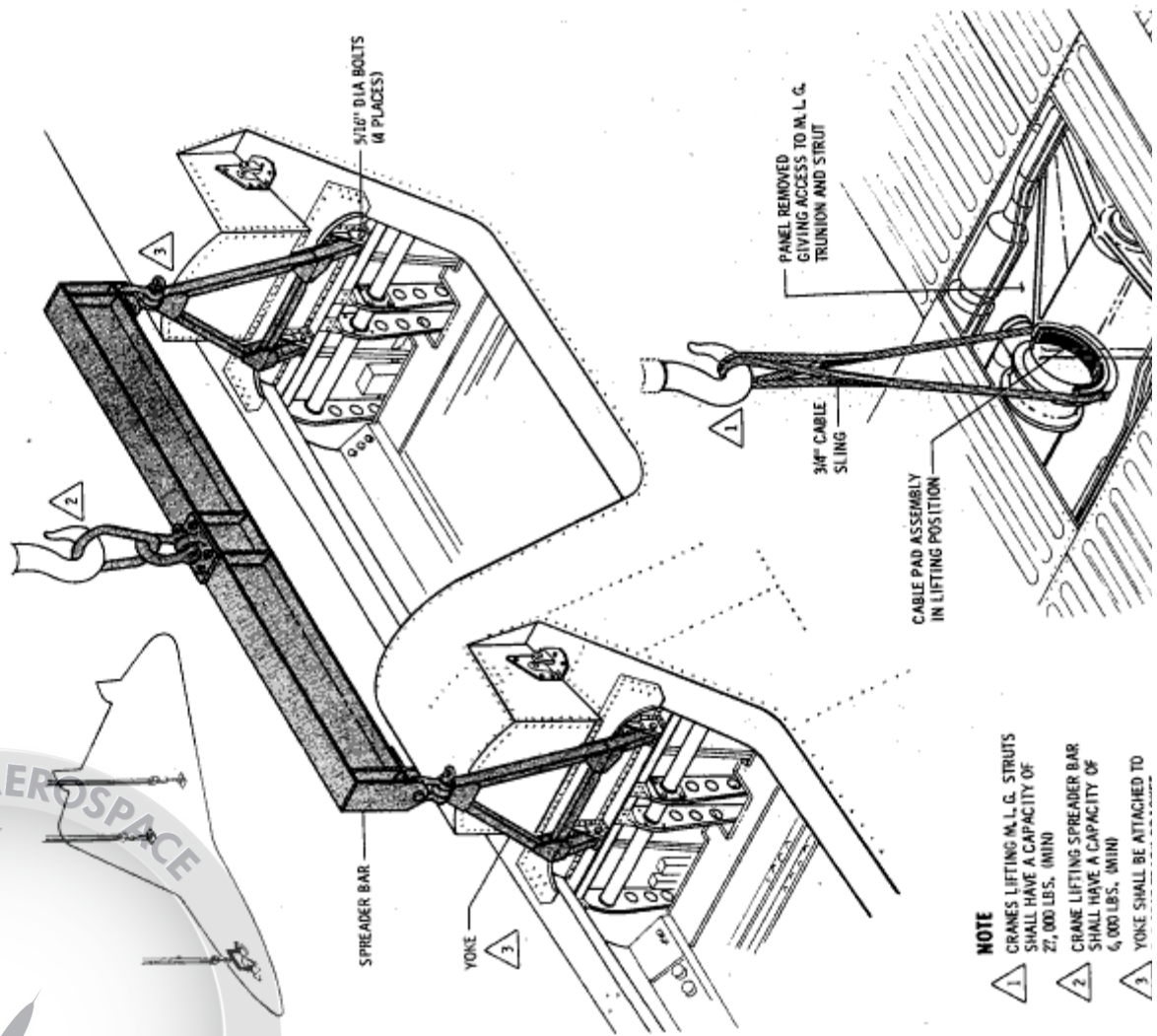
3-4. Crane Lifting. (See Figure 3-1.)

3-5. If the crash site is accessible for a crane using cables, bolts, etc. an aircraft setting on the ground with the landing gear retracted or collapsed may be raised as follows :

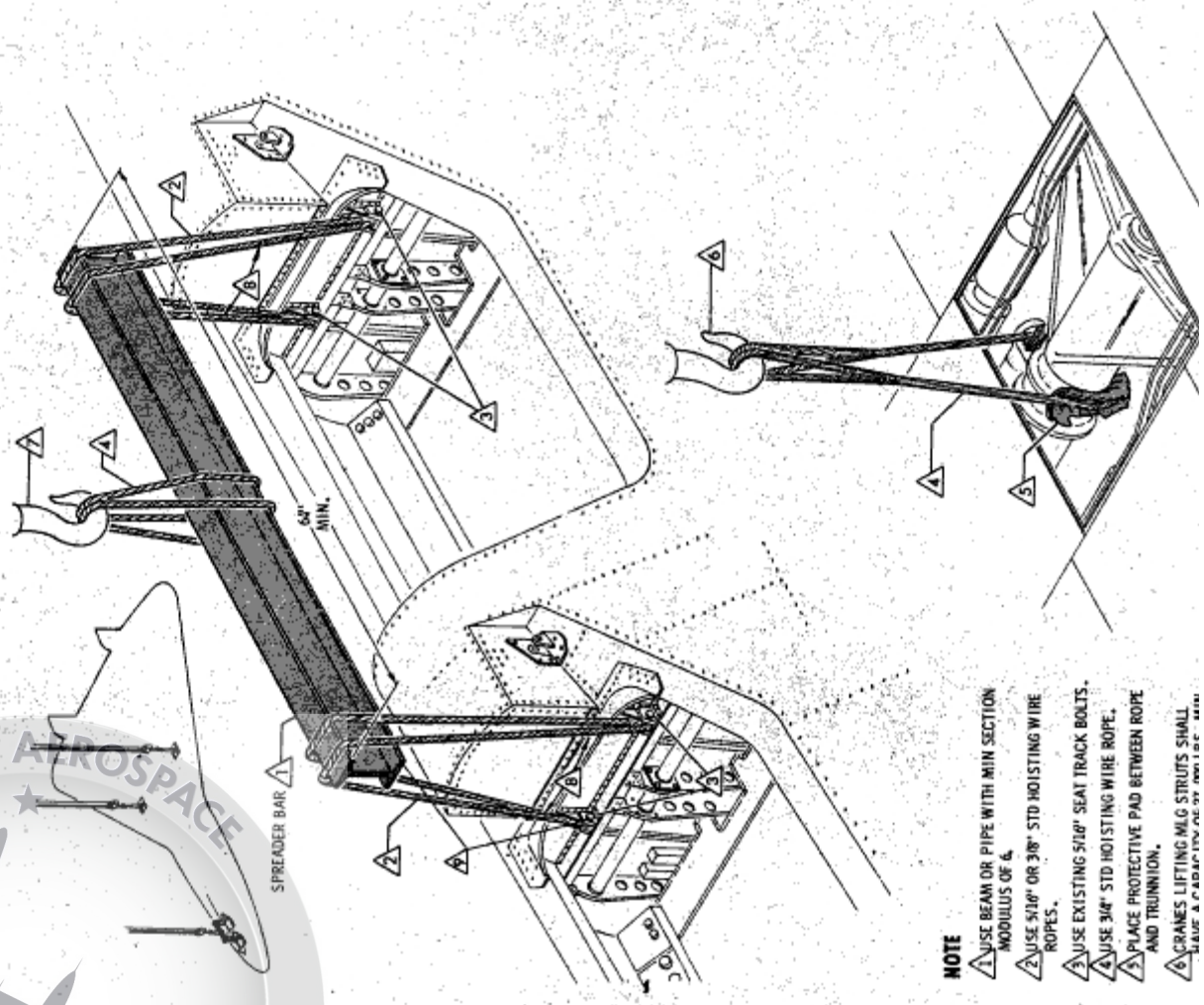
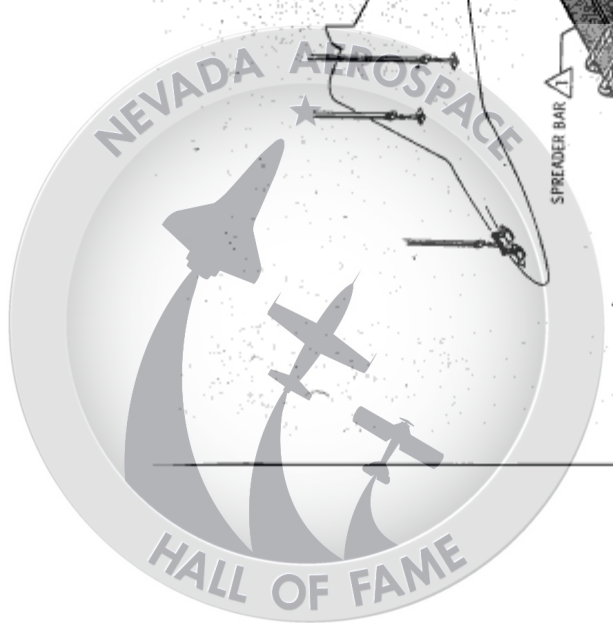
- a. Remove both cockpit seats and seat guide rails.

WARNING

Ensure that all lines and leads to both seats are severed before removing bolts securing seats to



- NOTE**
- 1 CRANES LIFTING M.L.G. STRUTS SHALL HAVE A CAPACITY OF 27,000 LBS. (MIN)
 - 2 CRANE LIFTING SPREADER BAR SHALL HAVE A CAPACITY OF 6,000 LBS. (MIN)
 - 3 YOKE SHALL BE ATTACHED TO



NOTE

- 1. USE BEAM OR PIPE WITH MIN SECTION MODULUS OF 4.
- 2. USE 5/16" OR 3/8" STD HOISTING WIRE ROPES.
- 3. USE EXISTING 5/16" SEAT TRACK BOLTS.
- 4. USE 3/4" STD HOISTING WIRE ROPE.
- 5. PLACE PROTECTIVE PAD BETWEEN ROPE AND TRUNNION.
- 6. CRANES LIFTING MLG STRUTS SHALL HAVE A FABRIC TIE OFF POINT.



b. Figure 3-1 presents a typical spreader bar and "yoke" installation for nose section and a cable attachment to each main landing gear trunion and strut.

c. Cranes and cables lifting the main gear struts must have a capacity of 27,000 pounds minimum each.

d. Cranes, spreader bar and cables lifting at the cockpits seat brackets shall have a capacity of 6,000 pounds minimum.

3-6. Pneumatic Bag Lifting. (See Figure 3-2.)

3-7. If the crash site is inaccessible for a crane, or lifting cables, spreader bars, bolts, etc. are unavailable, the aircraft may be lifted with pneumatic type lifting bag as follows :

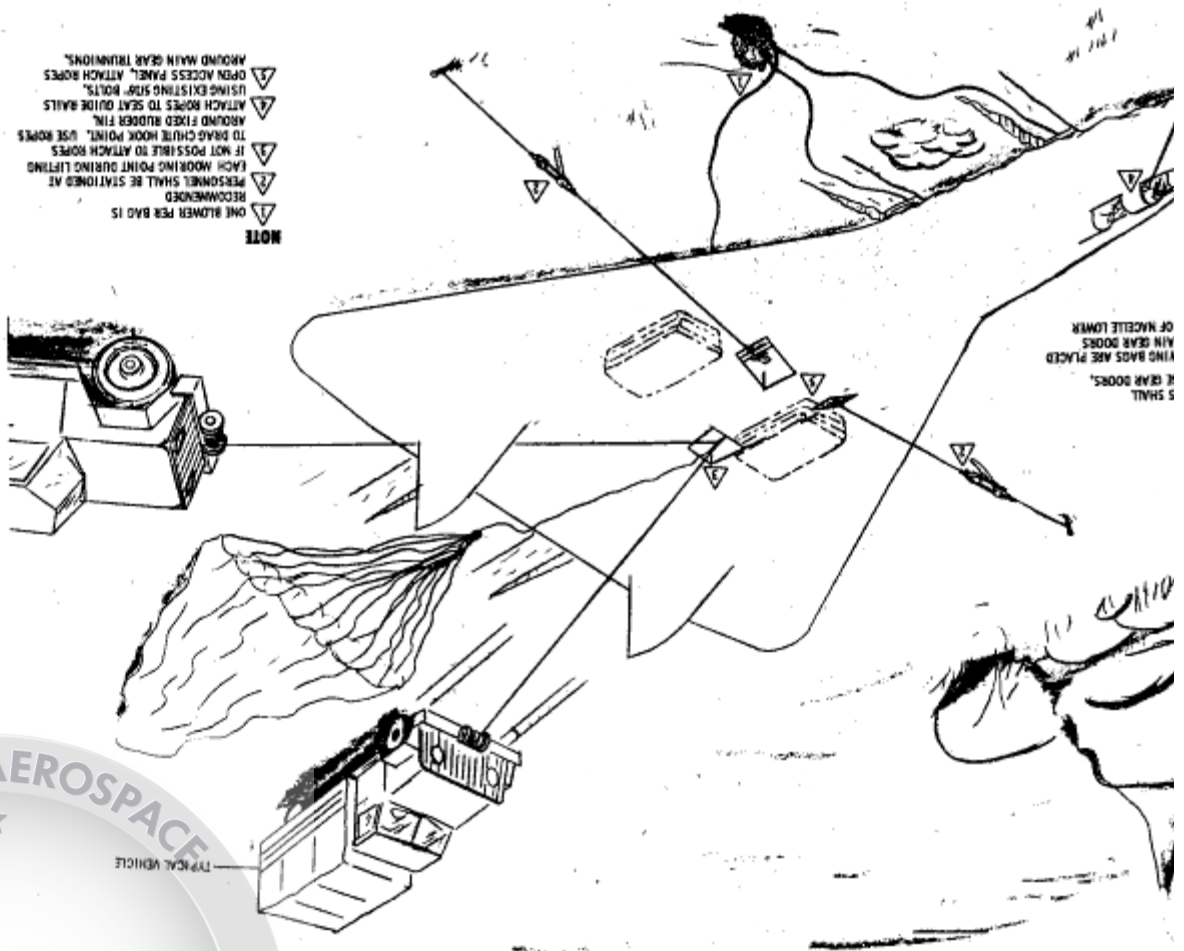
- a. Secure aircraft with block and tackle and ropes to prevent aircraft moving forward, backward or either side while being lifted.

Note

All mooring ropes must be of sufficient length to permit an upward movement of the aircraft without tightening the ropes. If possible, all ropes should have padding or covering at structure con-

- ▽ ONE BLOWER PER BAO IS RECOMMENDED
- ▽ PERSONNEL SHALL BE STATIONED AT EACH MOORING POINT DURING LIFTING
- ▽ IF NOT POSSIBLE TO ATTACH ROPES TO DRAG CHUTE HOOK POINT, USE ROPES AROUND FIXED RUDDER FIN.
- ▽ ATTACH ROPES TO SEAT OUTSIDE RAILS USING EXISTING SHIP BOULTS.
- ▽ OPEN ACCESS PANEL, ATTACH ROPES AROUND MAIN GEAR TRUNNIONS.

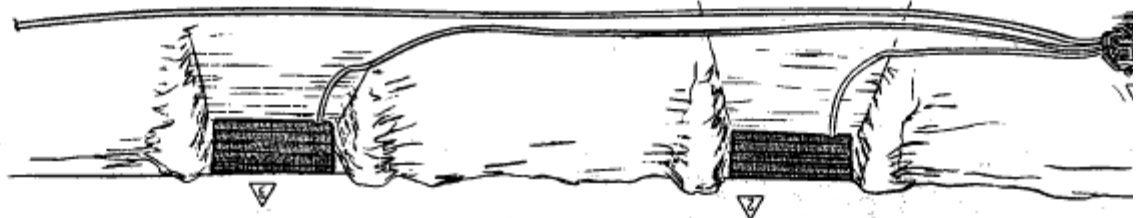
NOTE



5 SHALS
R BAR DOORS,
AND BARS ARE PLACED
OF NACELLE LOWER

TYPICAL VEHICLE



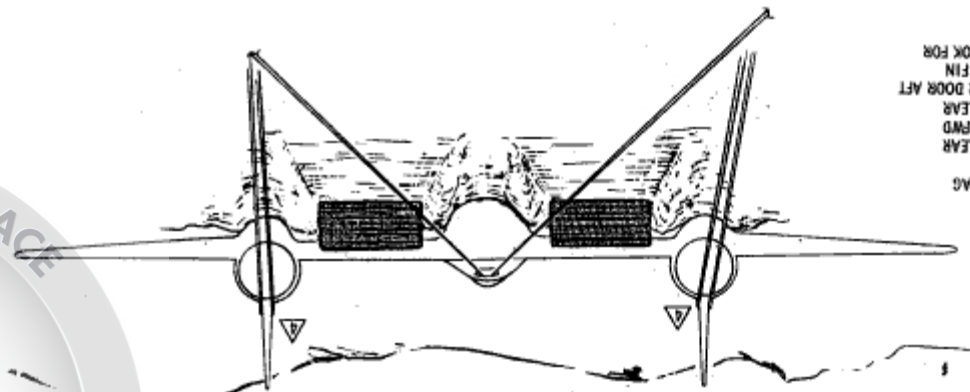



RAISE AIRCRAFT UNTIL FUSELAGE IS APPROXIMATELY 80 INCHES ABOVE TERRAIN. SHORE UP AS NECESSARY.

CAUTION



ER PER BAG
 IDED
 ED TO CLEAR
 ED TO CLEAR
 I DOORS FWD
 ED TO CLEAR
 YLINDER DOOR AFT
 RUDDER FIN
 HUTE HOOK FOR
 ING



- 
- The logo for the Nevada Aerospace Hall of Fame is circular. It features a stylized aircraft in flight, with a smaller aircraft below it. The text "NEVADA AEROSPACE" is written along the top inner edge of the circle, and "HALL OF FAME" is written along the bottom inner edge. A small star is positioned between the two text elements.
- b. If aircraft is in soft terrain it may be necessary to dig out under nacelles and fuselage in order to place lifting bags in position.
- c. Spread a tarpulin under each lift point where bags will be placed.
- d. Position a lift bag on each tarpulin.

Note

Prior to positioning bag, check underside of aircraft for sharp projections that may damage bag.

If any sharp or rough projections are found, place pads between bags and structure to prevent damage to bag.

- e. Connect hoses to inlet connection of bag and outlet connection of engine driven blower(s). Blower(s) should deliver 40 cu. ft. per minute.

CAUTION

Before starting blower(s), check all mooring ropes to ensure bags are located for greatest surface contact between bag and structure.

- f. Inflate all bags simultaneously, unless terrain is such that this would cause aircraft to shift. As bags are inflated, aircraft mooring

CAUTION

Keep enough tension on mooring ropes to prevent aircraft from shifting.

g. When aircraft has reached sufficient height, support the aircraft on its main gear. Each bag should lift 24,000 pounds, 1 to 6 feet at 5 psi.

CAUTION

Do not attempt to support aircraft for too long a time. Bags do not have adequate pressure-holding qualities to permit them to be used as permanent supports.

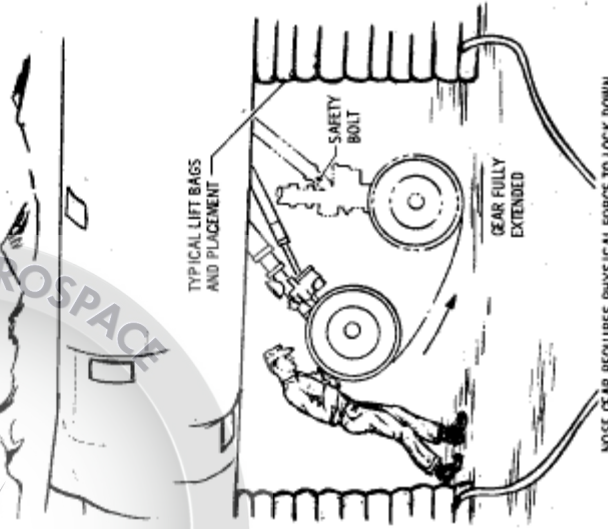
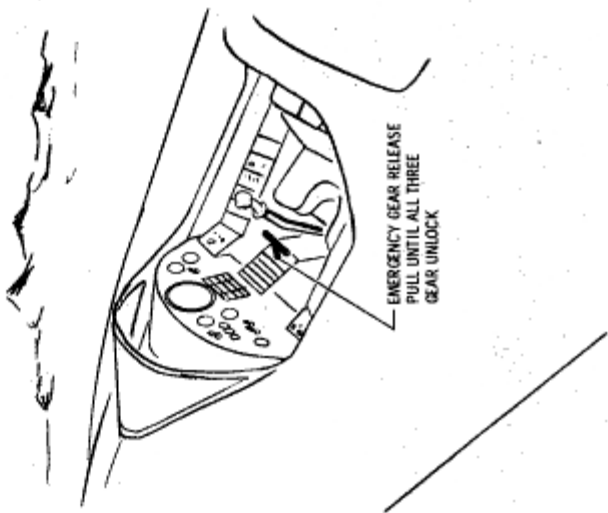
h. When aircraft is adequately supported, remove bags, pads, tarpulins and mooring ropes.


3-8. Emergency Extension of Landing Gear. (See Figure 3-3.)

3-9. Once the aircraft has been raised to gear extension height plus approximately six inches above terrain, the following procedures shall be followed to extend the landing gear:

CAUTION





- 
- The logo for the Nevada Aerospace Hall of Fame is circular. It features a stylized aircraft in flight, a satellite in orbit, and a rocket launch. The text "NEVADA AEROSPACE" is arched across the top, and "HALL OF FAME" is arched across the bottom. A small star is positioned between the top and bottom text.
- a. Pull "T" handle, located on pedestal at pilot's cockpit, to break all three gear out of the up and locked position.
 - b. Both main gear should free fall and lock down within a few seconds without any physical force applied. However, should the main gear not lock down apply force at the axle to complete the down and locked procedure.

- c. The nose gear will unlock and extend partially, apply force to the nose gear to complete the down and locked procedure.

- d. Install bolts at each gear lock location and secure with lock wire or rope.

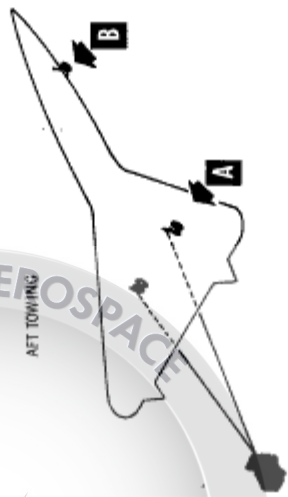
3-10. Main Gear Towing. (See Figure 3-4.)

3-11. When towing forward from the main gear wheels, under emergency conditions, the following procedure shall be used :

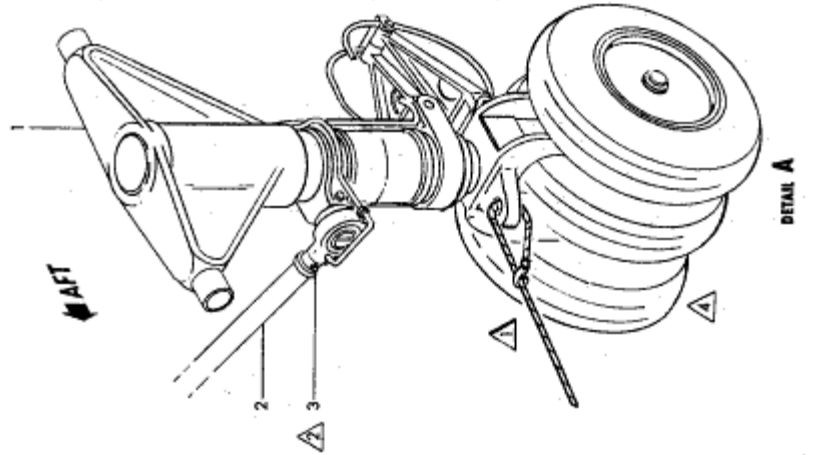
WARNING

Ensure that each main gear has a bolt installed at each gear lock location.

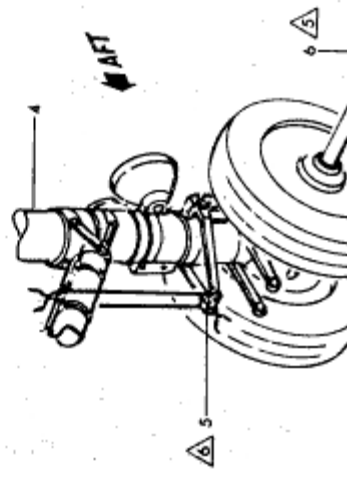
CAUTION



- 1 MAIN GEAR ASSEMBLY
- 2 ACTUATING CYLINDER
- 3 GEAR SAFETY BOLTS
- 4 NOSE GEAR
- 5 UPPER SCISSORS TIED
- 6 FOOT BAR

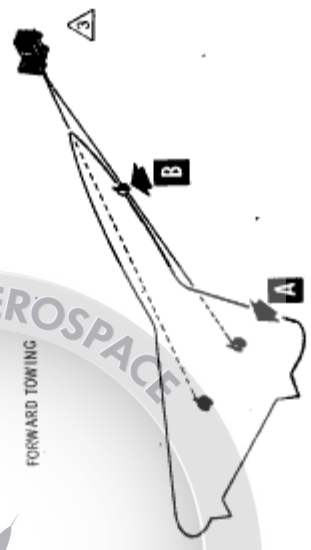


- NOTE**
- 1 USE 3/8" STANDARD WIRE ROPE 90 TO 100 FEET LONG.
 - 2 GEAR SAFETY BOLTS SHALL BE INSTALLED WHEN TOWING AIRCRAFT.
 - 3 TOW VEHICLE SHOULD BE 6 TO 8 FEET AFT OF FUSELAGE TIP.
 - 4 DO NOT USE BLOCKS TO STOP AIRCRAFT DURING AFT TOWING.
 - 5 A 6 FOOT BAR INSERTED IN AXLE OF NOSE GEAR MAY BE USED TO TURN AIRCRAFT.
 - 6 SCISSORS TO BE DISCONNECTED. TIE UPPER SCISSORS WITH ANYTHING USABLE.





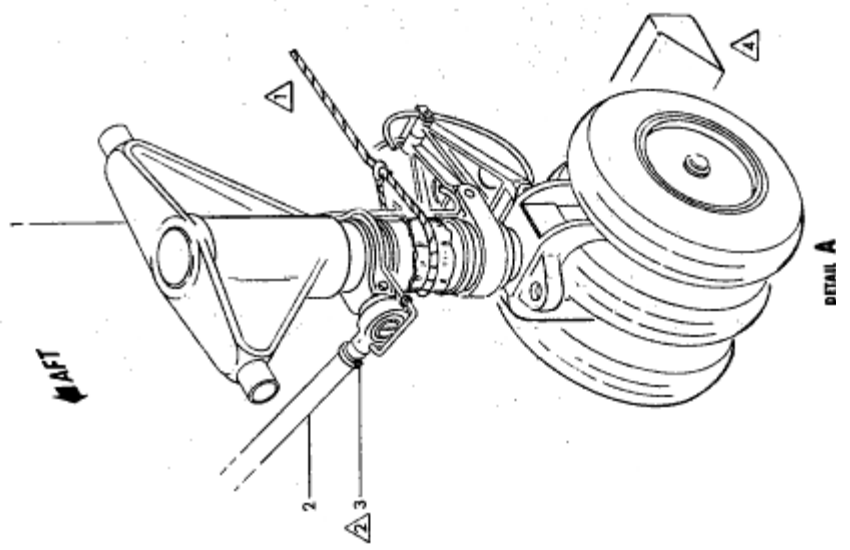
FORWARD TOWING



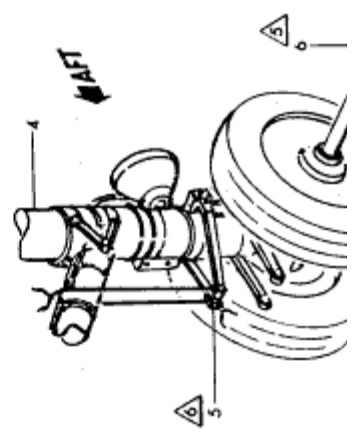
- 1 MAIN GEAR ASSEMBLY
- 2 ACTUATING CYLINDER
- 3 GEAR SAFETY BOLTS
- 4 NOSE GEAR
- 5 UPPER SCISSORS TIED
- 6 FOOT BAR

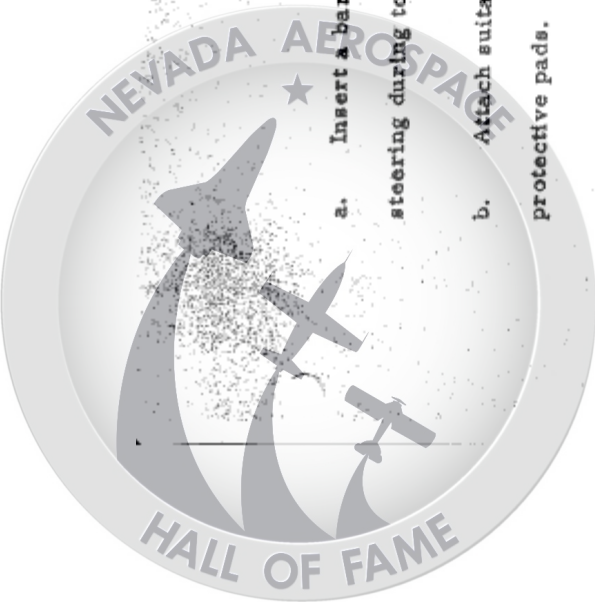
NOTE

- 1 USE 3/8" STANDARD WIRE ROPE 140 TO 170 FEET LONG.
- 2 GEAR SAFETY BOLTS SHALL BE INSTALLED WHEN TOWING AIRCRAFT.
- 3 TOW VEHICLE SHOULD BE 6 TO 8 FEET FORWARD OF NOSE.
- 4 BLOCKS MAY BE USED TO STOP AIRCRAFT.
- 5 A 6 FOOT BAR INSERTED IN AXLE OF NOSE GEAR MAY BE USED TO TURN AIRCRAFT.
- 6 SCISSORS TO BE DISCONNECTED, THE UPPER SCISSORS WITH ANYTHING USABLE.



DETAIL A





- a. Insert a bar of sufficient length into the nose gear axle to permit steering during towing.
- b. Attach suitable cables or ropes around main gear struts with protective pads.

c. Connect cables or ropes to a tractor.

Note

Two tractors may be used, one pulling on each gear.

- d. Pickup the load with the tractor(s) as smoothly as possible in order to keep dynamic loads at a minimum.

CAUTION

One man shall be stationed at each gear location with a suitable block. The aircraft has no parking brake and blocks may be used as stopping devices.

3-12. When towing aft from the main gear wheels, under emergency conditions, the following procedure shall be used:

- a. Attach suitable cables or ropes around main gear struts with pro-



b. Connect cables or ropes to a tractor.

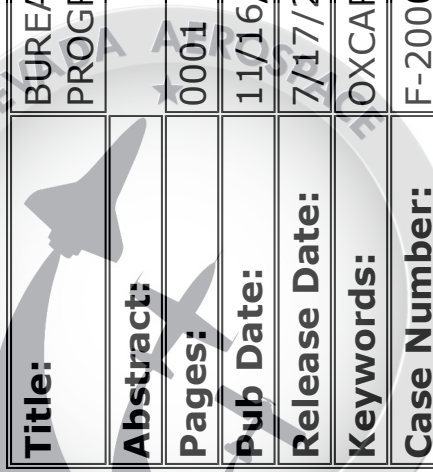
Note

Two tractors may be used, one pulling on each gear.

c. Pickup the load with the tractor(s) as smoothly as possible in order to keep dynamic loads at a minimum.

CAUTION

Blocks shall not be used as stopping devices when towing in the aft direction, unless absolutely necessary to prevent further damage.



Title:	BUREAU OF THE BUDGET RECOMMENDATIONS FOR THE OXCART PROGRAM.
Abstract:	
Pages:	0001
Pub Date:	11/16/1965
Release Date:	7/17/2001
Keywords:	OX CART SR-71 BLACKBIRD BLACK SHIELD A-12
Case Number:	F-2000-01388
Copyright:	0
Release Decision:	RIFPUB
Classification:	U

~~SECRET~~
OXCART

16 November 1965

BRIEFING NOTE FOR THE DIRECTOR OF CENTRAL INTELLIGENCE

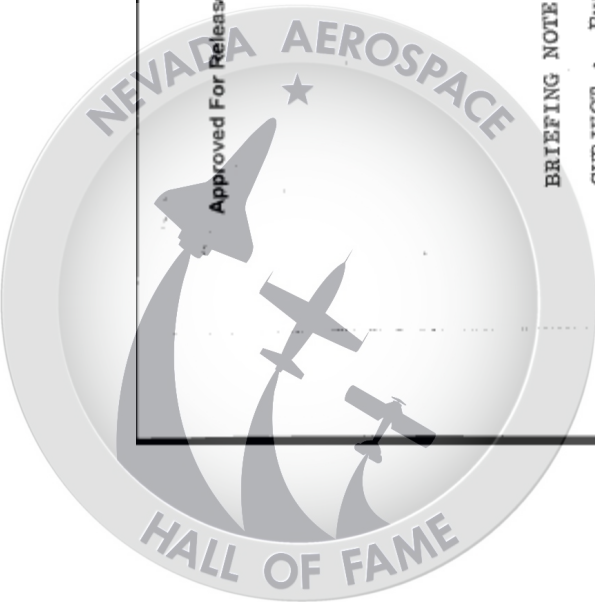
SUBJECT : Bureau of the Budget Recommendations for the OXCART Program.

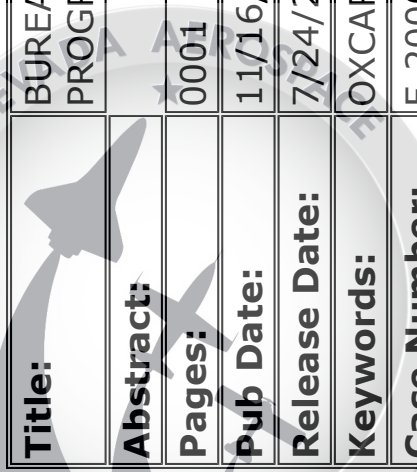
1. The attached pages contain comments on the assumptions made in Mr. Thomas' recommendations to the Director of the Budget to eliminate the OXCART program. The comments are in the areas of policy, technology, operations and security.

2. There is a point of paramount importance, however, which should be made prior to a discussion of Mr. Thomas' assumptions. Mr. Thomas' recommendation to eliminate the OXCART program is to deny the United States Government a non-military capability to conduct aerial reconnaissance of denied areas in the world in the years ahead.

JACK C. LEDFORD
Brigadier General, USAF
Director
(Special Activities)

OXCART





Title:	BUREAU OF THE BUDGET RECOMMENDATIONS FOR THE OXCART PROGRAM.
Abstract:	
Pages:	0001
Pub Date:	11/16/1965
Release Date:	7/24/2001
Keywords:	OX CART SR-71 BLACKBIRD BLACK SHIELD A-12
Case Number:	F-2000-01388
Copyright:	0
Release Decision:	RIFPUB
Classification:	U

~~SECRET~~
OXCART

16 November 1965

BRIEFING NOTE FOR THE DIRECTOR OF CENTRAL INTELLIGENCE

SUBJECT : Bureau of the Budget Recommendations for the OXCART Program.

1. The attached pages contain comments on the assumptions made in Mr. Thomas' recommendations to the Director of the Budget to eliminate the OXCART program. The comments are in the areas of policy, technology, operations and security.
2. There is a point of paramount importance, however, which should be made prior to a discussion of Mr. Thomas' assumptions. Mr. Thomas' recommendation to eliminate the OXCART program is to deny the United States Government a non-military capability to conduct aerial reconnaissance of denied areas in the world in the years ahead.

JACK C. LEDFORD
Brigadier General, USAF
Director
(Special Activities)

OXCART



Title:	SNIE 10-2-66-REACTIONS TO A POSSIBLE US COURSE OF ACTION
Abstract:	
Pages:	0008
Pub Date:	3/17/1966
Release Date:	1/18/2005
Keywords:	SOUTH VIETNAM FREE WORLD US CHINA VIETNAM LAOS COMMUNIST MILITARY
Case Number:	DS-2004-00003
Copyright:	0
Release Decision:	RIPPUB
Classification:	U

~~TOP SECRET~~

[Redacted]

[Redacted]

SNIE 10-2-66

17 March 1966

Copy No. 43

SPECIAL NATIONAL INTELLIGENCE ESTIMATE

Number 10-2-66

REACTIONS TO A POSSIBLE US COURSE OF ACTION

Submitted by

M. Kaban

DIRECTOR OF CENTRAL INTELLIGENCE

Concurred in by the

UNITED STATES INTELLIGENCE BOARD

As indicated overleaf

17 March 1966

DATE

[Redacted]

Authenticated:

James D. Taylor

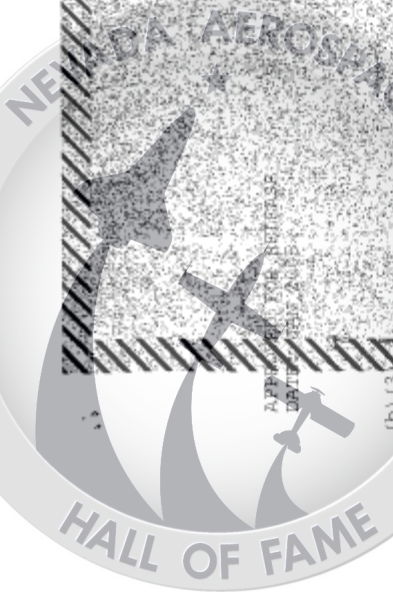
EXECUTIVE SECRETARY USIB

[Redacted]

[Redacted]

~~WARNING~~

~~The sensitivity of this document requires that it be handled with maximum security precautions on a need-to-know basis. Recipients will insure that only personnel with proper clearance and~~



Submitted by the

DIRECTOR OF CENTRAL INTELLIGENCE

The following intelligence organizations participated in the preparation of this estimate. The Central Intelligence Agency and the intelligence organizations of the Departments of State, Defense, AEC and the NSA.

Concurred in by the

UNITED STATES INTELLIGENCE BOARD

On 17 March 1966, Concurring were the Director of Intelligence and Research, Department of State, the Director, Defense Intelligence Agency, the Assistant General Manager for Administration, Atomic Energy Commission, and the Director of the National Security Agency. The Assistant to the Director, Federal Bureau of Investigation, abstained, the subject being outside of his jurisdiction.

**CLASSIFICATION OF TITLE IS OFFICIAL USE ONLY
WHEN USED SEPARATELY**

~~GROUP 1
EXCLUDED FROM AUTOMATIC
DOWNGRADING AND
DECLASSIFICATION~~

WARNING

~~This material contains information affecting the National Defense of the United States within the meaning of the espionage laws, Title 18, USC, Secs. 793 and 794, the transmission or revelation of which in any manner to an unauthorized person is prohibited.~~

NEVADA



HALL OF FAME

~~TOP SECRET~~

[Redacted]

CENTRAL INTELLIGENCE AGENCY

17 March 1966

SUBJECT: SMIE 10-2-66: REACTIONS TO A POSSIBLE US COURSE OF ACTION

THE PROBLEM

To assess the principal reactions in Communist and non-Communist countries to reconnaissance over China and North Vietnam by OXCART vehicles based in Okinawa.

DISCUSSION

1. China. We believe that the Chinese would quickly acquire knowledge of the operation. Mission aircraft would almost certainly be detected by Chinese radar and, by virtue of speed and altitude, be identified as the new and advanced type of aircraft announced by the President in 1964. The chances are good that Chinese agents on Okinawa would become aware of the operation and that Peiping would quickly relate the new overflights to the base at Kadana.



~~TOP SECRET~~

2. The Chinese would of course try to destroy the aircraft. Assuming their failure to do so, and given their practice of not acknowledging successful U-2 overflights, they would probably not draw any special attention to this operation. Furthermore, in this contingency the kind of pressure they might try to apply to Japan or to any other country which might have afforded assistance would be of the most general sort -- if any at all.

3. The situation would be quite different if an OXCART aircraft came down on Chinese territory. Such an incident would be the occasion for a major political and propaganda campaign, particularly if a live American pilot fell into Chinese hands. In dramatizing the affair, Peiping would hope to persuade the world, including the American public, of Chinese strength and of the reckless aggressiveness of US policy. They would also use what resources they had to mobilize public opinion in Japan and in Okinawa against US control of the latter island and against the existence of US bases in Japan itself.

4. It remains to consider how the Chinese Communists would interpret US intentions in the light of this overflight. The Chinese reactions would be related to the presence of large US ground forces in South



~~TOP SECRET~~



Vietnam, US bombing of North Vietnam, and apprehensions regarding the possibility of a US attack on China itself. The Chinese, in their propaganda, have been stressing the danger of such an attack. Although they may indeed fear a series of actions and reactions in Vietnam and elsewhere which would lead in time to a Sino-US war, they probably do not expect it to occur at an early date. Their apprehensions regarding the likelihood of a US attack on China may grow or diminish depending upon developments between now and the time the overflights begin.

5. Upon detecting OXCART intrusions, there is some chance that Peiping would conclude that the US, in unveiling an advanced system at this time, was seeking target intelligence which it meant to use at an early date. This chance would be greater if the program began intensively, with a large number of overflights in a short period, or if it began concurrently with a major expansion of US air attacks upon North Vietnam.* On the other hand, the Chinese have become accustomed to frequent probes of their air space by different vehicles, and they are aware that improvements in their own defenses have increased the vulnerability of older US

* Mr. Thomas L. Hughes, the Director of Intelligence and Research, Department of State, and Dr. Louis W. Tordella, for the Director, National Security Agency, believe the following sentence should be inserted at this point: "In any case the US employment of such a sophisticated reconnaissance vehicle would tend to increase Chinese fears that the US was expecting an eventual escalation of the Vietnam conflict into open conflict with China."

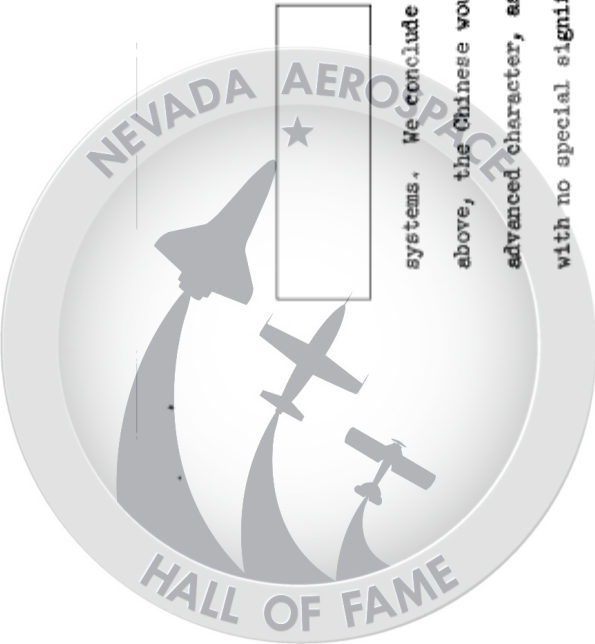


~~TOP SECRET~~

systems. We conclude that, barring the special circumstances mentioned above, the Chinese would soon come to regard this vehicle, despite its advanced character, as another stage in a continuing US collection program, with no special significance for broader US intentions. Thus we think that these missions would not lead them to take any drastic new military action.

6. North Vietnam. The DRV is already subjected to heavy US air attack and reconnaissance. It would attach little extra significance to the OXCART operation.

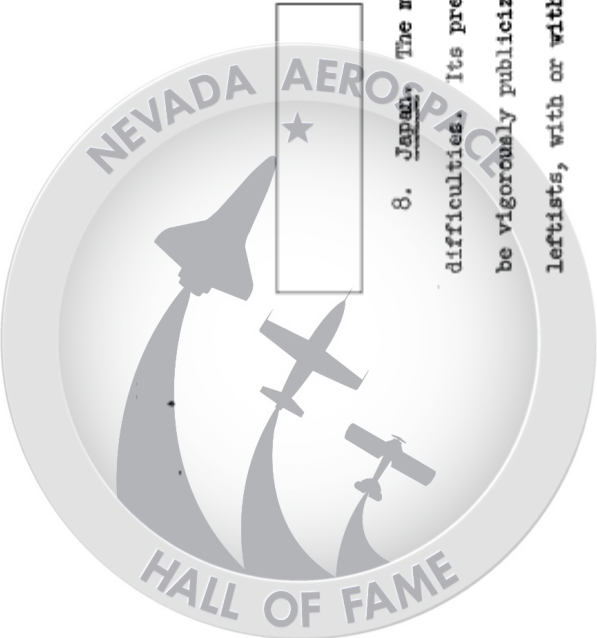
7. The USSR. Through a variety of its own sources -- agents, satellite photography, intercepted communications, and possibly radar returns -- the Soviets would quickly acquire a fairly complete picture of the operation. They would probably reinforce any Chinese or North Vietnamese propaganda campaigns built around the downing of an aircraft. Their primary concern in this regard would be to forestall use of the aircraft over their own territory. They might make private communications to the US stressing the seriousness with which they would view any intrusion into Soviet airspace, but they would almost certainly not make US overflights of China the occasion of a major crisis in US-Soviet relations.



~~TOP SECRET~~

8. Japan. The mere deployment of the aircraft could create difficulties. Its presence on Okinawa would soon become known and might be vigorously publicized by Japanese or American newspapers. Japanese leftists, with or without inspiration from the Chinese Communists, would try to make an issue of it, probably portraying the aircraft as a highly-advanced, nuclear-capable weapon. They would probably try to raise fears that this US activity would lead to Japanese involvement in the Vietnam war or in actions directly against Communist China. We believe that Sato, assuming that the development did not come as a complete surprise to him, could probably deal with the situation, and that he would not raise objections to a continuance of OMCANT operations. If an aircraft came down in China, however, and the Chinese Communists extensively publicized the event, the difficulties of the Japanese government would be greater. We still believe that Sato could probably weather the storm, though he might have to ask the US to discontinue the program from the Okinawa base.

9. Other Non-Communist Reactions. In other non-Communist countries some elements would try to make an issue out of the deployment of the aircraft to the Far East. There would be some fairly vociferous criticism, but most governments would ignore or play down the matter. The situation would be considerably more agitated if an aircraft came down in China,



~~TOP SECRET~~

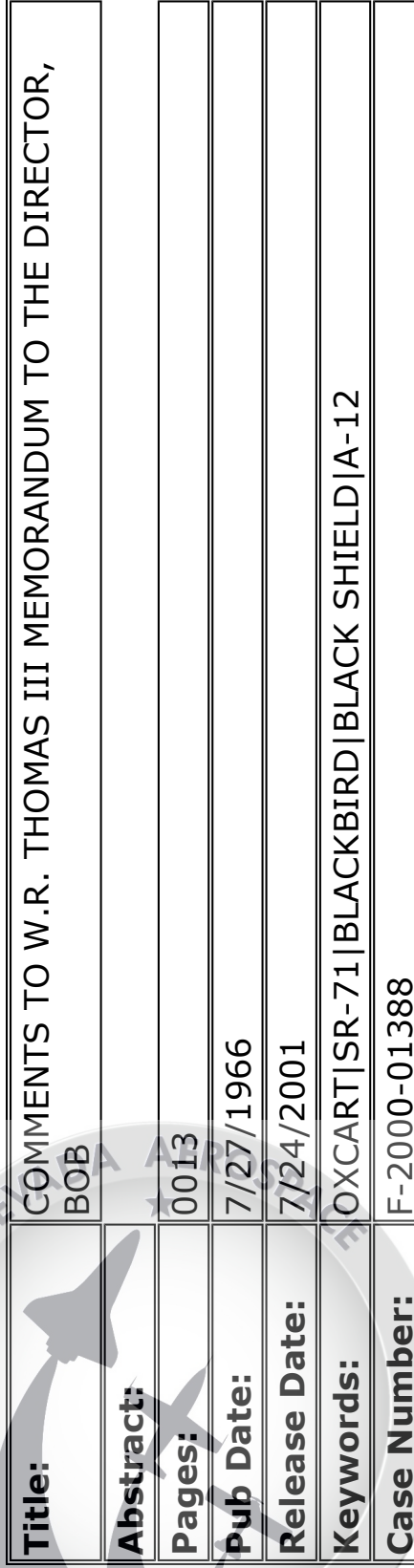


and numerous people, especially perhaps in the US itself, would urge the President to discontinue the operation lest it increase the risk of Chinese Communist overt intervention in the Vietnam war. Even so, there would in our opinion be nothing approaching the outcry over the U-2 affair in 1960, which was used to disrupt a summit conference. There is no developing detente between the US and Communist China to be disturbed by the event, and we have estimated above that the USSR would almost certainly not create a major crisis over the matter. Few foreign governments, whether or not they actually approved the US reconnaissance effort, would be unhappy that it was going on. In such circumstances adverse reactions and pressures on the US are unlikely to be very powerful.

NEVADA AEROSPACE



HALL OF FAME



Title:	COMMENTS TO W.R. THOMAS III MEMORANDUM TO THE DIRECTOR, BOB
Abstract:	
Pages:	0013
Pub Date:	7/27/1966
Release Date:	7/24/2001
Keywords:	OX CART SR-71 BLACKBIRD BLACK SHIELD A-12
Case Number:	F-2000-01388
Copyright:	0
Release Decision:	RIFPUB
Classification:	U

82

DRAFT

DRAFT

27 July 1966

MEMORANDUM FOR : Director of Special Activities

SUBJECT : Comments to W.R. Thomas III Memorandum to the Director, BOB

1. That time of the year approaches when we must take up the cudgels and do battle with Mr. Thomas over whether the OXCART program shall continue or be smothered for lack of funds. Since it can be said safely that Mr. Thomas will most likely carry into the fray the same attitude towards the OXCART program that he had last year, it behooves us to be prepared for his attack this year. Assuming his attitude remains unchanged and not knowing what tack he will take this year, our best preparation is to closely examine his memorandum of 10 November 1965 for errors in fact and rationale. Thus armed we will be in a better position to meet his assault on the OXCART program's existence.

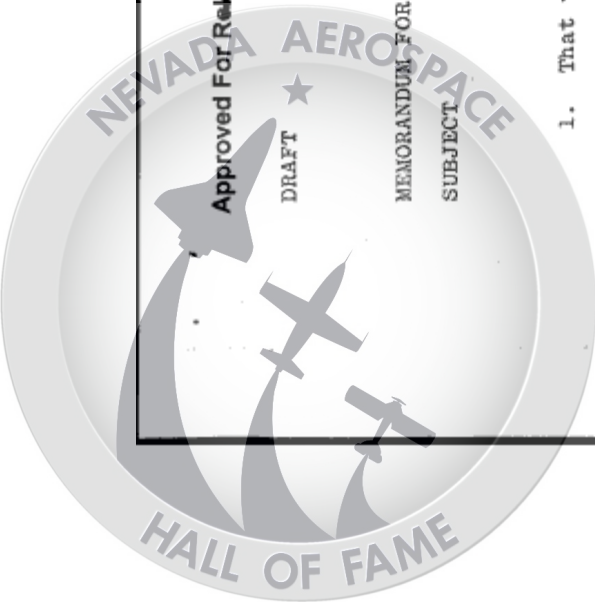
2. Since the Thomas memorandum is somewhat disjointedly organized, all comments will be arranged in the same sequence.

(Lines 1-6) In his opening paragraph Mr. Thomas states that the



25X1A

state his figure includes the YF-12A and its fire control and missile hardware: the TAGBOARD program with its expensive



modification costs for two mother ships and the purchase of 20 drones and all the sensor procurement for the OXCART, 25X1D SR-71 and TAGEBOARD programs.

(Lines 20-32) In comparing the flight capabilities of the SR-71 and the OXCART vehicle Mr. Thomas does not tell the whole story.

What the paper in question seems to avoid is the demonstrated fact that the A-12 is an operational, proven system in being. The statement that the SR-71 will suddenly achieve operational readiness in July 1966 was highly assumptive and, in fact, not achieved. As indicated by Mr. Thomas, the SR-71 in-flight test has yet to demonstrate performance which would tend to validate design specifications. The SR-71 is 20,000 pounds heavier than the A-12, which fact alone dictates the SR-71 will attain about 3,000 feet less than the A-12 at any given point in a profile of missions of the same range. Furthermore, the SR-71 project office itself

operational readiness with a deployment capability.

According to the SR-71 model specification, the planned altitude for a maximum range of 3,800 n.m. using 60% afterburner is 74 - 85,000 feet. Range for a 100% afterburner maximum altitude profile of 80 - 91,000 feet is 3,048 n.m.

According to Lockheed Aircraft Corporation Aerodynamic Report SP-237A, the planned A-12 altitude for a maximum range of 4,351 n.m. using 60% afterburner is 77,500 - 89,500 feet. Range for a 100% afterburner maximum altitude profile of 85,500 - 97,000 feet is 3,706 n.m. A maximum A-12 altitude of 90,000 feet with full afterburner has been demonstrated. An A-12 maximum unrefueled range of 2,800 n.m. at altitudes of 75,400 - 81,300 feet has been demonstrated. We feel that the figure of 90,000 feet in the Thomas paper for the SR-71 is grossly unfair and misleading, and that the 3,800 n.m. range for that aircraft is in the same category.

(Lines 34-52) No comment, other than an up-date of the figures.

Delivery date of last SR-71 should be noted, September 1967, thus limiting the full fleet SR-71 capability until early 1968.

(Lines 53-74) In treating Proposed Utilization it is apparent that

Mr. Thomas is unaware of the fact that there is a prohibition against U.S. military aircraft violating the air space of any nation be it in the Middle East, Southeast Asia, or elsewhere

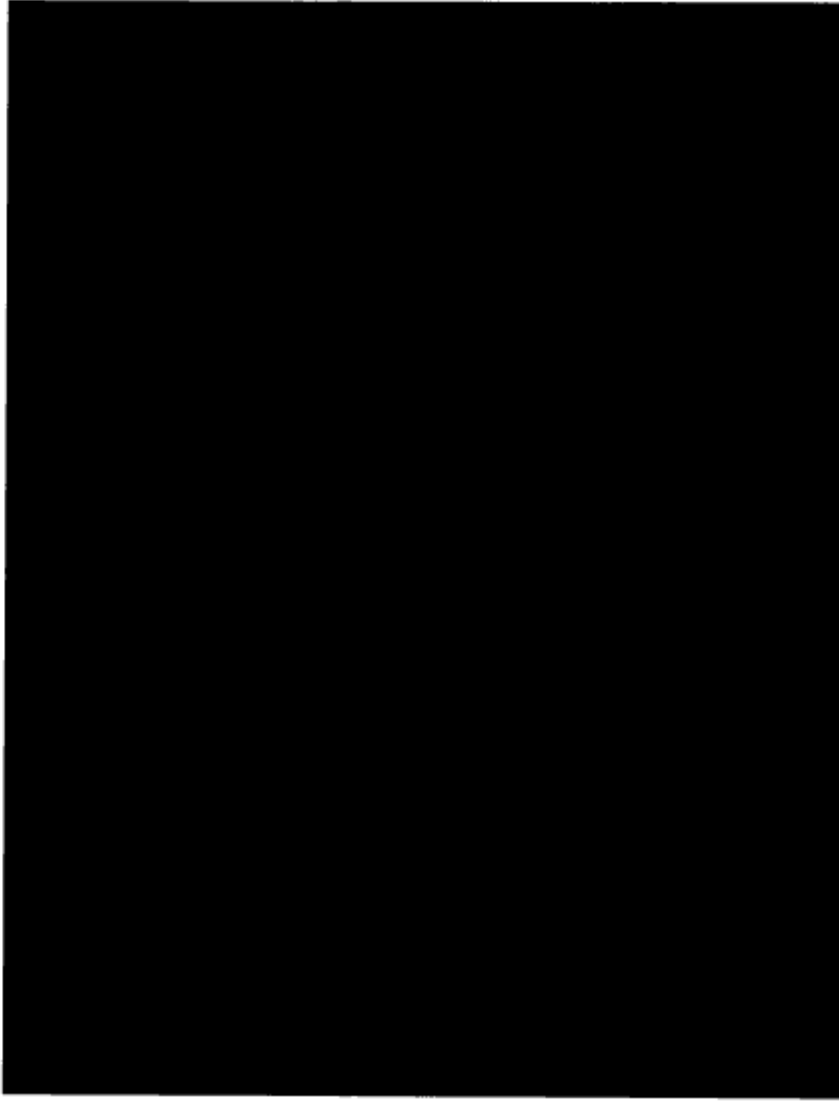
without a filed flight plan or the explicit approval of the President to so do, e.g., Cuba or North Vietnam and Laos. Except for Cuban and Vietnamese reconnaissance, the SR-71 is constrained to peripheral missions in peace time.

While not specifying the number of missions projected for the OXCART capability they would appear significantly fewer than those projected for the SR-71. Assuming that four SR-71 test aircraft will become operational aircraft (for a total then of 26 operational SR-71's) and holding six SR-71's on "hard alert for crises reconnaissance....," it would appear from Mr. Thomas' paper that 20 SR-71's would be capable of flying 134 missions in a 60 day period as opposed to 16 missions with an operational fleet of seven (not 10) OXCART vehicles. The OXCART projection is based on best professional judgment resulting from a great deal more flight experience than has been gathered in the SR-71 program. Thus, the projected ratio is somewhat out of balance with the SR-71 flying at a factor of 6.7 and the OXCART at a factor of 2.3. Obviously, the projections were pulled out of thin air. Moreover, no mention is made of the immediate availability of the OXCART as opposed to the severely limited SR-71 capability in being.

Mr. Thomas assigns, as one of three overflight missions to the SR-71, the Middle East and Southeast Asia, and to the

appear. To the reader, who would not examine closely the assigned missions, it would be ^{implicit} that the SR-71 has reconnaissance responsibility for China. Unless there have been major policy reversals by the NSC, 303 Committee, or high authority, this responsibility resides on the covert side of manned overhead reconnaissance.

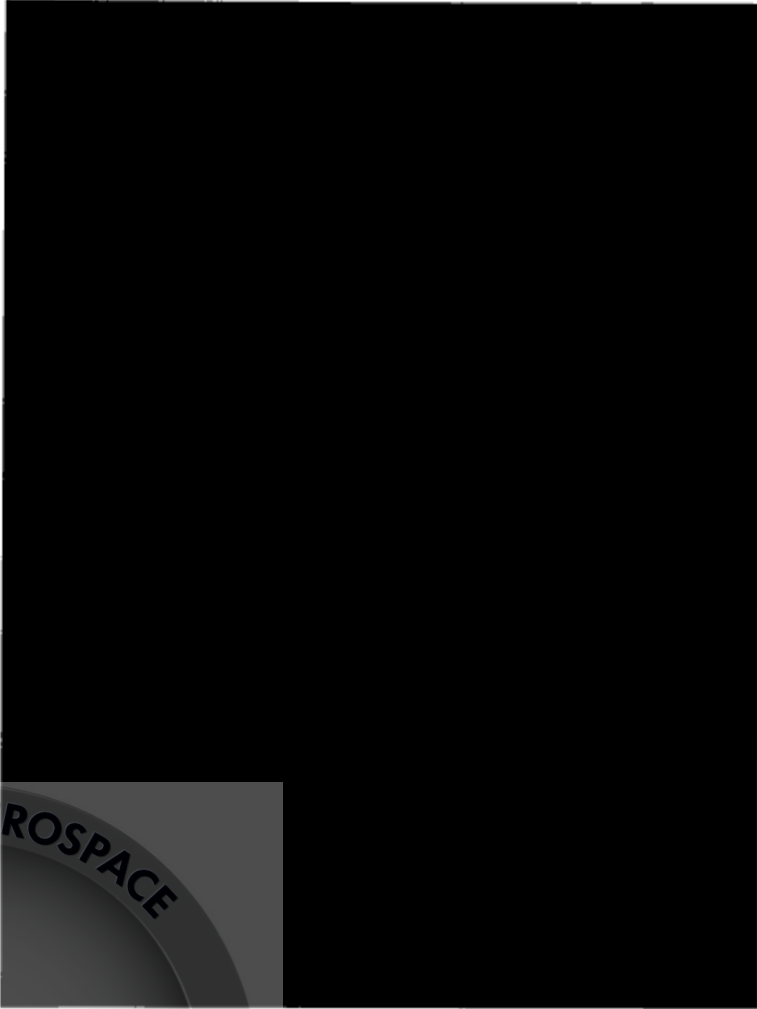
25X1A



Approved For Release 2000/08/25 : CIA-RDP33-02415A000800290012-8

25X1A





(Lines 101 - 104) It is neither for Mr. Thomas or the writer to determine whether overflights are to be attributed to clandestine or military departments. That is a decision for the President to make in consultation with the highest councils in government. To measure the value of a covert reconnaissance asset in dollars is a difficult chore. Certainly the people of the United States would not quarrel with the cost of the U-2 program from conception through that day, 14 October 1962, when the



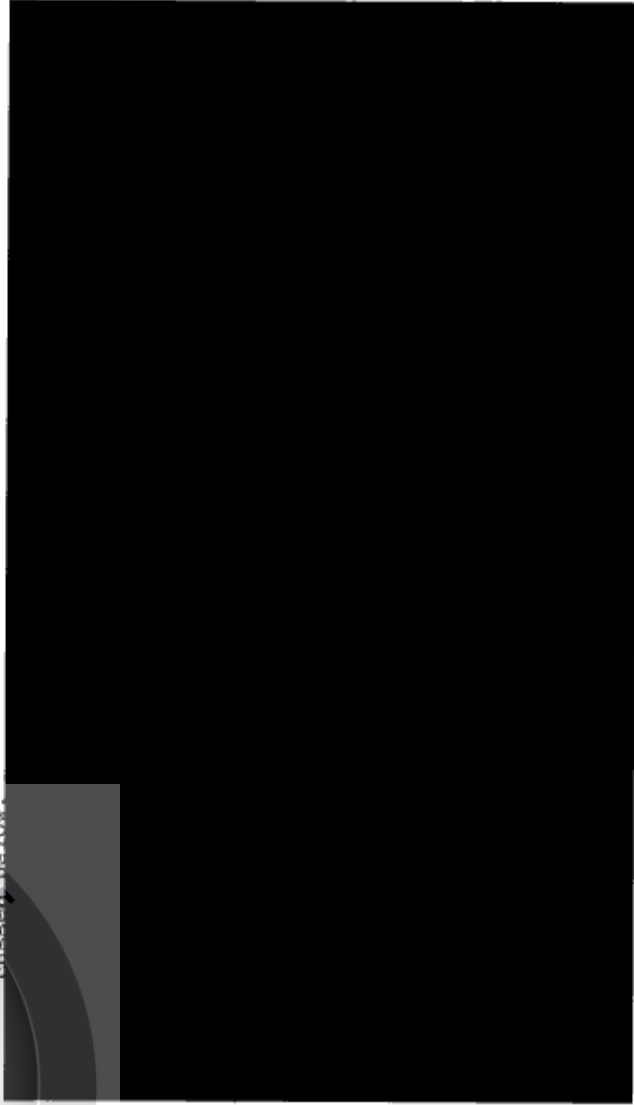
25X1A

Approved For Release 2000/08/25 : CIA-RDP33-02415A000800290012-8

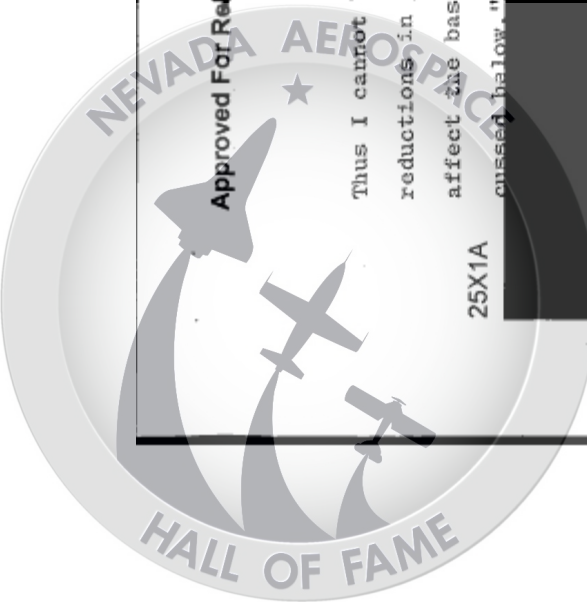


Thus I cannot but disagree with Mr. Thomas when he writes that reductions in projected budget requirements "...would not affect the basic economics of the alternatives which are discussed below."

25X1A



(Lines 123-162) Alternative 1 - No comment to recommendation to procure more SR-71's since a decision has been made since the memorandum was written. No comment to the predicted attrition rate of the SR-71, except to mention that the first SR-71 loss has been experienced since Mr. Thomas wrote his memorandum. Mr. Thomas writes: "The only thing that will be lost is the A-12's (OXCART) claimed distinction of covert overflights."



As indicated in our discussion above, we do not believe this distinction is meaningful. It is certainly not worth the cost of maintaining the A-12 program." The initial assignment of responsibility for covert overflight of hostile territory to the CIA was a Presidential decision based on the strong recommendation of the so-called Land Committee which concluded that it was "dangerous for one of our military arms to engage directly in extensive overflight." The 1 May incident of 1960 and its aftermath provide no evidence which would indict the validity of that decision. On the contrary, the Soviets engaged in extravagant, but unsuccessful, efforts to link Powers with the military in order to strengthen their propaganda position. His documentation and identity with CIA, however, had been too well established for them to make even a superficially convincing case. It is our strong conviction that we would be doing a considerable disservice to the President ~~xxxx~~ were we to permit the OXCART capability to be lost. As has been demonstrated over the last nine years, the flexibility of choice between committing a military asset or a non-military asset with non-military attribution has been most advantageous... It also should be pointed out that, when advised of OXCART's operational status and readiness to deploy to Kadena in late 1965, Mr. McGeorge Bundy, while feeling the time was not appropriate then for such a move, stated it was an ace we should keep in our sleeve

When Mr. Thomas speaks of disposing of the OXCART aircraft, he does not suggest the method of disposal. To mothball the OXCART fleet under this proposal would be a scandalous waste of an asset. He also suggests disposing of them at a time (September 1966) when there will not be a fully operationally ready capability to assume the OXCART role.

25X1A

A decision to close [redacted] is unwise for several reasons. It denies to TAGBOARD any semblance of covertness. Simply to state that as great a degree of security can be afforded to that program at [redacted] as is afforded the IDEALIST program at Edwards AFB is not the complete story. Unadmittedly, physical security could be maintained, but speculative conjecture on the part of base and off-base personnel could not be contained. The TAGBOARD, fully rigged, is an unusual configuration, to say the least, and its mission could be surmised easily. The same would obtain with the OXCART program by basing the A-12 fleet at an accessible airfield facility. At the present rate of expenditure, the

25X1A

25X1A

[redacted] is not a firm figure. It is a paper savings having no relation to actual dollar volume for the years covered.

25X1A

Approved For Release 2000/08/25 : CIA-RDP33-02415A000800290012-8

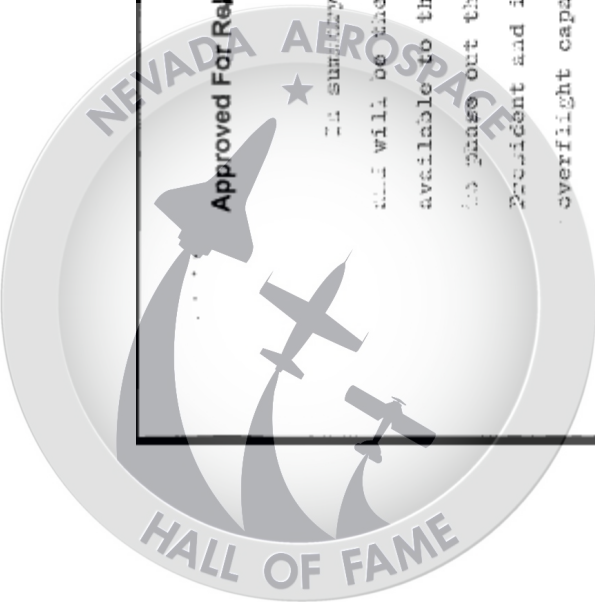
Next 1 Page(s) In Document Exempt




It is surmised that the OXCART program is
and will be the only integrated supersonic reconnaissance asset
available to the United States Government through calendar 1966.
The phase out of the OXCART now on in 1967 would be to deny the
President and indeed the United States a non-military (covert)
overflight capability. The lack of intelligence information
available only from high resolution overhead reconnaissance
severely restricts policy and decision making ability of the
Chief Executive.

25X1A

Assistant for Programs
Research and Development
Special Activities





Title:	OFFICE OF SPECIAL ACTIVITIES DD/S&T CHRONOLOGICAL HISTORY
Abstract:	
Pages:	0005
Pub Date:	8/30/1966
Release Date:	7/17/2001
Keywords:	OXCART SR-71 BLACKBIRD BLACK SHIELD A-12
Case Number:	F-2000-01388
Copyright:	0
Release Decision:	RIFPUB
Classification:	U

30 AUG 1966

OFFICE OF SPECIAL ACTIVITIES
DD/S&T
CHRONOLOGICAL HISTORY

25X1A

1. OSA began its life organizationally in early 1955 as a small project group of about [redacted] people grafted onto the staff of R. M. Bissell, Jr., then Special Assistant for Policy Coordination, Office of the DCI (SAPC/DCI). The project, of course, was the covert development and operation of the U-2 aircraft in conjunction with the USAF, and was known as Project AQUATONE. A formal agreement with Air Force was signed by Mr. Dulles and General Twining in June of that year, delineating areas of responsibility for both parties to the pact.

25X1A

2. The SAPC/DCI relationship continued as the Project grew, but as it emerged and gave signs of surviving beyond the 13 to 17 months operational life forecast for it as the beginning, and as field detachments were deployed with more than [redacted] people each, by mid-1957, SAPC/DCI strength topped [redacted] people. Technically, this brought the on-board strength of the Director's Office to some [redacted] bodies, and when this was brought to Mr. Dulles' attention, he was horrified and directed that something be done to reduce the apparent swelling in his personal staff. The AQUATONE personnel were separated from Mr. Bissell's personal staff and renamed the Development Projects Staff, retaining their organizational affiliation with the Director only in the term DPS/DCI. Mr. Bissell wore two hats as SAPC/DCI and as Chief, DPS. The group which became later known as COMOR, was attached to SAPC/DCI as the ARC (Ad Hoc Requirements Committee), the first unified effort to codify strategic intelligence requirements and to differentiate them from tactical intelligence requirements.

25X1A

25X1A

3. This condition pertained until February 1959, when Mr. Bissell became DD/P. At that point, the group was renamed Development Projects Division and was headed for the first time by an Air Force Officer, and at the same time, the old Air-Maritime Division of DD/P (which was by then all air and no maritime, and in reality, functioned as a staff supervising clandestine air operations around the world) was absorbed into DPD.

4. By the time DPD was blended into DD/P, it was no longer single project-oriented, even leaving aside the inclusion of AMD assets. In 1958, preliminary work had begun on a successor system to AQUATONE (by then named CHALICE) under the cryptonym GUSTO. Active work was under way on development of Project CORONA, a satellite photo system which emerged from the ashes of the abortive Air Force System 117L (Pied Piper), cancelled as a cover ploy in March 1958, to permit covert development of CORONA ostensibly under ARPA. In September 1959, OXCART became a project

25X1A

25X1A

Handle via [redacted] Control System

Approved for Release: JUL 2001



~~TOP SECRET~~

succeeding GUSTO, so on 1 January 1960, DPD was on the verge of launching with Air Force the first CORONA mission (it was unsuccessful), it was operating two major CHALICE detachments overseas (Turkey and [redacted] and it was starting to work cutting titanium for the first OXCART Mach 3 aircraft. It was also conducting, in the Air Branch,

25X6

25X1C

25X1C

6. On 28 February 1962, with the resignation of Mr. Bissell as DD/P, DPD was transferred to the newly formed DD/R, coincident with its move in March of 1962 to the new building. It was also renamed OSA at the same time.

25X1A

25X1A

7. Following establishment of the NRO by DOD/CIA agreement of 13 March 1963, it was not long before satellite operations responsibility moved to the SOC of NRO in the Pentagon (1964). OSP was formed shortly after establishment of DD/S&T in the fall of 1963. OSP then assumed all responsibility for satellite systems and OSA reverted to concern only with manned reconnaissance systems (IDEALIST, OXCART) and development of downstream state-of-the-art manned systems like ISINGLASS. The new version of the U-2 will also be lodged in OSA.

MILESTONE DATES

24 November 1954	U-2 Project approved by President.
10 June 1955	USAF/CIA Agreement on Project AQUATONE.
June 1955	Project AQUATONE staff formed under SAPC/DCI.
6 August 1955	First flight of U-2, eight months after contract let.
7 May 1956	First U-2 detachment deployed to [redacted]
20 June 1956	First U-2 overflight of Soviet Bloc countries.
4 July 1956	First U-2 flight over Russia.

25X6

25X6

- 2 - ~~TOP SECRET~~



~~TOP SECRET~~

	20 August 1956	Second U-2 detachment deployed to Adana, Turkey.
25X6	11 September 1956	First U-2 overflight (of Middle East) from Turkey.
25X6	February 1957	Third U-2 detachment deployed to [REDACTED]
	20 June 1957	First U-2 overflight in Far East over Russia.
25X6 25X6 25X6	November 1957	First U-2 detachment disbanded at [REDACTED]. Assets divided between Turkey and [REDACTED] units.
	March 1958	Project CORONA started; 117L system (Pied Piper) cancelled by USAF.
	1 September 1958	Land Panel approved GUSTO effort leading to OXCART; first GUSTO contract let.
	21 January 1959	First CORONA launch.
	June 1959	Presidential approval for OXCART advanced feasibility study.
	4 September 1959	Letter of intent with Lockheed for OXCART.
25X1A	November 1959	CORONA [REDACTED]
	November 1959	Presidential approval to proceed with OXCART.
	8 February 1960	Production contract for OXCART let.
	1 May 1960	Last U-2 overflight of Russia.
	20 August 1960	First successful CORONA flight after 13 failures.
25X1A	September 1960	[REDACTED]
25X1A	October 1960	U-2 detachment in Turkey returned to U. S.; regrouped at [REDACTED].
	26 October 1960	First U-2 flight over Cuba from U. S.

- 3 -

~~TOP SECRET~~



~~TOP SECRET~~

25X1C	November 1960	[REDACTED]
25X1C	14 December 1960	U-2 detachment in [REDACTED]
25X6	January 1961	[REDACTED]
25X6	15-19 April 1961	Air operations, Bay of Pigs.
25X1A	26 April 1962	First flight of OXCART aircraft, [REDACTED]
25X1A	9 May 1962	First [REDACTED] flight of OXCART aircraft.
	5 October 1962	Last CIA U-2 flight over Cuba (50 flown in all).
	29 February 1964	A-11 surfaced by President.
25X1C	20 May 1964	First carrier mission for U-2 over [REDACTED]
25X1C	23 November 1965	OXCART declared operationally ready.

OSA ACCOMPLISHMENTS

1. Developed and operated U-2 program for ten years (1956-66).
- 25X1A 2. Developed first operational satellite reconnaissance system in world.
- 25X1A 3. Developed first operational [REDACTED] aircraft in world.
4. Developed TALENT and TKH systems plus [REDACTED] system.
5. Established CIA world-wide security courier system and first CIA industrial security system.
- 25X1C 6. Furnished entire air support to Cuban operation.
7. Established and operated first effective [REDACTED]
8. Located first SA-2 site in Cuba during 1962 missile crisis.

~~TOP SECRET~~



~~TOP SECRET~~

Approved For Release 2000/04/13 : CIA-RDP69B00596R000100070018-0

- 9. Established first combined world-wide communications and avionics capability in CIA.
- 10. Established first and only CIA-industry secure communications network.
- 11. Handled over [REDACTED]

25X1A
25X1A

SA/DD/S&T/JACunningham, Jr.:mep

Distribution:

25X1A

- Copy 1 - DD/S&T
- Copy 2 - DD/OSA
- Copy 3 - DD/OSA
- Copy 4 - [REDACTED] DD/S&T
- Copy 5 - [REDACTED] DD/S&T
- Copy 6 - Exec. Officer, DD/S&T
- Copies 7 & 8 - DD/S&T Registry
- Copies 9, 10, 11 & 12 - James A. Cunningham, Jr.
- Copy 13 - [REDACTED]
- Copy 14 - [REDACTED]

25X1A

~~TOP SECRET~~



Title:	ADVANCED RECONNAISSANCE AIRCRAFT
Abstract:	
Pages:	0001
Pub Date:	12/27/1966
Release Date:	3/28/2000
Keywords:	RECONNAISSANCE AIRCRAFT MISSIONS SR-71 A-12 AIRCRAFT
Case Number:	EO-1998-00633
Copyright:	0
Release Decision:	RIFPUB
Classification:	U





~~SECRET~~
CENTRAL INTELLIGENCE AGENCY
 WASHINGTON, D. C. 20505
 OFFICE OF THE DIRECTOR

LBJ LIBRARY
 Mandatory Review
 Case # NLJ 98-495
 Document # 33

5354
 33

*For the President
 from Walt Rostow
 Adm. Rufus Taylor, Dick Helms' Deputy, called
 today and said the
 final memo to
 you on the
 SR-71 -
 A-12
 problem
 did not
 quite
 fully
 reflect
 Helms'
 opinion.
 His
 statement
 followed.
 As since
 I haven't
 seen the
 Budget
 Bureau
 memorandum
 I can not
 comment.*

27 December 1966

MEMORANDUM FOR: The Honorable W. W. Rostow
 Special Assistant to the President
 SUBJECT : Advanced Reconnaissance Aircraft

Further to our telephone conversation of this date, this Agency feels that the draft memorandum on this subject prepared by the Director of the Bureau of the Budget does not quite fully reflect the opinion of the Director of Central Intelligence in that:

"The SR-71 aircraft cannot yet be considered essentially interchangeable with the A-12 for operational purposes because the A-12 has been fully operational for one year and has already demonstrated greater performance for peacetime reconnaissance missions than has the SR-71, which has not yet achieved an operational capability."

Rufus Taylor
 Rufus Taylor
 Acting Director



~~SECRET~~

TS 188890
 Copy 1

Title:	(EST PUB DATE) AIRCRAFT ACCIDENT/INCIDENT INVESTIGATION
Abstract:	
Pages:	0003
Pub Date:	1/1/1967
Release Date:	7/24/2001
Keywords:	OXCART SR-71 BLACKBIRD BLACK SHIELD A-12
Case Number:	F-2000-01388
Copyright:	0
Release Decision:	RIFPUB
Classification:	U



dst 218972

Approved For Release 2000/09/11 : CIA-RDP71B00263R000200130007-7

~~SECRET~~

25X1A2d2

0182-67
Copy 10 of 13

MEMORANDUM FOR: Deputy Director for Plans

SUBJECT: Aircraft Accident/Incident Investigation

REFERENCE: Memorandum from DDP to DDS&T and DDS, dated 1 November 1967. Subject: Informal Reviews of Aircraft Accidents or Incidents by DDP Special Operations Division Accident/Incident Investigation Board (DD/P 7-4664)

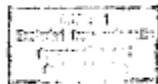
1. The DDS&T and the Office of Special Activities (OSA) much appreciate your kind offer of the use of your Special Operations Division Accident/Incident Investigation Board. Should we encounter exceptional situations in our activities requiring the use of a special board, we will avail ourselves of the capability noted in referenced memorandum.

2. In view of the somewhat joint CIA/USAF nature of the DDS&T/OSA programs and Air Force vital interest, in addition to ours, in reports, we normally follow the procedures outlined below in accidents/incidents involving OSA aircraft:

a. USAF aircraft assigned to OSA activities: The incident/accident is investigated and a report rendered by a board of Air Force personnel in accordance with Air Force Regulation 127-4, "Investigation and Reporting of U. S. A. F. Aircraft Accidents/Incidents".

b. OXCART: Incidents/accidents involving the OXCART aircraft are investigated and reported upon by a specially augmented board of cleared Air Force personnel (familiar with technical equipment in use) usually from the Office of the Inspector General, USAF, Norton Air Force Base, in accordance with AFR-127-4.

25X1A2d2



~~SECRET~~
IDEALIST/OXCART

Handle Via [REDACTED]
Control System

Approved For Release 2000/09/11 : CIA-RDP71B00263R000200130007-7



~~SECRET~~

25X1A2d2

██████████-0182-67
Page 2

c. U-2: Incidents/accidents involving the U-2 are investigated by a board of Air Force personnel (familiar with technical equipment in use) from OSA and technical personnel from the Lockheed Aircraft Corporation and elsewhere, as required. Their investigation and report is conducted along the guidelines laid out by AFR-127-4.

CARL E. DUCKETT
Deputy Director
for
Science and Technology

cc: DDS

25X1A2d2

~~SECRET~~

Handle Via ██████████
Control System



~~SECRET~~

25X1A2d2

██████████-0182-67
Page 3

SIGNATURE RECOMMENDED:

25X1A9a

████████████████████
Acting Director of Special Activities

25X1A9aDD/SA/██████████mcm(24 Nov 67)

Distribution:

- 1 - DDP
- 2 - DDS
- 3 - DDS&T
- 4 - DDS&T Registry
- 5 - DDS&T Chrono
- 6 - D/SA
- 7 - DD/SA
- 8 - D/O/OSA
- 9 - OXC/O/OSA
- 10 - IDEA/O/OSA
- 11 - SAS/O/OSA
- 12 - Chrono
- 13 - RB/OSA

~~SECRET~~

Handle Via ██████████
Control System

25X1A2d2



Title:	LOSS OF OXCART A-12 AIRCRAFT
Abstract:	
Pages:	0003
Pub Date:	1/6/1967
Release Date:	7/17/2001
Keywords:	OXCART SR-71 BLACKBIRD BLACK SHIELD A-12
Case Number:	F-2000-01388
Copyright:	0
Release Decision:	RIFPUB
Classification:	U



~~TOP SECRET~~

Handle via [redacted] Release 2000/05/05 OXCART CIA-RDP71B00590R000100080017-0

Control System

25X1A

[redacted] 2015-67

Copy 6

6 January 1967

BRIEFING MEMORANDUM FOR ACTING DEPUTY DIRECTOR FOR SCIENCE AND TECHNOLOGY

SUBJECT: Loss of OXCART A-12 Aircraft

25X1A

1. Aircraft No. 125 departed [redacted] on 5 January 1967 at 1959Z (1159 PST) on a normal high-altitude training mission. [redacted] was the pilot. Information available at this time indicates that the aircraft crashed approximately 60 miles East of [redacted]. The fate of the pilot is unknown.

25X1A
25X1A
25X1A

2. The preliminary accident report from [redacted] indicates that at 2356Z (1556 PST) [redacted] reported his aircraft position as 130 miles East of [redacted] with only 4000# of fuel remaining and that fuel was being consumed at an excessive rate. At 2359Z (1559 PST) [redacted] transmissions received by [redacted] indicated a low fuel condition (less than 3000#) and that the aircraft was below 60,000 feet. At 0003Z (1603 PST), [redacted] advised that double engine flame-out was being experienced and that he was ejecting; aircraft position was approximately 67 miles East of [redacted]. The reported aircraft impact point has not been confirmed as that of aircraft 125, nor has it been established that [redacted] was able to successfully eject from the aircraft. Search and rescue operations are continuing. Attached are supporting charts depicting the planned route and key events known at this time.

25X1A
25X1A
25X1A
25X1A
25X1A
25X1A
25X1A

3. The following is a summary of [redacted] Project/flying experience:

25X1A

25X1A

Handle via [redacted]
Control System

Approved For Release 2000/05/05 OXCART CIA-RDP71B00590R000100080017-0

Approved for Release: JUL 2001



Handle via [redacted]
Control System

25X1A

~~TOP SECRET~~
~~OXCART~~

Approved For Release 2000/05/05 : CIA-RDP71B0059 [redacted] 8160080017-0 25X1A

- a. Joined Project OXCART on 7 November 1962.
- b. Total flying hours: 3354:55
- c. Total A-12 flying hours: 358:20

4. Necessary "backstopping" to prevent unauthorized disclosures of the accident have been arranged through Hq USAF (AFRDR-P). No releases by the news media are known to have occurred to this time (0700 EST). As appropriate to the circumstances, a coordinated cover story will be released through the Air Force.

5. Appropriately cleared Air Force inspectors have arrived at [redacted] and the accident investigation is underway.

25X1A

SIGNED

PAUL N. BACALIS
Brigadier General, USAF
Director of Special Activities

Attachment:
As stated

Distribution:
#1 - A/DD/S&T
#2 - A/DD/S&T
#3 - A/DD/S&T
#4 - D/SA
#5 - D/O/OSA
#6 - OXC/O/OSA
#7 - RB/OSA (w/o attach)
#8 - CHRONO (w/o attach)

25X1A

NEVADA AEROSPACE



Approved For Release 2000/05/05 : CIA-RDP71B0059 [redacted] 8160080017-0

~~OXCART~~
~~TOP SECRET~~

Handle via [redacted]
Control System

SECRET

Approved For Release 2000/06/05 : CIA-RDP71B00890R000100060017-0

Next 4 Page(s) in Document Exempt

Approved For Release 2000/06/05 : CIA-RDP71B00890R000100060017-0



Title:	A-12 ACCIDENT STATUS REPORT
Abstract:	
Pages:	0002
Pub Date:	1/9/1967
Release Date:	7/17/2001
Keywords:	OXCART SR-71 BLACKBIRD BLACK SHIELD A-12 ACCIDENT
Case Number:	F-2000-01388
Copyright:	0
Release Decision:	RIFPUB
Classification:	U



224

Handle via [redacted]
Control System

~~SECRET~~
OX CART

Release 2000/05/05 : CIA-RDP71B00590R000100080016-1
25X1A

25X1A

[redacted] 2016-67
Copy 6

9 January 1967

BRIEFING MEMORANDUM FOR THE ACTING DEPUTY DIRECTOR FOR SCIENCE AND TECHNOLOGY

SUBJECT: A-12 Accident Status Report

REFERENCE: [redacted] 2015-67, 6 January 1967, Subject: "Loss of OXCART A-12 Aircraft"

25X1A

The following is furnished as updating information to referenced memorandum:

1. The aircraft crash site was located and confirmed at 2306Z (1506 PST), 6 January 1967. It is [redacted] near the small town of [redacted]. The aircraft was found to be totally destroyed upon impact.

25X1A
25X1A
25X1A

2. The body of [redacted] the A-12 pilot, was located at 2200Z (1400 PST), 7 January 1967. He was found in the pilot's ejection seat which impacted approximately five miles East of the aircraft wreckage.

25X1A

3. After notification of next-of-kin, a final coordinated press release was made by the Air Force at approximately 11:30 P.M., Eastern Standard Time, 7 January 1967.

4. The investigation of the accident cause and the reason for the pilot's unsuccessful separation from the ejection seat is continuing.

SIGNED

PAUL N. BACALIS
Brigadier General, USAF
Director of Special Activities

Distribution:

- #1 - A/DD/S&T
- #2 - A/DD/S&T
- #3 - A/DD/S&T
- #4 - D/SA
- #5 - D/O/OSA
- #6 - OXCART/OSA
- #7 - RB/OSA
- #8 - Chron

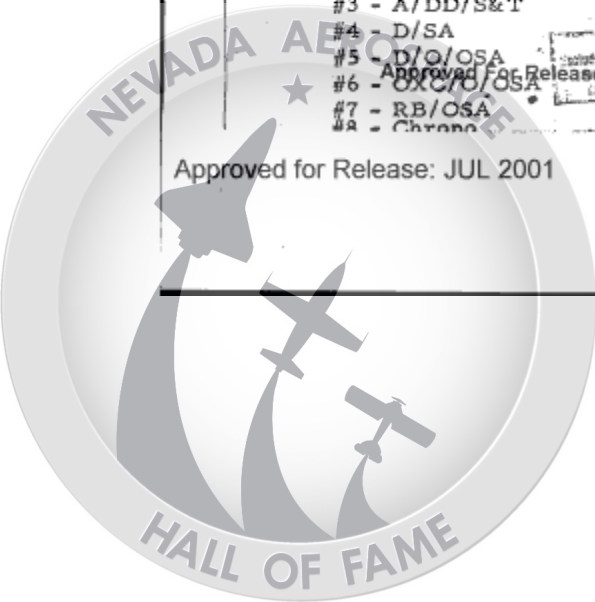
25X1A

GROUP 1
Excluded from automatic
downgrading and
declassification

Release 2000/05/05 : CIA-RDP71B00590R000100080016-1
~~SECRET~~

Handle via [redacted]
Control System

Approved for Release: JUL 2001



25X1A

Approved For Release 2000/05/05 : CIA-RDP71B00590R000100080016-1

Next 1 Page(s) In Document Exempt



Approved For Release 2000/05/05 : CIA-RDP71B00590R000100080016-1

Title:	LOSS OF ARTICLE 125 (OXCART AIRCRAFT)
Abstract:	
Pages:	0004
Pub Date:	1/25/1967
Release Date:	7/17/2001
Keywords:	OXCART SR-71 BLACKBIRD BLACK SHIELD A-12
Case Number:	F-2000-01388
Copyright:	0
Release Decision:	RIFPUB
Classification:	U



227

25X1A

Approved For Release 2000/05/05 : CIA-RDP71B00590R000100080014-3
HANDLE VIA ██████████ CONTROL SYSTEM
~~SECRET~~
OXART

25X1A

██████████ 2028-67
Copy 5 of 8
25 January 1967

MEMORANDUM FOR: Acting Deputy Director for Science and Technology
SUBJECT: Loss of Article 125 (OXART Aircraft)

1. This memorandum is for your information.
2. The Air Force Flight Safety Team has completed its investigation of the accident involving Article 125. While no precise cause could be established for the loss, it was considered most probable that a fuel gauging error led to fuel starvation and engine flame-out ██████████
██████████ The pilot ejected successfully but was unable to separate from the seat and was killed upon impact.
3. Personnel involved in the accident investigation were able to simulate the type of fuel gauging error to which the accident could be attributed. This type of error is induced when the shield of the fuel tank probe in tank number three is grounded to aircraft structure. The nature of the error is such that it varies in proportion to the amount of fuel in the tank. This is: the more fuel in the tank, the greater the error. As fuel is used the total fuel indication returns to near normal and the pilot is suddenly faced with an unexplained apparent loss of fuel. Gauging errors such as this are not readily apparent to the pilot.

25X1A

25X1A

25X1A

GROUP 1
Excluded from automatic
downgrading and
declassification

~~OXART~~
~~SECRET~~

HANDLE VIA ██████████
CONTROL SYSTEM

Approved For Release 2000/05/05 : CIA-RDP71B00590R000100080014-3

Approved for Release: JUL 2001



25X1A

HANDLE VIA ██████████
CONTROL SYSTEM

~~SECRET~~
~~OX CART~~

██████████-2028-67
Page 2

25X1A

4. Failure of the pilot to separate from the ejection seat was attributed to wedging of the parachute and seat kit assembly in the seat upon actuation of the seat separation mechanism and possible binding of the lap belt release assembly. The latter could not be conclusively proven. However, wedging of the parachute/kit assembly could be demonstrated with the seat head rest installed.

5. Actions are currently underway to inspect all aircraft fuel gauging systems, improve calibration procedures and provide a positive method of cross-checking fuel aboard versus indicated. All ejection seats are undergoing inspection and head rests are being removed pending redesign. Upon completion of these actions it is planned to release the aircraft for flight.

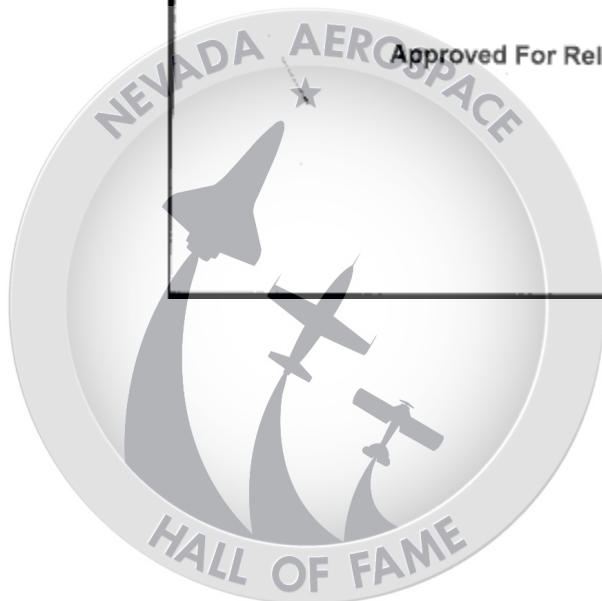
25X1A

████████████████████
Acting Director of Special Activities

25X1A

~~OX CART~~
~~SECRET~~

HANDLE VIA ██████████
CONTROL SYSTEM



25X1A
25X1A

HANDLE VIA ██████████
CONTROL SYSTEM

~~SECRET~~
OXCART

██████████-2028-67
Page 3

25X1A

D/M/OSA ██████████ let (24 January 1967)

Distribution:

- #1 - ADDS&T
- #2 - DDS&T Registry
- #3 - D/SA
- #4 - D/O/OSA
- #5 - OXC/O/OSA
- #6 - D/M/OSA
- #7 - D/M/OSA (chrono)
- #8 - RB/OSA

25X1A

OXCART
~~SECRET~~

HANDLE VIA ██████████
CONTROL SYSTEM



25X1A

Approved For Release 2000/05/05 : CIA-RDP71B00590R000100080014-3

Next 1 Page(s) In Document Exempt



Approved For Release 2000/05/05 : CIA-RDP71B00590R000100080014-3

Title:	PRELIMINARY ASSESSMENT OF 19 AND 20 JULY 1967 BLACK SHIELD PHOTOGRAPHY
Abstract:	
Pages:	0005
Pub Date:	7/26/1967
Release Date:	11/13/2000
Keywords:	ASSESSMENT PHOTOGRAPHY PRELIMINARY RECONNAISSANCE PHOTOGRAPH BLACK SHIELD
Case Number:	EO-1998-00368
Copyright:	0
Release Decision:	RIPPUB
Classification:	U



~~TOP SECRET~~

4a

LBJ LIBRARY
Mandatory Review
Case # NLJ 98-361
Document # 4a

1

APPROVED FOR RELEASE
DATE: NOV 2000

~~THIS DOCUMENT CONTAINS CODE WORD MATERIAL~~

WARNING

~~This document contains classified information affecting the national security of the United States within the meaning of the espionage laws, US Code, Title 18, Sections 793, 794, and 798. The law prohibits its transmission or the revelation of its contents in any manner to an unauthorized person, as well as its use in any manner prejudicial to the safety or interest of the United States or for the benefit of any foreign government to the detriment of the United States.~~

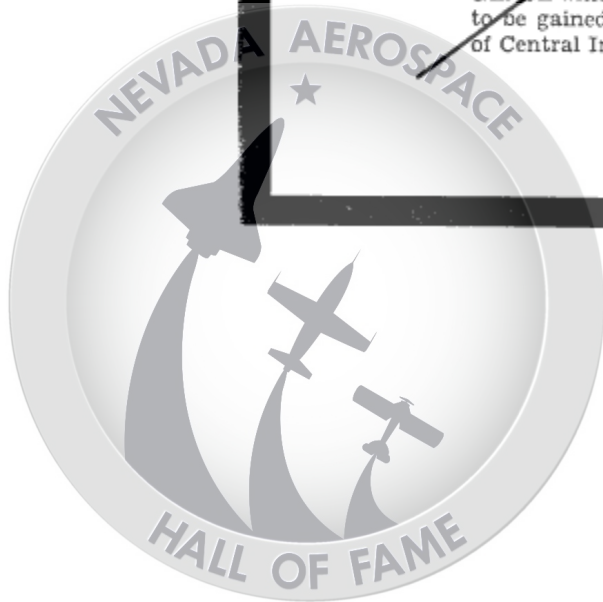
~~THIS DOCUMENT MUST BE KEPT IN COMMUNICATIONS INTELLIGENCE CHANNELS AT ALL TIMES~~

~~It is to be seen only by US personnel especially indoctrinated and authorized to receive COMMUNICATIONS INTELLIGENCE information; its security must be maintained in accordance with COMMUNICATIONS INTELLIGENCE REGULATIONS.~~

~~No action is to be taken on any COMMUNICATIONS INTELLIGENCE which may be contained herein, regardless of the advantages to be gained, unless such action is first approved by the Director of Central Intelligence.~~

~~GROUP 1
EXCLUDED FROM AUTOMATIC DOWNGRADING
AND DECLASSIFICATION~~

~~TOP SECRET~~



~~TOP SECRET TRINE~~
No Foreign Dissem

SC NO. 08720/67
26 July 1967

MEMORANDUM

SUBJECT: Preliminary Assessment of 19 and
20 July 1967 BLACK SHIELD Photography

Summary

Two BLACK SHIELD missions flown about 24 hours apart on 19 and 20 July obtained cloud-free photography of about 80 percent of North Vietnam, including most of the high priority surface-to-surface missile search areas, much of the North Vietnamese air defense system, and many US strike and interdiction target areas. No evidence of surface-to-surface missile deployment was detected.

Note: This memorandum was prepared by the Directorate of Intelligence with the assistance of the Directorate of Science and Technology.



~~No Foreign Dissem~~
~~TOP SECRET TRINE~~

EO 12958
3.4(h)(1)-25Yrs
(T)

1. Mission 6709 on 19 July obtained photography of about 75 percent of North Vietnam, including the southern DRV down to the DMZ and the Hanoi-Haiphong area. Weather conditions were excellent with the exception of a few scattered areas. Mission 6710 on 20 July covered the DMZ and the area to the north, the Hanoi-Haiphong area, and parts of the Sino-DRV border. Light to heavy haze and cloud cover hampered intelligence exploitation of the 20 July photography, however, especially in the Sino-DRV border area. (A [REDACTED] U-2 mission over South China on 20 July provided some coverage of the border, however.)

2. No evidence of surface-to-surface missile deployment was obtained by either BLACK SHIELD mission. The two missions covered most of the high priority MRBM search areas west and north of Hanoi and the tactical and coastal defense missile search areas in the southern and central DRV.

3. North Vietnamese air defenses: The mission of 19 July photographed 166 of the almost 200 usable surface-to-air missile (SAM) sites, including four new sites in the Yen Bai area. Of the 137 sites which could be read out, 12 were occupied (including 2 new ones), 124 were unoccupied, and one near Yen Bai has been returned to cultivation. The mission of 20 July covered 80 SAM sites, including two new ones (one occupied) in the Haiphong area. Five sites were occupied, 63 unoccupied, and the occupancy of 12 could not be determined.

EO 12958
3.4(h)(1)-25Yrs
(T)

4. The level of SAM site occupancy falls slightly below our estimate that the North Vietnamese have between 25 and 35 SAM firing battalions, but we cannot tell how many units may have been shifting locations at the time of the photography. Previous BLACK SHIELD missions have photographed up to 20 firing battalions at one time, [REDACTED]

5. The two missions together covered the seven major North Vietnamese airfields, but a firm air order of battle (AOB) cannot be derived because



weather conditions and variations in flight paths prevented simultaneous coverage of all seven. Despite these limitations, it appears that the current estimate of fighter strength is fairly accurate. The photography revealed that the mix of fighter types is somewhat different than we have been estimating, however. For example, 10 MIG-21 and 25 MIG-15/17 fighters were photographed on the 19th. Our estimate as of that day was that a total of 29 fighters remained in the DRV--16 MIG-21s and 13 MIG-15/17s.

6. On the basis of this photography--and taking account of subsequent losses as well as aircraft airborne at the time of the photography--it appears that there are now between 25 and 35 jet fighters stationed in the DRV. Of these, at least 10 are MIG-21s.

7. Bomb damage assessment (BDA): The two missions obtained extensive coverage of targets of the US strike effort in North Vietnam. All 23 of the targets being followed at first priority in CIA's BDA studies were covered, as well as nearly all of those being followed at second priority.

8. Coverage of the Hanoi power plant provided the best photography since the US strike of 10 June. Repair work is under way on both the damaged boilerhouse and the control building. The photography confirmed damage to three boilers which supplied steam for about half the generating capacity. Excellent photography of the Nam Dinh powerplant revealed destruction of the coal processing building in a strike on 26 June. Cumulative heavy damage to this facility will probably prevent even partial operation for at least six months. Coverage of the Ben Thuy powerplant showed no change since May, indicating that air strikes in early July inflicted no significant additional damage.

9. Transportation: As in previous BLACK SHIELD missions, wide coverage of rail and road transport routes and facilities was obtained. Detailed analysis of key targets such as bridges and rail yards is under way to assess the current status and

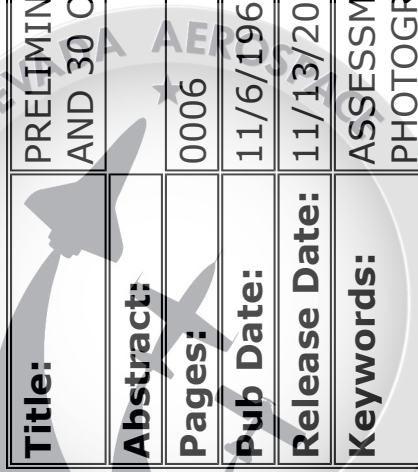


serviceability of the North Vietnamese rail system. Good coverage of the major rail lines between China and the DRV has provided information for analysis of the level of rail transport activity and the inventory of rolling stock available in the DRV. Although the coverage was extensive, however, the resolution is not good enough to determine the extent of the present program to equip the North Vietnamese meter-gauge railway system with an extra track to accommodate Chinese standard-gauge rolling stock.

10. Haiphong--the major ocean port of entry-- was covered, but haze hampered analysis. Pinghsiang, the major Chinese storage area and transportation hub near the northeastern DRV border, was photographed, but scattered clouds prevented a complete count of trucks and rolling stock.

11. Chinese activity in North Vietnam: A figure-8 driver training course was observed for the first time near the area of military camps and storage facilities probably built by Chinese engineers in the Lao Cai area at the northwest Sino/DRV border. The course, which is probably designed to train cargo truck drivers, is similar to other courses in North Vietnam and south China. Interrogation reports have mentioned North Vietnamese truck driver students being sent to south China for training. It is possible that this training is now being carried out in the sanctuary zone of northern North Vietnam.





Title:	PRELIMINARY ASSESSMENT OF BLACK SHIELD PHOTOGRAPHY OF 28, 29, AND 30 OCTOBER
Abstract:	
Pages:	0006
Pub Date:	11/6/1967
Release Date:	11/13/2000
Keywords:	ASSESSMENT OXCART PHOTOGRAPHY PRELIMINARY RECONNAISSANCE PHOTOGRAPH BLACK SHIELD
Case Number:	EO-1998-00368
Copyright:	0
Release Decision:	RIPPUB
Classification:	U

~~TOP SECRET~~

LBJ LIBRARY
Mandatory Review
Case # NLJ 98-361
Document # 1a

4237
1
1a

APPROVED FOR RELEASE
DATE: NOV 2000

BLACK SHIELD ASSESSMENT

HANDLE VIA COMINT CHANNELS

WARNING

This document contains classified information affecting the national security of the United States within the meaning of the espionage laws, US Code, Title 18, Sections 793, 794, and 798. The law prohibits its transmission or the revelation of its contents in any manner to an unauthorized person, as well as its use in any manner prejudicial to the safety or interest of the United States or for the benefit of any foreign government to the detriment of the United States.

THIS DOCUMENT MUST BE KEPT IN COMMUNICATIONS INTELLIGENCE CHANNELS AT ALL TIMES

It is to be seen only by US personnel especially indoctrinated and authorized to receive COMMUNICATIONS INTELLIGENCE information; its security must be maintained in accordance with COMMUNICATIONS INTELLIGENCE REGULATIONS.

No action is to be taken on any COMMUNICATIONS INTELLIGENCE which may be contained herein, regardless of the advantages to be gained, unless such action is first approved by the Director of Central Intelligence.

GROUP 1
EXCLUDED FROM AUTOMATIC DOWNGRADING
AND DECLASSIFICATION

~~TOP SECRET~~



~~TOP SECRET TRINE~~
~~No Foreign Dissem~~

SC No. 10384/67
6 November 1967

MEMORANDUM

SUBJECT: Preliminary Assessment of Black Shield
Photography of 28, 29, and 30 October

Summary

Three double-pass Black Shield missions flown over North Vietnam on 28, 29, and 30 October provided cloud-free photographic coverage of about 55 percent of the country, including the Hanoi, Haiphong, Pinghsiang and Dong Dang areas. All of North Vietnam's six major airfields, more than half of the SA-2 sites, over 75 percent of the rail network north of the panhandle, and 42 priority bridges and rail yards for bomb damage assessment were photographed. No evidence of surface-to-surface missile deployment was noted.

Note: This memorandum was prepared by the Directorate of Intelligence.

~~No Foreign Dissem~~
~~TOP SECRET TRINE~~



1. Three double-pass Black Shield missions flown over North Vietnam on 28, 29, and 30 October provided cloud-free photographic coverage of about 55 percent of the country, including the Hanoi, Haiphong, Pingsiang and Dong Dang areas. Both Mission 6732 (28 October) and Mission 6734 (30 October) flew two passes each over the area of North Vietnam north of the panhandle. One of mission 6732's passes was along the China border area. Mission 6733 (29 October) flew one pass primarily over the panhandle and the other pass along the China border area. No evidence of surface-to-surface missile deployment was noted.

2. Surface-to-Air Missile Sites: Over half of the nearly 260 SA-2 sites in North Vietnam were photographed by the three missions. Two new sites were detected. The 28 October mission alone covered 120 SA-2 sites. Fourteen of these sites were occupied, 70 unoccupied, and 16 could only be identified. The 29 October mission covered 61 SA-2 sites. One of these sites was occupied, 30 unoccupied (including one new site), and 30 could only be identified. The 30 October mission covered 92 SA-2 sites. Thirteen of these sites were occupied (including one new site), 74 unoccupied, and five could only be identified.

3. Airfields: Good coverage of all six of North Vietnam's major airfields was provided by the 28 October mission. With the exception of Haiphong/Cat Bi--which has a cratered runway--all the airfields appeared to be serviceable.

4. At Phuc Yen Airfield, the bomb craters on the runway had been filled in and the airfield seemed to be capable of supporting at least limited fighter

[REDACTED] Other visible bomb damage from the 24 and 25 October air strikes included: bomb craters on the two main parking aprons and the parallel taxiway; interdiction of the taxiway to the northern aircraft revetments by one bomb crater; two MIG-15/17s probably destroyed

EO 12958
3.4(b)(1)-25Yrs
(U)



and two other aircraft possibly destroyed; and seven damaged aircraft revetments.

5. At Hoa Lac Airfield, all bomb craters on the runway had been repaired, and the runway appeared to be serviceable. At Haiphong/Kien An Airfield, all bomb craters on the runway had been repaired, making it serviceable. Other bomb craters could be seen on the half-loop taxiway, in six parking revetments, and adjacent to the parallel taxiway.

6. Photography from the 29 October mission showed continuing construction at Yen Bai Airfield in the northwestern part of North Vietnam. Concrete appears to have been laid for part of the runway and parallel taxiway. Three parking aprons, 13 aircraft revetments, and a dispersal taxiway were identified. This is the first sign of progress at this airfield since 20 June. Photography taken at that time showed that preparations had been made to surface the runway. After four months, the Chinese engineers still have not completed the runway, although they have apparently made progress on some of the adjacent facilities.

7. Air Order-of-Battle: The 28 October photography of the six major airfields showed very few aircraft. At Phuc Yen Airfield, ten aircraft could be seen: two small swept-wing aircraft, four possible aircraft, two probably destroyed MIG-15/17s, and two possibly destroyed aircraft.

EO 12958
3.4(h)(1)-25Yrs
(U)

8. At Hanoi/Gia Lam Airfield, one MIG-15/17 was observed. Two derelict MIG-15/17s and two dummy MIG-21s were noted at Hoa Lac Airfield.

9. Naval Order-of-Battle: The 28 October mission photographed the normal complement of naval vessels in the Haiphong area. Identifiable vessels included three SO-1 class submarine chasers, three or



~~TOP SECRET TRINE~~

~~No Foreign Dissem~~

four Swatow-class gunboats, six P-6 class motor torpedo boats, and two P-4 class motor torpedo boats.

10. Bridges: The 28 October mission provided good coverage of the most important bridges. The Paul Doumer Railroad and Highway Bridge over the Red River was shown to be unserviceable. One span had been dropped into the river and the two adjoining spans had been severely damaged.

11. The Canal des Rapides Railroad and Highway Bridge also was shown to be unserviceable. One span at the south end of the main bridge had been knocked out of position. The alternate rail bypass bridge was also unserviceable.

12. In the Haiphong area, the three main bridges--the railroad and highway bridge and two highway bridges--were observed to be still unserviceable. Ten highway bypass bridges there were serviceable.

13. Transshipment Points: Photography of 28 October showed normal levels of activity at the Pinghsiang and Dong Dang railroad transshipment points. About 390 pieces of rolling stock, including flatcars carrying 42 unidentifiable objects, were noted at Pinghsiang. Approximately 120 pieces of rolling stock and 14 locomotives were observed at the nearby Dong Dang transshipment point.

14. The 28 October photography also showed a probable rail-to-road transshipment point under construction near Ho-Kou, China, just across the border from Lao Cai, North Vietnam. The installation is served by two rail spurs off the Kunming-Hanoi rail line. Construction of such an installation may pre-
sage an increase in supply shipments via truck to
northwestern North Vietnam. Chinese engineers have
been developing the road network and logistical fa-
cilities in the border area for the past two years.

15. Railroad lines: The 28 October mission covered 100 percent of the Haiphong-Hanoi rail line,

-4-

~~No Foreign Dissem~~
~~TOP SECRET TRINE~~



~~TOP SECRET TRINE~~
~~No Foreign Dissem~~

75 percent of the Dong Dang-Hanoi line, 35 percent of the Kep-Thai Nguyen-Hanoi line, 20 percent of the Lao Cai-Hanoi line, and 10 percent of the Hanoi-Dong Hoi line.

16. Hanoi Thermal Power Plant: Photography of 28 October showed damage at and near the plant. A hole in the generator hall roof indicated a penetration and a possible internal detonation. Another hole in the generator hall roof--which had been repaired after the 21 August strike--has been reopened. A possible hit immediately north of the coal conveyor, entered the new boiler-house section. (This possible hit apparently did not detonate.) A crater was visible on the north boundary of the plant. About 35 civilian structures in the area surrounding the plant have been destroyed and 40 damaged. No smoke or steam from the plant was evident.

-5-

~~No Foreign Dissem~~
~~TOP SECRET TRINE~~



Title:	(EST PUB DATE) NORTH KOREA MISSION BX 6847
Abstract:	
Pages:	0011
Pub Date:	1/1/1968
Release Date:	7/17/2001
Keywords:	OXCART SR-71 BLACKBIRD BLACK SHIELD A- 12
Case Number:	F-2000-01388
Copyright:	0
Release Decision:	RIFPUB
Classification:	U



7 188



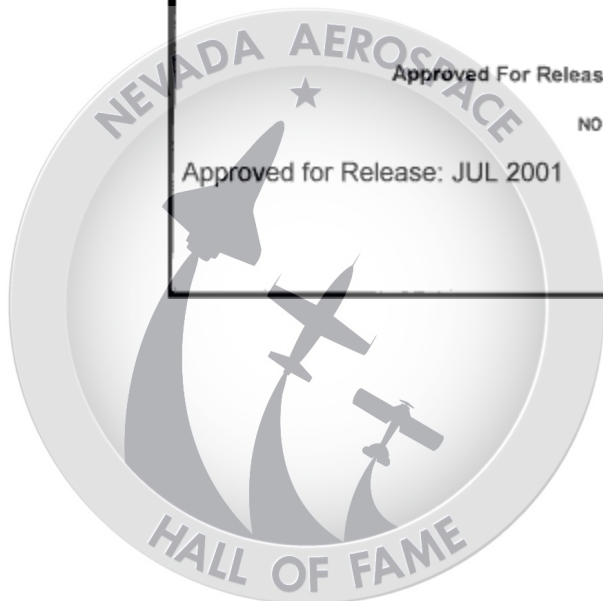
NORTH KOREA MISSION BX 6847

26 JANUARY 1968

HIGHLIGHTS

NPIC/R-17/68
JANUARY 1968

GROUP 1 EXCLUDED FROM
AUTOMATIC DOWNGRADING
AND DECLASSIFICATION



Approved For Release 2000/06/30 : CIA-RDP78B04560A006200010016-3

WARNING

This document contains information affecting the national defense of the United States, within the meaning of Title 18, sections 793 and 794, of the U.S. Code, as amended. Its transmission or revelation of its contents to or receipt by an unauthorized person is prohibited by law.

Approved For Release 2000/06/30 : CIA-RDP78B04560A006200010016-3



CORD PY	COPY NO.	PUB. DATE	LOCATION	MASTER	DATE RECEIVED	LOCATION					
DISPOSITION DATE(S) Approved For Release 2000/06/30 : CIA-RDP78B04560A006200010016-3											
T TO PAGES	DATE	CUT TO COPIES	DATE	STOCK COPIES DESTROYED	MINIMUM	MAXIMUM					
25	7-70					10					
T TO PAGES	DATE	CUT TO COPIES	DATE								
10	7-72										
T TO PAGES	DATE	MASTER	DATE								
0	7-74										
DATE		RECEIVED OR ISSUED	NUMBER OF COPIES			RECEIVED OR ISSUED			NUMBER OF COPIES		
DAY	YR.		REC'D	ISS'D	BAL	MO.	DAY	YR.	REC'D	ISS'D	BAL
29	68	Dist. Unit	51		51						
14	68	NPIC		1	50						
19	68	CS/OA		1	49						
26	68	NPIC		1	48						
22	71	INVENTORY			10						
23	73	Dist. # 10 copies	10		0						
Approved For Release 2000/06/30 : CIA-RDP78B04560A006200010016-3											

TITLE: NDTA/D-17/68
 DATE: Jan 1968
 SEC. CLASS: ~~S~~/FORN
 LOCATION: 505116-27 X



PREFACE

This report summarizes information derived from Black Shield Mission 6847, 26 January 1968 over North Korea. Additional details can be obtained from cabled reports disseminated by NPIC and the 67 RTS.

Recipients are cautioned that the scan of the photography has been accomplished in a short time and does not constitute a finished intelligence judgment. Future detailed analysis may result in additional information.

The mission covers the southern half of North Korea and the eastern tip of the Shantung Peninsula in Communist China. Interpretability of the photography is fair-to-good with approximately 90 percent cloud-free coverage over the land areas. One hundred eight of the 138 COMLREX targets fall within this coverage, although 2 are cloud covered. In addition, 3 new targets have been reported.



HIGHLIGHTS

Pueblo Anchored Offshore

25X1D

25X1D The USS Pueblo is anchored offshore in Changshwan bay at 39-19-
127-26-
2.4 nm ENE of Munchon Naval Base Wonsan. A motor torpedo boat
(P-6 PT) is moored alongside and a probable miscellaneous service craft
(YAG) is off the port beam. It cannot be determined whether the ship has
been damaged or if any dismantling has taken place.

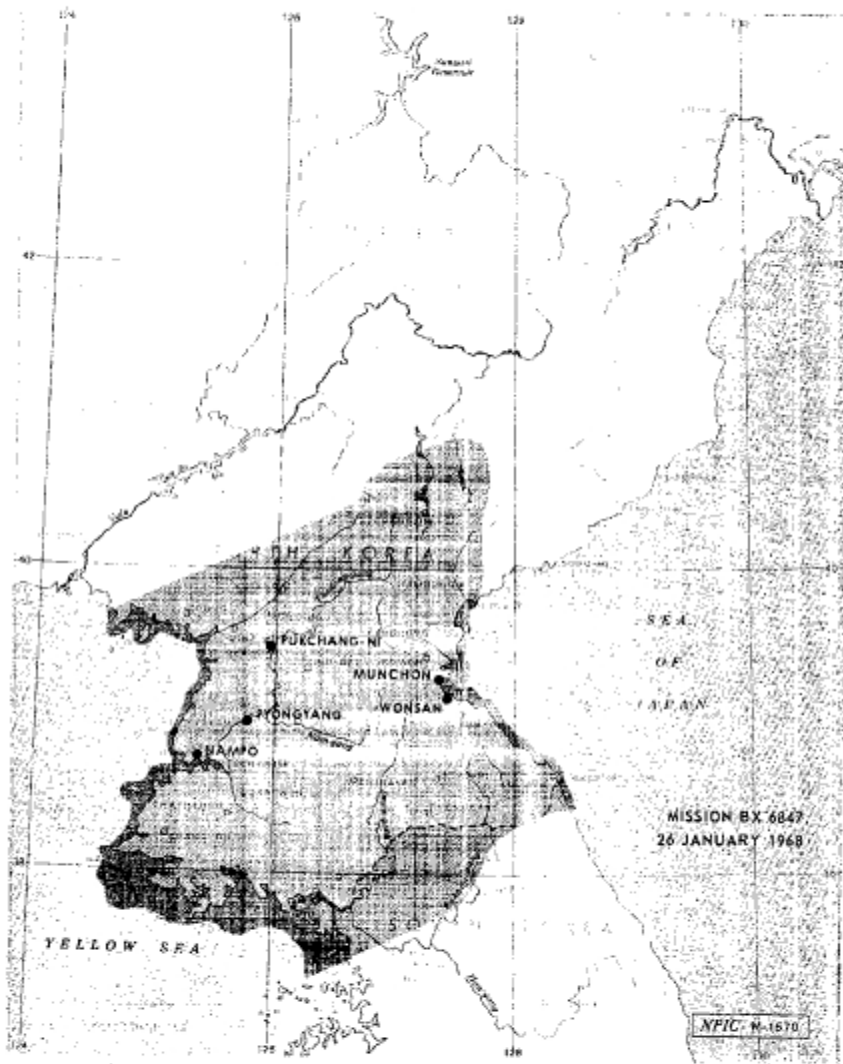
No evidence of salvage operations is observed in the vicinity of the
position (39-25N 127-54E) where special equipment may have been jettisoned
by the Pueblo.

Wonsan-Munchon Area Activity

The following Naval order of battle is observed in the area: Vessels
at the Munchon Naval Base include 2 fast patrol boats (Shershen PTF) new
to North Korean inventory, 2 small guided missile patrol boats (Komar PTG),
and 3 motor torpedo boats (P-2 PT). Vessels in the harbor include 3 Komar
PTG anchored off the west side of Hodo-pando peninsula, one minesweeper
(T-MSP(O)), and one submarine chaser (S.O.1 SC) anchored north of Sin-to
island. In addition, one probable submarine chaser (Yukto PTC) is underway
east of Hodo-pando heading SSE, and 2 additional Komar PTG are berthed at
Munchon Naval Base NE. Of the total of 7 Komar PTGs, 3 are observed on
photography for the first time.

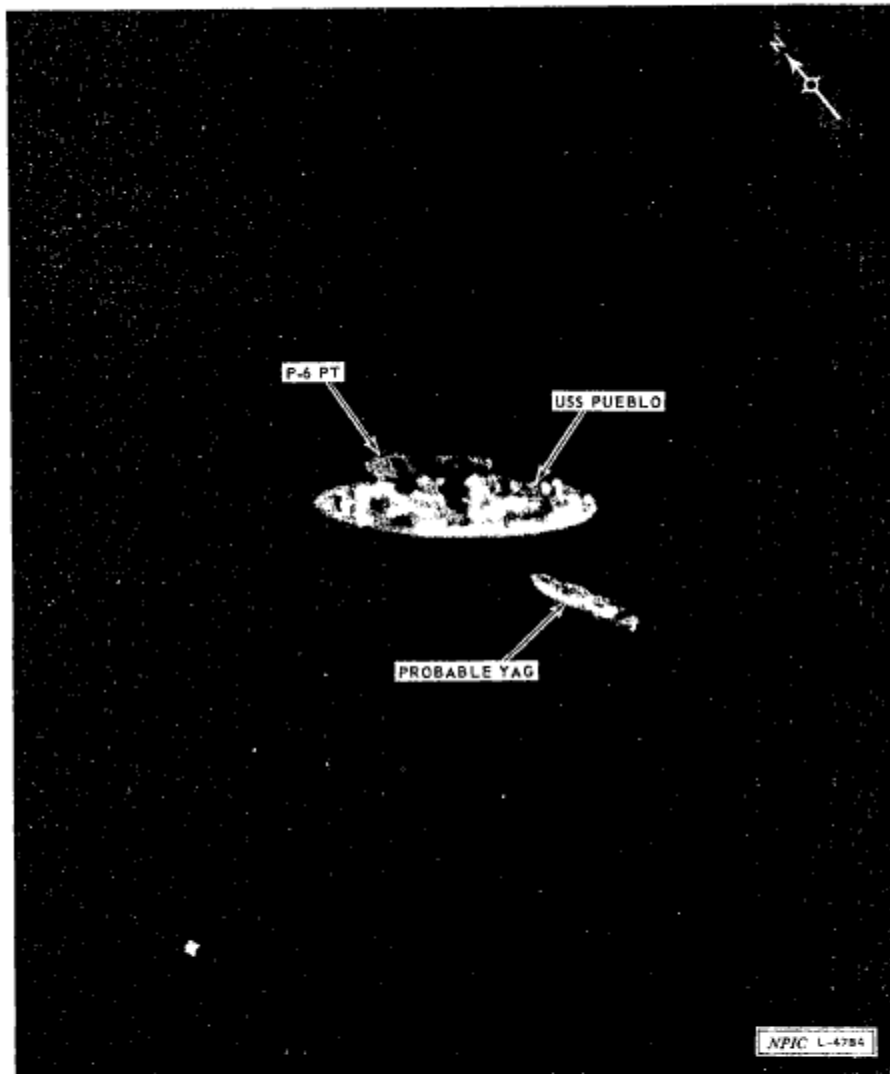
Two of the 3 SAM sites in this general area are observed, each with 6
launchers in place. At Wonsan SAM Site A10-2, two missiles are present;
at Hungdogi-dong SAM Site C22-2, missile presence cannot be determined.
Fifty-four FAGOT/FRESCO are at Wonsan Airfield.





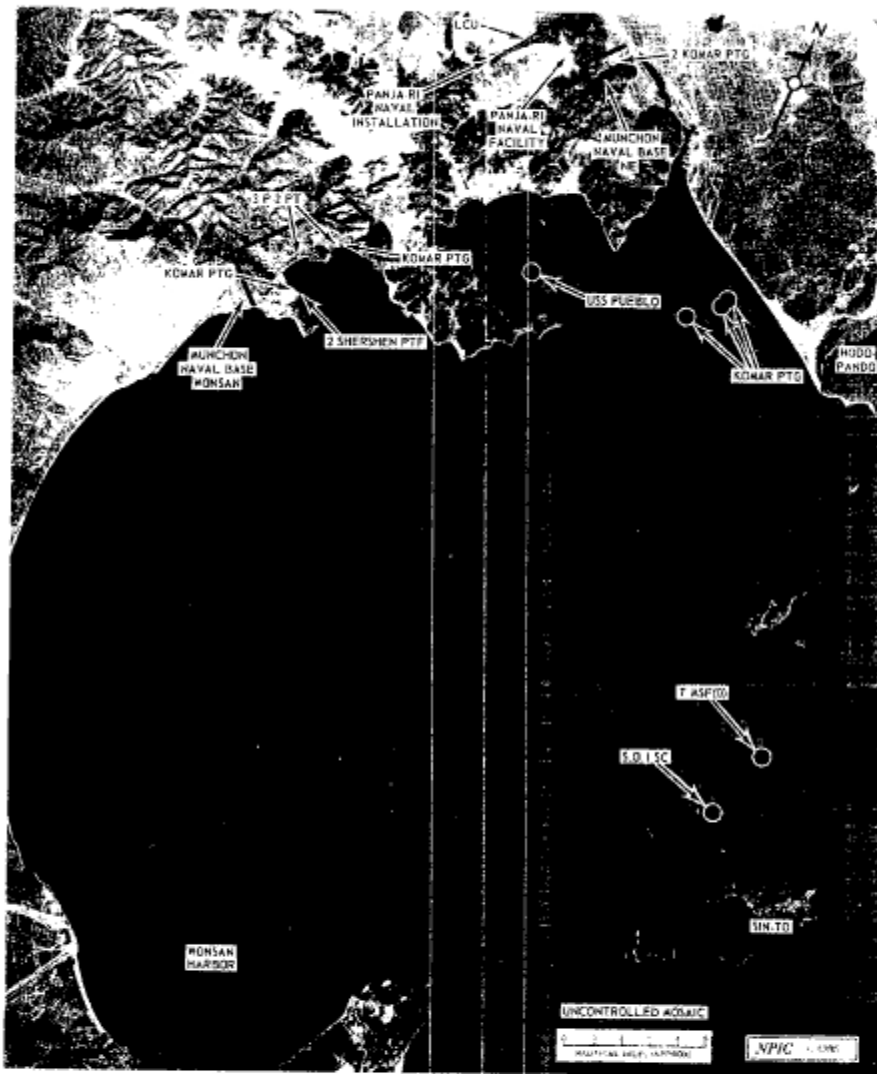
APPROXIMATE LAND AREA COVERED BY 80% CLOUD FREE PHOTOGRAPHY





USS PUEBLO





MUTUAL-ASSURED DEATH VIEW



Order of Battle

No major change is evident in the military posture of the North Korean armed forces either near the demilitarized zone or at the major military installations covered.

Order of battle at naval installations other than in the Wonsan-Manchon area shows no unusual activity or change.

Air order of battle at the major airfields reveals no significant change from previous coverage. However, 51 FRESCO shipping crates are observed at Pukchang-ni Airfield.

No significant activity or change is noted at the major urban complexes imaged on this mission.

No concentrations of military equipment or unusual activity are noted along major transportation lines.

SAM Sites

Of the 14 known SAM sites in North Korea, 12 are covered, one can be identified only, and one is not covered. All 12 sites are occupied and contain launchers in each of the six launch positions (at one site the launchers are probable). Nine sites have from one to three missiles each, and at three sites missile presence cannot be determined. Ten sites have FAN SONG radars but at two a definite identification of guidance equipment cannot be made.

No new SAM sites were observed in the preliminary scan.

Cruise Missile Activity

25X1D

Two cruise missile sites in the Nampo area are both unoccupied. In

25X1D

[REDACTED] The other is newly identified but was imaged on [REDACTED]. These are the only 25X1D two cruise missile sites currently identified in North Korea.

Thirty-two STYX (SS-N-2) crates are in the vicinity of Panje-ri Naval Facility, 3 nm NE of Manchon Naval Base Wonsan.



Approved For Release 2000/06/30 : CIA-RDP78B04560A006200010016-3
~~SECRET~~
NO FOREIGN DISSEM

Approved For Release 2000/06/30 : CIA-RDP78B04560A006200010016-3
~~SECRET~~
NO FOREIGN DISSEM



Title:	(EST PUB DATE) JUSTIFICATION FOR RETENTION F THE IDEALIST U-2 PROGRAM
Abstract:	
Pages:	0004
Pub Date:	1/1/1968
Release Date:	7/24/2001
Keywords:	OXCART SR-71 BLACKBIRD BLACK SHIELD A-12
Case Number:	F-2000-01388
Copyright:	0
Release Decision:	RIFPUB
Classification:	U



~~SECRET~~

MEMORANDUM FOR: Director, Office of Special Activities
SUBJECT: Justification for Retention of the IDEALIST
U-2 Program
REFERENCE:

1. Recently several formal documents and informal conversations have indicated that a very real possibility exists that the IDEALIST Program will be discussed at the November ExCom meeting. These discussions, sparked by either the BOB, the DOD, or both, will most likely examine the need for continuation of this Program. In fact, the BOB announced at both the 1967 and 1968 Budget Hearings that at the November 1968 ExCom meeting they would make a point of discussing the IDEALIST Program in depth, with the aim of determining whether the Program merits continuation. With indications of this type, it well behooves the Agency to be prepared to not only discuss its IDEALIST Program, but to have undeniable proofs that a very valid requirement still exists for continuation of this Program.

2. It can be assumed, that in these forthcoming discussions, the arguments advocating discontinuation of the IDEALIST Program, will be much the same as those used in the past. Indeed, some

~~SECRET~~



~~SECRET~~

Page 2

of these points were used successfully and effectively by BOB/DOD during the debates surrounding the life of the OXCART Program. The following depicts salient examples from these now familiar arguments:

a. The cost of the program exceeds the value of the returns derived from it.

b. The USAF could perform these reconnaissance tasks as well and at less expense to the Government.

c. There is no longer a need to differentiate between civilian and military pilots for reconnaissance missions.

d. Two units (CIA-SAC) means a duplication of costs and expenses.

e. The IDEALIST Program has, on an average, completed far less operational flying time and missions than the USAF, therefore the USAF is doing more productive work and should be given all the U-2 resources.

3. Undoubtedly, there are numerous other views in the same vein that could be brought to bear on this subject. It is not however, the intent of this paper to match argument for argument, nor to rehash the reasons for and against the military assumption of the IDEALIST Program. If, however, through lack of diligence

~~SECRET~~



~~SECRET~~

Page 3

and effort on our part, these roles and assets were to be lost by the Agency, the impact on the Intelligence Community would be immeasurable. Therefore, this paper will attempt to record only the advantages and adaptability of the IDEALIST Program to the U.S. Intelligence Community, and, thereby, positively show the program's ability to stand above any of the BOB/DOD contentions for its demise. There has to be sound assurances that a continuation of this Program will serve the best interests of the USA.

4. There is no escaping the fact that the U.S. Government, in the years to come, will have a continuing requirement for reconnaissance of denied territory which should be attributed to non-military resources. The missions and roles of the CIA U-2's have in the past, and indeed, will in the future, be entirely separate and different from any other U.S. reconnaissance aircraft, (including the SAC U-2's). The CIA U-2's are, simply stated, required to be capable of overflying denied territory in peacetime. A more formal definition would be the ability to successfully overfly denied territory with impunity in non-military aircraft flown by a bona fide civilian.

5. Peacetime overflights of denied territory dictate completely

~~SECRET~~



~~SECRET~~

Page 4

different sets of requirements for the aircraft systems configuration, the pilot used, the command and control of the mission, and the political approval mechanisms for the mounting for the mission. It is foregone knowledge that peacetime overflights of any "other country" require prior approvals for the mission by highest political elements of the U.S. Government. In order to merit the political risk involved, the "fool-proof" success of any mission must be virtually guaranteed to these upper levels of the U.S. Government. Therefore, prior to soliciting these approvals, considerable efforts must be expended to adjust the overall risk and to estimate the success factor for each IDEALIST U-2 flight.

6. Perfection requirements for these missions explain in part the additional cost and reduced number of IDEALIST Operational missions/flying hours. It is the conviction of these experienced in U-2 operations that development efforts over the past few years have in fact made the IDEALIST U-2 an exceptionally low risk, highly responsive and flexible reconnaissance vehicle. It further bears noting that CFA enjoys a recognized unique capability for constantly and promptly developing and adapting equipment, tactics, and operational procedures that insure lowest level of vulnerability for this overflight aircraft. IDEALIST has served in the development of many unique techniques for application of the U-2 reconnaissance system on a world-wide basis. This program possesses the capability of operating the U-2 from aircraft carriers, [REDACTED]

25X1X7

25X1X7

25X1X7

[REDACTED] and Release 2000/08/21 : CIA-RDP33-02415A000400290003-2
to crises situations anywhere in the world



Title:	(EST PUB DATE) NORTH KOREA MISSION BX 6847
Abstract:	
Pages:	0011
Pub Date:	1/1/1968
Release Date:	6/21/2001
Keywords:	OXCART SR-71 BLACKBIRD BLACK SHIELD A-12
Case Number:	EO-2000-00628
Copyright:	0
Release Decision:	RIFPUB
Classification:	U



7 188



NORTH KOREA MISSION BX 6847

26 JANUARY 1968

HIGHLIGHTS

NPIC/R-17/68
JANUARY 1968

GROUP 1 EXCLUDED FROM
AUTOMATIC DOWNGRADING
AND DECLASSIFICATION



Approved For Release 2000/06/30 : CIA-RDP78B04560A006200010016-3

WARNING

This document contains information affecting the national defense of the United States, within the meaning of Title 18, sections 793 and 794, of the U.S. Code, as amended. Its transmission or revelation of its contents to or receipt by an unauthorized person is prohibited by law.

Approved For Release 2000/06/30 : CIA-RDP78B04560A006200010016-3



CORD PY	COPY NO.	PUB. DATE	LOCATION	MASTER	DATE RECEIVED	LOCATION								
DISPOSITION DATE(S) Approved For Release 2000/06/30 : CIA-RDP78B04560A006200010016-3														
T TO PIES	25	DATE 7-70	CUT TO COPIES	DATE	STOCK COPIES DESTROYED	MINIMUM MAXIMUM 10								
T TO PIES	10	DATE 7-72	CUT TO COPIES	DATE										
T TO PIES	0	DATE 7-74	MASTER	DATE										
DATE		RECEIVED OR ISSUED	NUMBER OF COPIES			DATE			RECEIVED OR ISSUED			NUMBER OF COPIES		
DAY	YR.		REC'D	ISS'D	BAL	MO.	DAY	YR.				REC'D	ISS'D	BAL
29	68	Dist. Unit	51		51									
14	68	NPIC		1	50									
19	68	CS/OA		1	49									
26	68	NPIC		1	48									
22	71	INVENTORY			10									
23	73	Dist. # 10 copies	10		0									
Approved For Release 2000/06/30 : CIA-RDP78B04560A006200010016-3														

TITLE: NPTA/D-17/68
 SEC. CLASS: ~~S~~/FORN
 LOCATION: 505116-27 X



PREFACE

This report summarizes information derived from Black Shield Mission 6847, 26 January 1968 over North Korea. Additional details can be obtained from cabled reports disseminated by NPIC and the 67 RTS.

Recipients are cautioned that the scan of the photography has been accomplished in a short time and does not constitute a finished intelligence judgment. Future detailed analysis may result in additional information.

The mission covers the southern half of North Korea and the eastern tip of the Shantung Peninsula in Communist China. Interpretability of the photography is fair-to-good with approximately 90 percent cloud-free coverage over the land areas. One hundred eight of the 138 COMLREX targets fall within this coverage, although 2 are cloud covered. In addition, 3 new targets have been reported.



HIGHLIGHTS

Pueblo Anchored Offshore

25X1D

25X1D The USS Pueblo is anchored offshore in Changshwan bay at 39-19-
127-26-
2.4 nm ENE of Munchon Naval Base Wonsan. A motor torpedo boat
(P-6 PT) is moored alongside and a probable miscellaneous service craft
(YAG) is off the port beam. It cannot be determined whether the ship has
been damaged or if any dismantling has taken place.

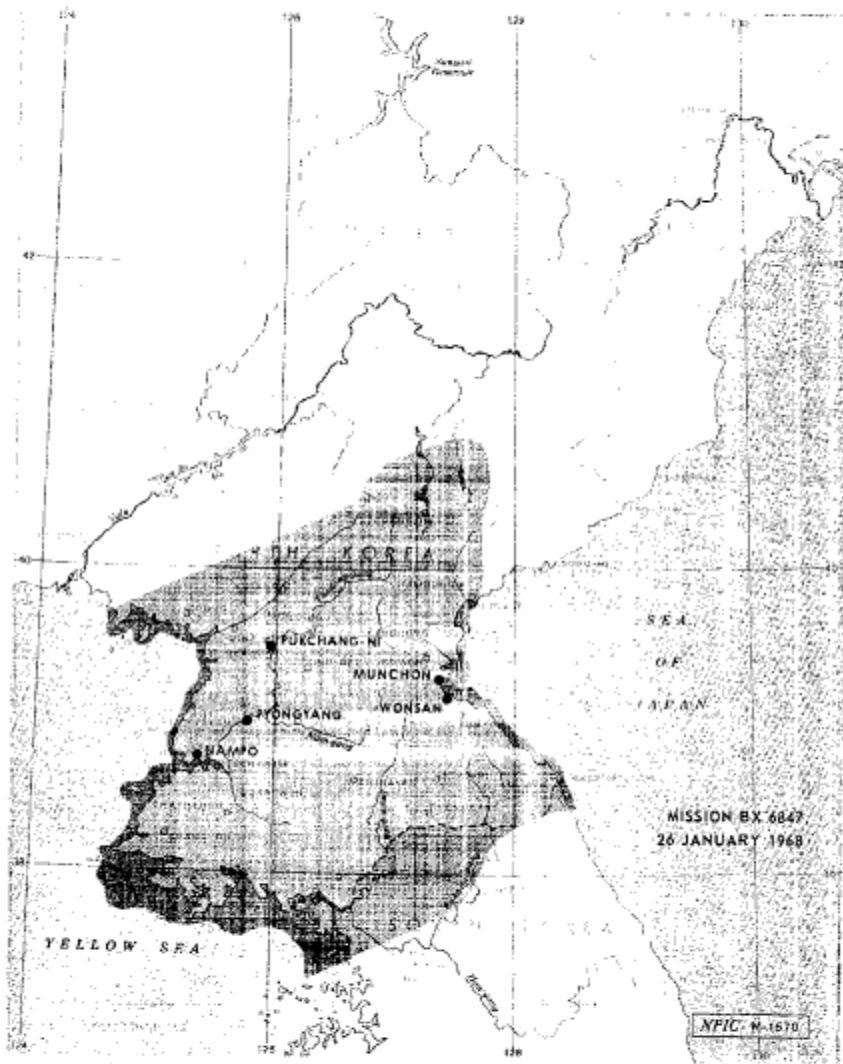
No evidence of salvage operations is observed in the vicinity of the
position (39-25N 127-54E) where special equipment may have been jettisoned
by the Pueblo.

Wonsan-Munchon Area Activity

The following Naval order of battle is observed in the area: Vessels
at the Munchon Naval Base include 2 fast patrol boats (Shershen PTF) new
to North Korean inventory, 2 small guided missile patrol boats (Komar PTG),
and 3 motor torpedo boats (P-2 PT). Vessels in the harbor include 3 Komar
PTG anchored off the west side of Hodo-pando peninsula, one minesweeper
(T-MSP(O)), and one submarine chaser (S.O.1 SC) anchored north of Sin-to
Island. In addition, one probable submarine chaser (Yukto PTC) is underway
east of Hodo-pando heading SSE, and 2 additional Komar PTG are berthed at
Munchon Naval Base NE. Of the total of 7 Komar PTGs, 3 are observed on
photography for the first time.

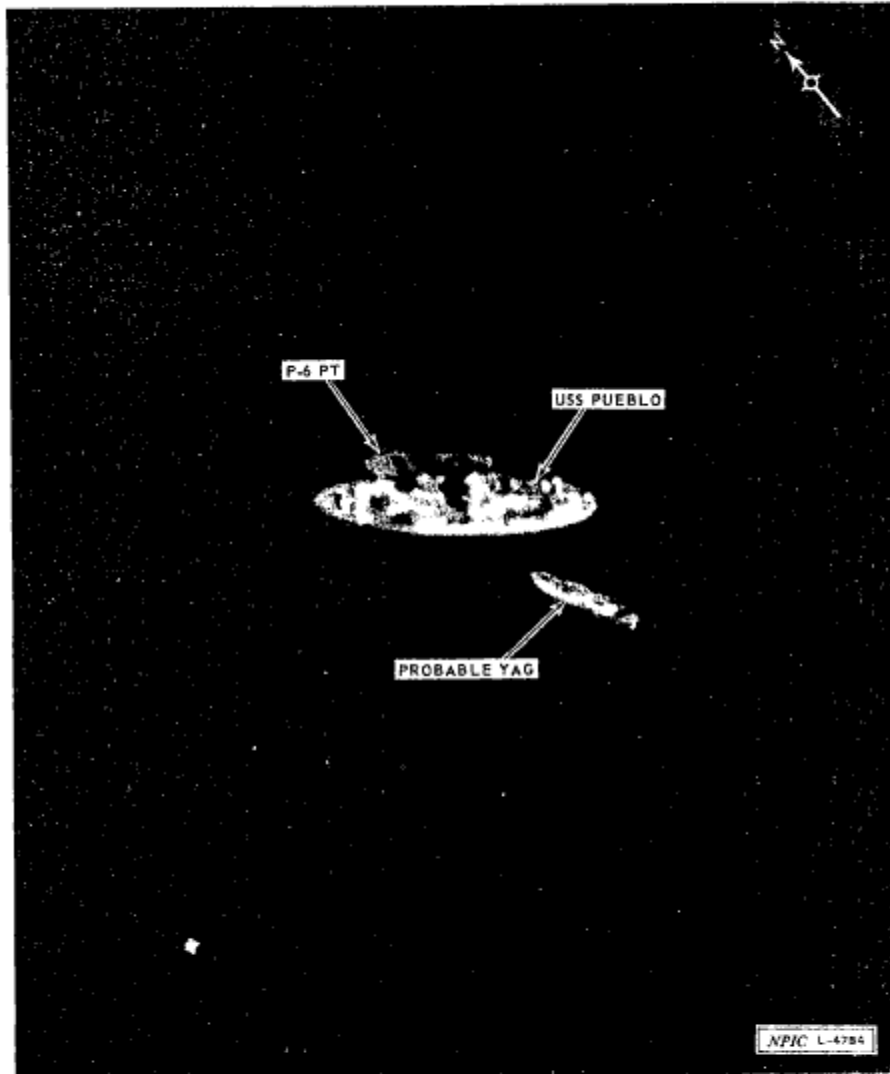
Two of the 3 SAM sites in this general area are observed, each with 6
launchers in place. At Wonsan SAM Site A10-2, two missiles are present;
at Hungdogi-dong SAM Site C22-2, missile presence cannot be determined.
Fifty-four FAGOT/FRESCO are at Wonsan Airfield.





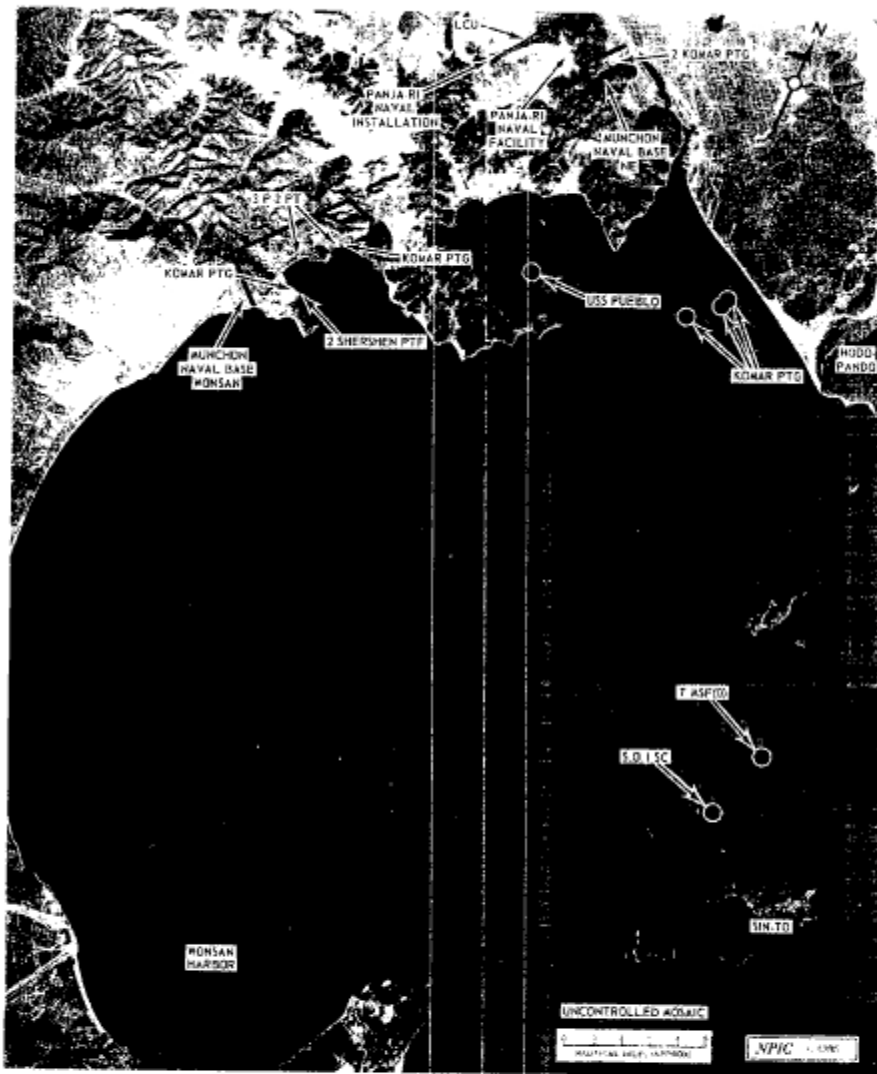
APPROXIMATE LAND AREA COVERED BY 80% CLOUD FREE PHOTOGRAPHY





USS PUEBLO





MUTUAL-ASSURED DEATH VIEW



Order of Battle

No major change is evident in the military posture of the North Korean armed forces either near the demilitarized zone or at the major military installations covered.

Order of battle at naval installations other than in the Wonsan-Manchon area shows no unusual activity or change.

Air order of battle at the major airfields reveals no significant change from previous coverage. However, 51 FRESCO shipping crates are observed at Pukchang-ni Airfield.

No significant activity or change is noted at the major urban complexes imaged on this mission.

No concentrations of military equipment or unusual activity are noted along major transportation lines.

SAM Sites

Of the 14 known SAM sites in North Korea, 12 are covered, one can be identified only, and one is not covered. All 12 sites are occupied and contain launchers in each of the six launch positions (at one site the launchers are probable). Nine sites have from one to three missiles each, and at three sites missile presence cannot be determined. Ten sites have FAN SONG radars but at two a definite identification of guidance equipment cannot be made.

No new SAM sites were observed in the preliminary scan.

Cruise Missile Activity

25X1D

Two cruise missile sites in the Nampo area are both unoccupied. In

25X1D

[REDACTED] The other is newly identified but was imaged on [REDACTED]. These are the only 25X1D two cruise missile sites currently identified in North Korea.

Thirty-two STYX (SS-N-2) crates are in the vicinity of Panje-ri Naval Facility, 3 nm NE of Manchon Naval Base Wonsan.



Approved For Release 2000/06/30 : CIA-RDP78B04560A006200010016-3
~~SECRET~~
NO FOREIGN DISSEM

Approved For Release 2000/06/30 : CIA-RDP78B04560A006200010016-3
~~SECRET~~
NO FOREIGN DISSEM



(EST PUB DATE) SOUTHEAST ASIS ACTIVITY REPORT - NORTH VIETNAM LOGISTICS ACTIVIT

Title:	(EST PUB DATE) SOUTHEAST ASIS ACTIVITY REPORT - NORTH VIETNAM LOGISTICS ACTIVIT
Abstract:	
Pages:	0047
Pub Date:	2/1/1968
Release Date:	7/17/2001
Keywords:	OXCART SR-71 BLACKBIRD BLACK SHIELD A-12
Case Number:	F-2000-01388
Copyright:	0
Release Decision:	RIFPUB
Classification:	U



187

Approved For Release 2000/06/30 : CIA-RDP78B04560A006200010028-0
NO FOREIGN DISSEM [REDACTED] 25X1C

PHOTOGRAPHIC INTERPRETATION REPORT



SOUTHEAST ASIA
ACTIVITY REPORT

NORTH VIETNAM
LOGISTICS ACTIVITY
1967-68 TRUCE PERIODS

NPIC/R-30/68
FEBRUARY 1968

GROUP 1 EXCLUDED FROM
AUTOMATIC DOWNGRADING
AND DECLASSIFICATION

Approved For Release 2000/06/30 : CIA-RDP78B04560A006200010028-0
NO FOREIGN DISSEM [REDACTED] 25X1C

Approved for Release: JUL 2001



Approved For Release 2000/06/30 : CIA-RDP78B04560A006200010028-0

WARNING

This document contains information affecting the national defense of the United States, within the meaning of Title 18, sections 793 and 794, of the U.S. Code, as amended. Its transmission or revelation of its contents to or receipt by an unauthorized person is prohibited by law.

Approved For Release 2000/06/30 : CIA-RDP78B04560A006200010028-0



RECORD COPY	COPY NO.	PUB. DATE	LOCATION	MASTER	DATE RECEIVED	LOCATION												
Approved For Release 2000/06/30 : CIA-RDP78B04560A006200010028-0																		
CUT TO COPIES	25	DATE 7-70	CUT TO COPIES	DATE	COPIES DESTROYED													
CUT TO COPIES	10	DATE 7-72	CUT TO COPIES	DATE														
CUT TO COPIES	0	DATE 7-74	MASTER	DATE														
DATE		RECEIVED OR ISSUED			NUMBER OF COPIES		DATE		RECEIVED OR ISSUED			NUMBER OF COPIES						
NO.	DAY	YR.	REC'D	ISS'D	BAL	NO.	DAY	YR.	REC'D	ISS'D	BAL	NO.	DAY	YR.	REC'D	ISS'D	BAL	
2	29	68			51													
	10	11									1							
	12	68									1							
	7	69									4							
	8	69									1							
	1	22																
	8	32									10							
25X1C																		
Approved For Release 2000/06/30 : CIA-RDP78B04560A006200010028-0																		

TITLE NPIC/R-30/68 Feb. 1968. [REDACTED] 505116 X



PREFACE

This report is a summary of selected information on transportation and infiltration activity in southeast Asia as reported by NPIC during the period indicated on the cover. Those lines of communication and associated facilities which support communist insurgency in Laos and South Vietnam are emphasized.

Items are numbered and arranged according to location from north to south. Annotated maps of varying scales have been included to assist the reader in locating the items. Each large-scale map depicts all motorable roads photographically confirmed by NPIC unless otherwise indicated.

Missions, mission dates, frames, and NPIC cable and briefing board references are listed after each item, as appropriate.



INTRODUCTION

25X1D This report summarizes the logistics activity in the Panhandle area of
North Vietnam during the [REDACTED] truce periods. As in the past, the North
25X1D Vietnamese fully exploited the 36-hour U.S. bombing cessations during the
Christmas [REDACTED] and New Year [REDACTED] 25X1D
25X1D [REDACTED] Truce Periods and, to a lesser extent,
the Tet Truce Period [REDACTED] 25X1D

As indicated by the accompanying map, there were significant photogra-
phic gaps during each of the periods. However, the coverage was complete
enough to permit an assessment of the activity and a comparison of the
25X1D periods. Reference is also occasionally made to [REDACTED] of 25X1D
It is felt that this mission reflected a normal daylight
activity level for this area of North Vietnam.

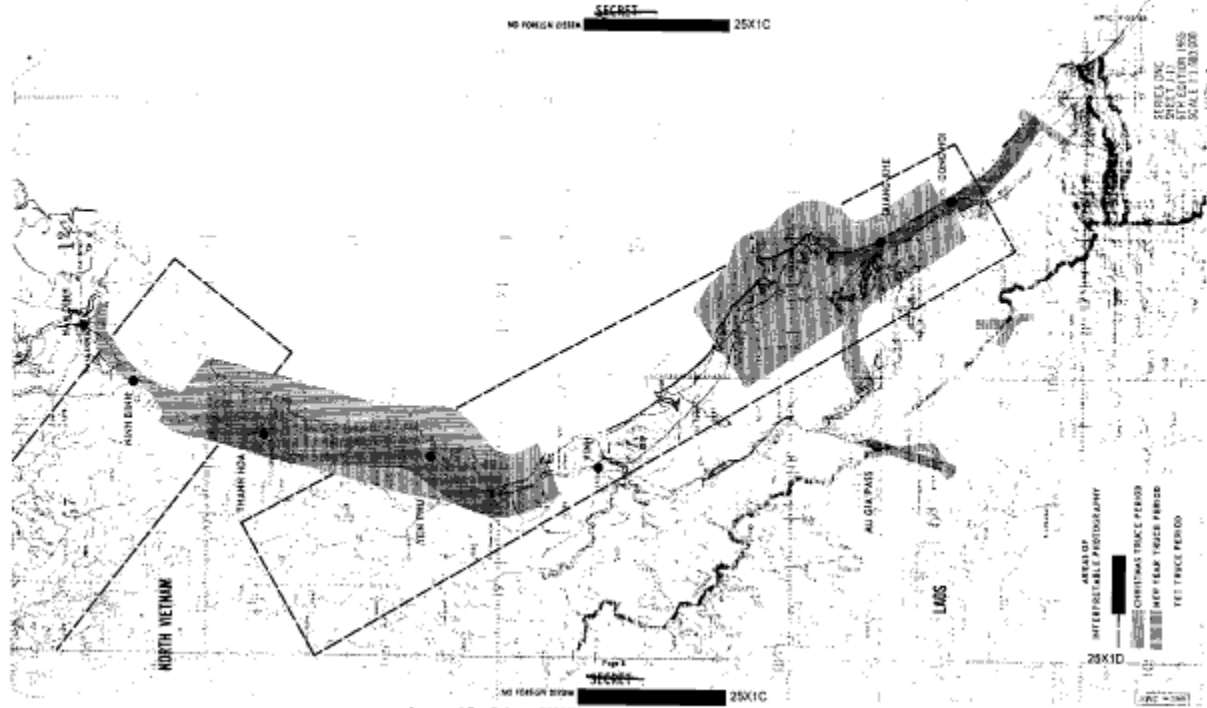
To facilitate a comparison of the logistics activity, the report has
been divided into the following sections: Vehicular Activity, pp 4-12;
Quang Khe Transshipment Points, pp 13-19; Song Troc (River) Transshipment
Points, pp 20-23; Viet Yen Transshipment Point, pp 24-25; Yen Phu Area
Logistics Activity, pp 26-33; and Railroad Activity, pp 34-39. Except for
those craft observed at transshipment points, no waterborne activity could
be associated with the southern movement of supplies during these periods.

25X1D Tables of comparative vehicular activity during each of the truce
periods have been included in the appendix. These totals are not intended
as precise vehicle counts and should be used only for comparison purposes.
While it is doubtful that any convoys or major concentrations of vehicles
were successfully concealed on [REDACTED] individual vehicles are extremely
difficult to detect on Black Shield photography in areas of dense vegeta-
tion or along tree-lined routes. It is also logical to assume that some
duplicate "sightings" occurred during the truce periods, although the total
effect was minimized by the small number of missions and amount of overlap.

Page 2



SECRET
NO FOREIGN DISSEM 25X1C



Page 1
NO FOREIGN DISSEM 25X1C



~~SECRET~~

NO FOREIGN DISSEM

25X1C

Vehicle Activity

Identifiable photographic coverage during the Christmas and New Year Truce Periods was generally limited to the coastal routes south of Thud Bay, directly south LA. Although there were significant photographic gaps -- partly attributable to poor weather conditions -- in the areas of the depressed inland routes carrying the logistics out in Laos (Routes 5, 101, 110, and 127) and along a 400-mile coastal segment in the vicinity of Vinh, there were 1030 and 978 vehicle sightings during these periods, respectively. In contrast, only 157 vehicles were identified in a much larger area of [redacted] (see map, page 3).

25X1D

As suggested by the examples of vehicular activity included herein (Figures 1-6, 10), over half of the vehicles sighted during both periods were in transit on Route 1A between 19-00Z and 25-00Z. Contrary to the traffic pattern indicated by these examples, vehicular activity generally consisted of individual or scattered groups of trucks rather than convoys. Observations were frequently observed at river crossings, however, where such the obvious precaution was necessary to maintain a smooth flow of the high-volume traffic.

The majority of the vehicles sighted were conventional 3 1/2-ton cargo trucks, although numerous sub-compact trucks were also observed. Most of the cargo beds were canvas-covered, especially on reinforced handles. Vehicle cargo appeared to be tanks of material in 55-gallon drums or packaged goods. Many of the trucks also carried either VCL drums or a single large VCL storage tank, the latter probably serving the Ho Chi Minh Trail.

Except for the canvas-covered beds, there was little or no attempt to camouflage the vehicles or their movement. Conventional trucks were rarely camouflaged and the wooden frames which are frequently erected over the cab and hood were without the customary slits.

The vehicular activity observed during the Truce Period by sharply contrasted with that of the Christmas and New Year Truce. There were only 100 vehicles sighted during this period and most of them were parked in cities and villages. The drastic reduction in sightings can be attributed to [redacted]

25X1D

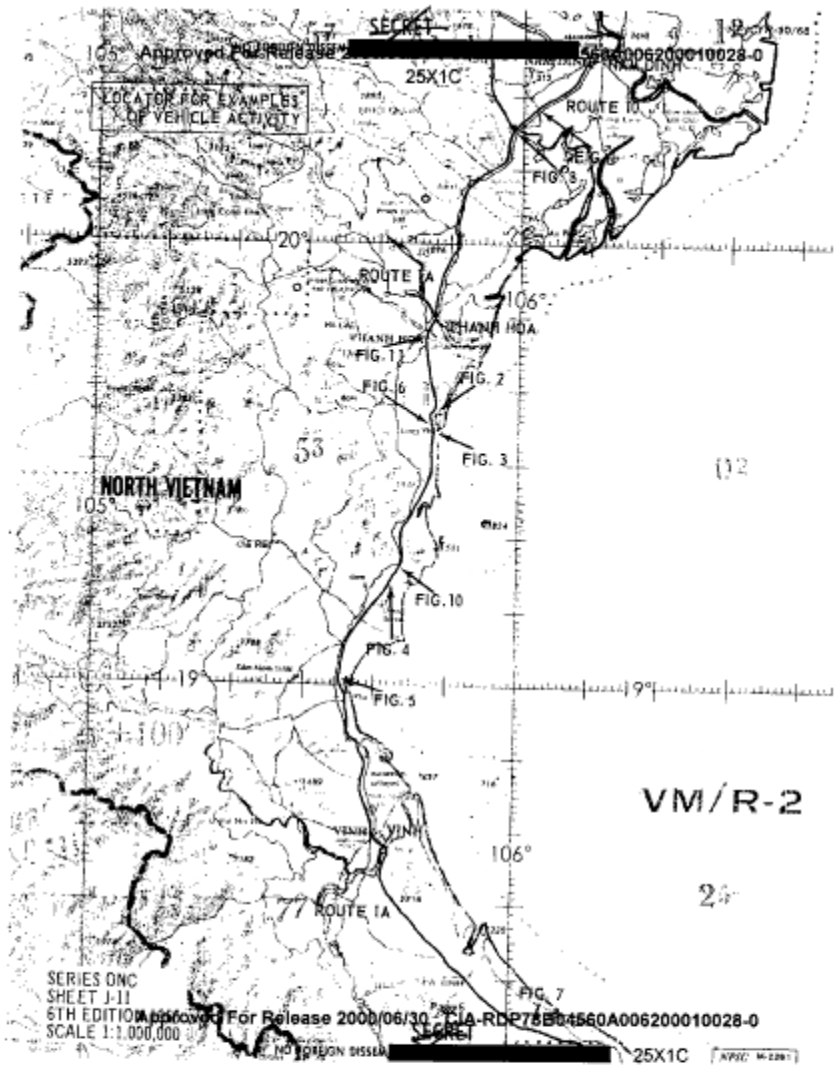
Page 1

~~SECRET~~

NO FOREIGN DISSEM

25X1C





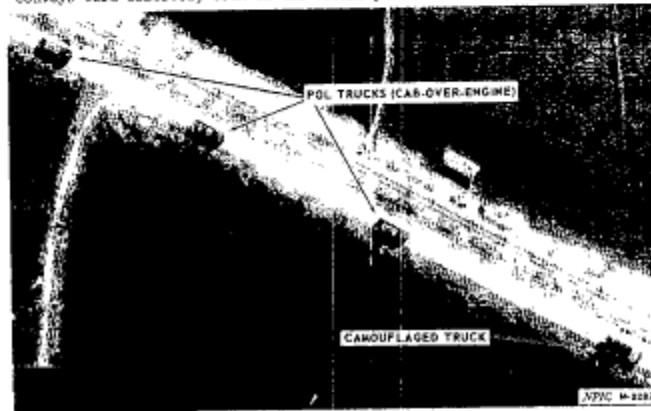
As bombing operations continued south of Vinh, a normal daylight vehicular pattern was maintained there during the Tet Period. Only 11 moving vehicles were sighted south of Vinh as compared to approximately 100 and 165 during the Christmas and New Year Periods, respectively. (It should also be noted that a greater area was covered by interpretable

25X1D [REDACTED] 25X1D

Only 1 vehicle was observed on Route 15 north of the Mu Gia Pass during this year's Tet Period as compared to approximately 200 during the 2-day Tet Bruce [REDACTED] (NPIC Briefing Board L-2754). However, in spite of the potential air strikes, road repair/maintenance was underway during daylight hours both prior to and during Tet (Figure 9). This perhaps reflected an urgency to keep open the most important logistics route into Laos.

As indicated above, there was relatively little vehicular movement observed even north of Vinh. Isolated instances of abnormal preparations for vehicular movement were noted, i.e., the positioning of a temporary bridge at Minh Binh during daylight hours (Figure 8); but only 2 small convoys were observed, both in the vicinity of Thanh Hoa (Figure 11).

25X1D



25X1D

FIGURE 1. VEHICLE ACTIVITY, ROUTE 10, NORTH VIETNAM (20-19N 106-01E)

Page 6



NO FOREIGN DISSEM ~~SECRET~~ 25X1C

REF ID: A61618

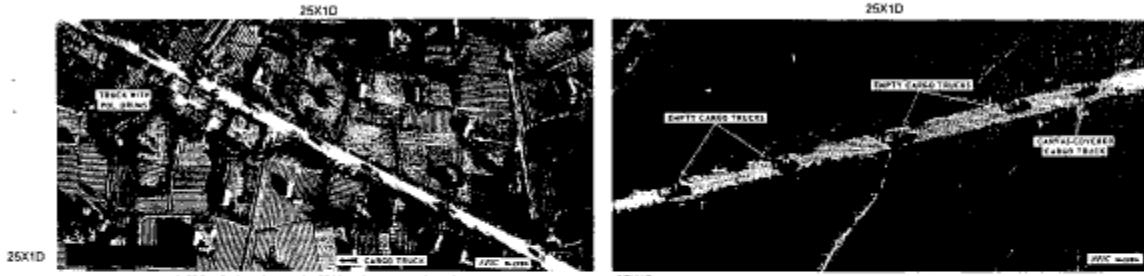


FIGURE 2. VEHICLE ACTIVITY, ROUTE 1A, NORTH VIETNAM (17-10N 105-40E)

FIGURE 3. VEHICLE ACTIVITY, ROUTE 1A, NORTH VIETNAM (17-10N 105-47E)



FIGURE 4. VEHICLE ACTIVITY, ROUTE 1A, NORTH VIETNAM (17-10N 105-48E)

Page 1

NO FOREIGN DISSEM ~~SECRET~~ 25X1C



NO FOREIGN DISSEM **SECRET** 25X1C

25X1D

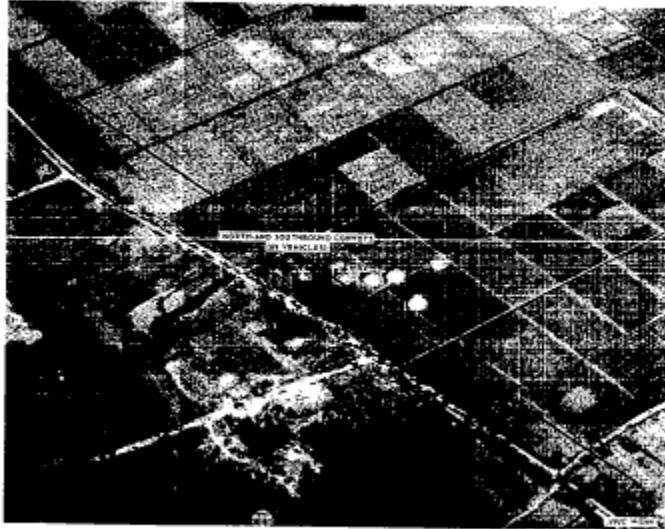


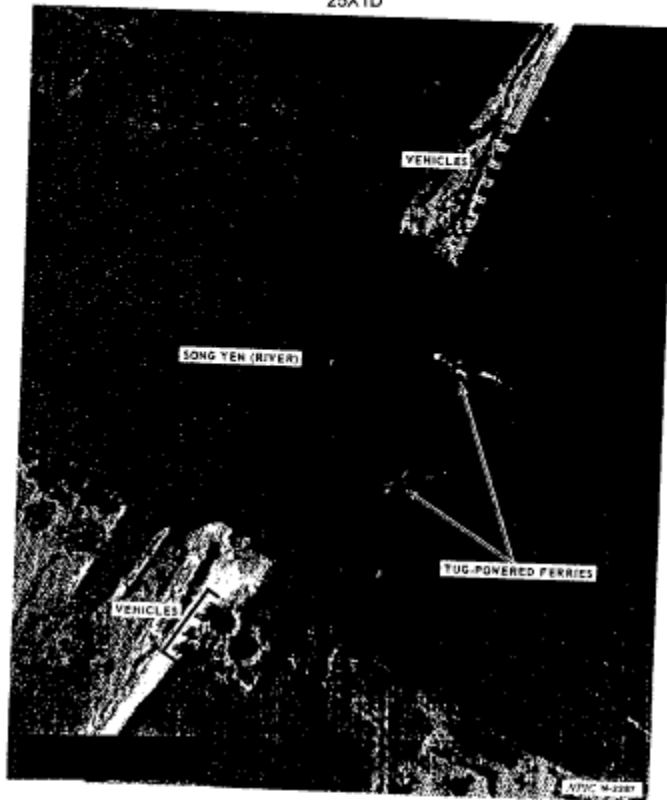
FIGURE 8. VEHICLE ACTIVITY, ROUTE 1A, NORTH WYANNA (FROM ISLIDE)

Page 4

NO FOREIGN DISSEM **SECRET** 25X1C



25X1D



25X1D

FIGURE 6. RIVER CROSSING, PHUNG CAT, NORTH VIETNAM (19-35N 105-47E)

Page 9



25X1D



25X1D

FIGURE 7. PARKED VEHICLES, HA TINH AREA, NORTH VIETNAM (18-12N 106-08E)

Page 12



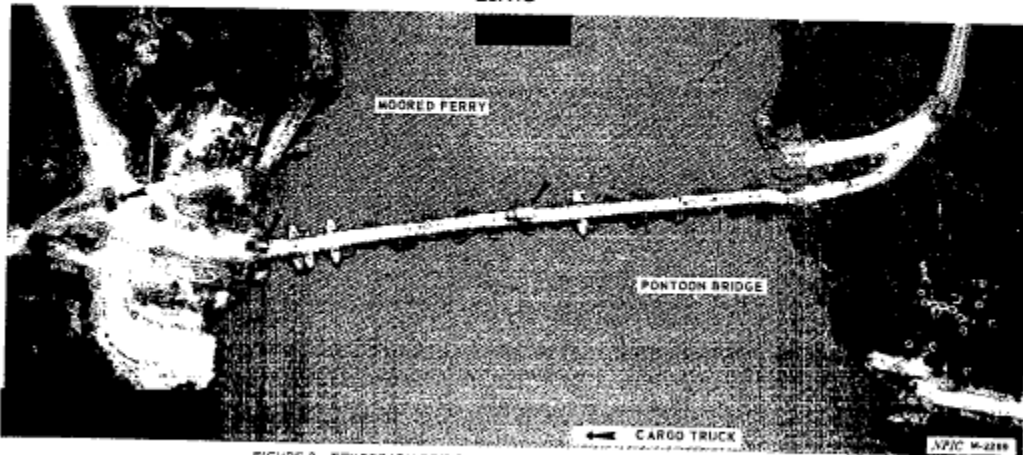
SECRET

NO FOREIGN DISSEM

25X1C

NPIC/R-30/68

25X1D



25X1D

25X1D

FIGURE 8. TEMPORARY BRIDGE, NINH BINH, NORTH VIETNAM (20-15N 105-59E)

25X1D



25X1D

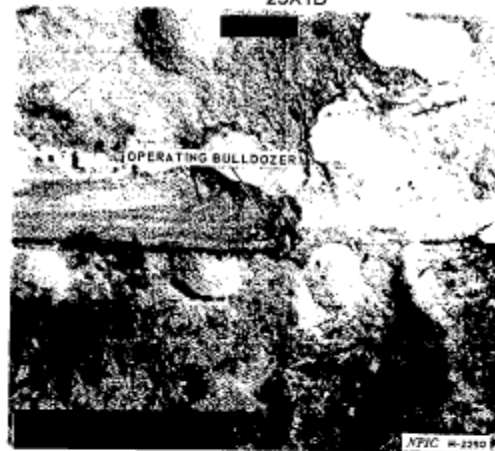


FIGURE 9. ROAD REPAIR/IMPROVEMENT, ROUTE 15, NORTH VIETNAM

25X1D

Page 11

SECRET

NO FOREIGN DISSEM

25X1C



SECRET

NO FOREIGN DISSEM

25X1C

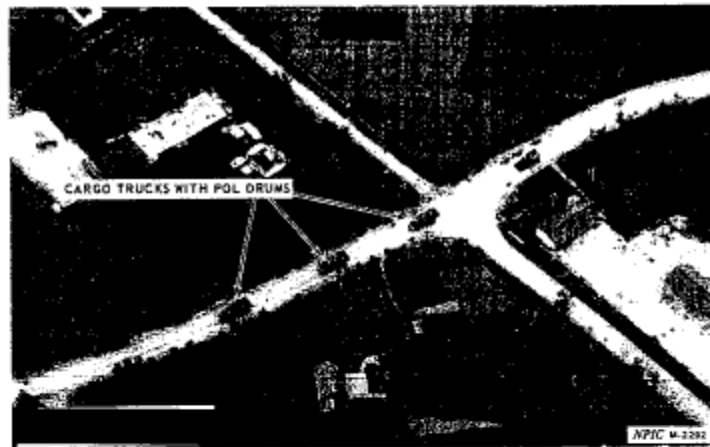
25X1D



25X1D

FIGURE 10. VEHICLE ACTIVITY, ROUTE 1A, NORTH VIETNAM (19-16N 105-43E)

25X1D



25X1D

FIGURE 11. VEHICLE ACTIVITY, THANH HOA AREA, NORTH VIETNAM (19-48N 105-05E)

Page 12

SECRET

NO FOREIGN DISSEM



Quang Khe Transshipment Points

The Quang Khe Transshipment Points once again provided the most vivid example of North Vietnamese exploitation of the U.S. bombing cessation during the Christmas and New Year Truce Periods. For the second year in a row, the north and south banks of the Song Giang (river) in the vicinity of the destroyed Quang Khe naval facilities erupted in a frenzy of transshipping activity. Unlike the Tet Truce Period when major logistics craft (including the first sightings of the SL-1 in North Vietnam) were involved, this year's activity was generally limited to the ferrying of supplies across the Song Giang by small and medium-sized sampans. However, there was no appreciable diminution in the overall levels of activity.

25X1D

Three transshipment points, 1 on the north bank and 2 on the south, were utilized during the 2 truce periods (see accompanying map). Extensive preparation was required for the use of Point No. 2 since the causeway leading to Route 1A had been heavily damaged. Figure 12 depicts the progression of activity: 1) the damaged causeway and inactive transshipment point on [redacted] 2) the off-loading and stacking of supplies prior to 1200 hours on [redacted] and 3) the column of vehicles waiting to be loaded at 1800 hours on [redacted]

25X1D
25X1D



25X1D The condition of the causeway is particularly interesting in this photographic sequence. The causeway had been made serviceable prior to ██████████ by repairing the damaged portions and substituting improved fords for those segments which had been completely destroyed. There was a marked deterioration of the causeway by the afternoon of the ██████████ 25X1D probably resulting from the extremely high volume of traffic during the day.

Transshipment Point No. 3, also on the south bank, exhibited relatively little activity during the Christmas period. At the same time 25X1D Point No. 2 was photographed on the morning of the ██████████ (Figure 12), the activity at Point No. 3 was limited to 1 sampen beached adjacent to several small stacks of supplies and personnel loading a single cargo truck. The deterioration of the causeway leading from Point No. 2 was not repaired prior to the New Year Truce, however, and Point No. 3 was the only transshipment point in use on the south bank during that period.

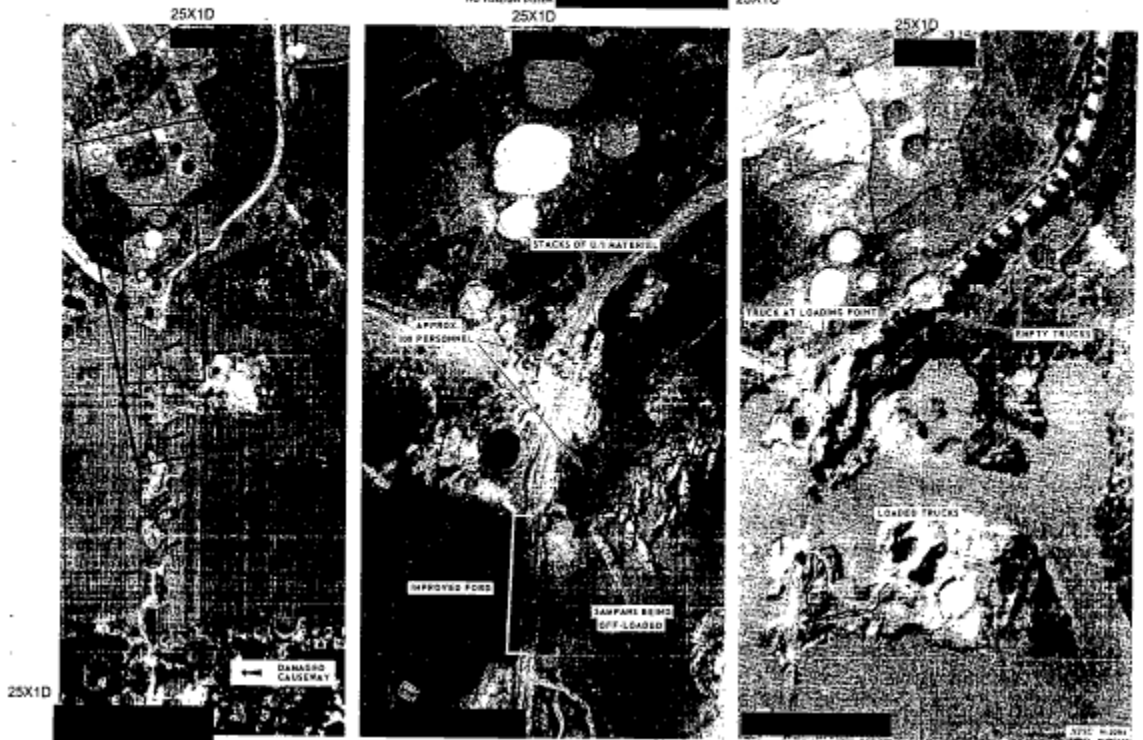
25X1D Transshipment Point No. 1, on the north bank of the Song Giang, probably provides the best example of the relative activity during all 3 truce periods. Figure 13 depicts a portion of the approximately 70 sampens, 250 personnel, and 6 cargo trucks involved in transshipping on the morning of ██████████ transshipment had been completed at this point by 1800 hours (Figure 1A). A comparable level of transshipping took place again during the New Year Truce Period (Figure 15), but the failure to suspend air strikes during Tet was reflected in the normal inactivity of ██████████ (Figure 16).

25X1D



~~SECRET~~

REF ID: A66666



25X1D FIGURE 12. TRANSHAYNHY POINT NO. 2 QUANG KHE, NORTH VIETNAM

Page 13

~~SECRET~~



SECRET

25X1C

NO FOREIGN DISSEM

FORM 4-75 34

25X1D



25X1D

FIGURE 13. TRANSMISSION POINT NO. 1, QUANG BINH, NORTH VIETNAM

Page 13

SECRET

NO FOREIGN DISSEM

25X1C



25X1D



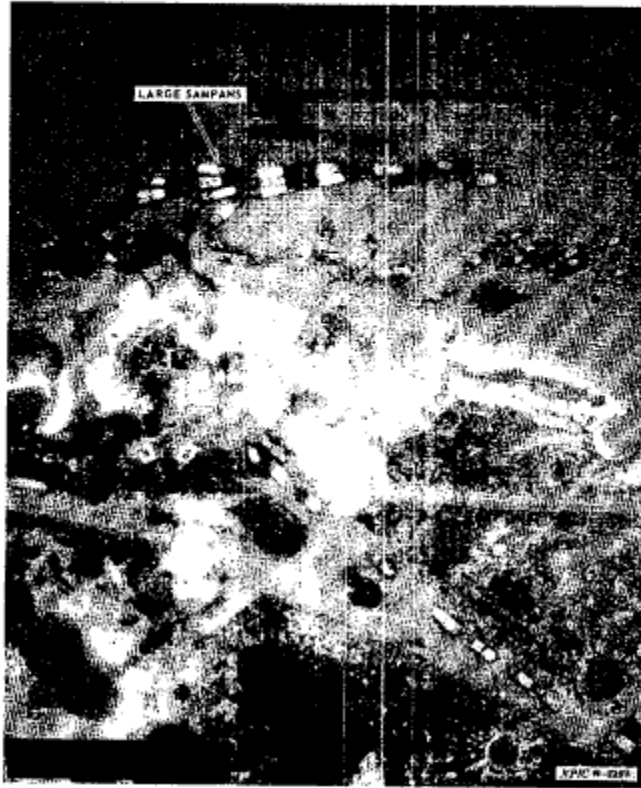
25X1D

FIGURE 14. TRANSHIPMENT POINT NO. 1 QUANG KHE, NORTH VIETNAM

Page 17



25X1D



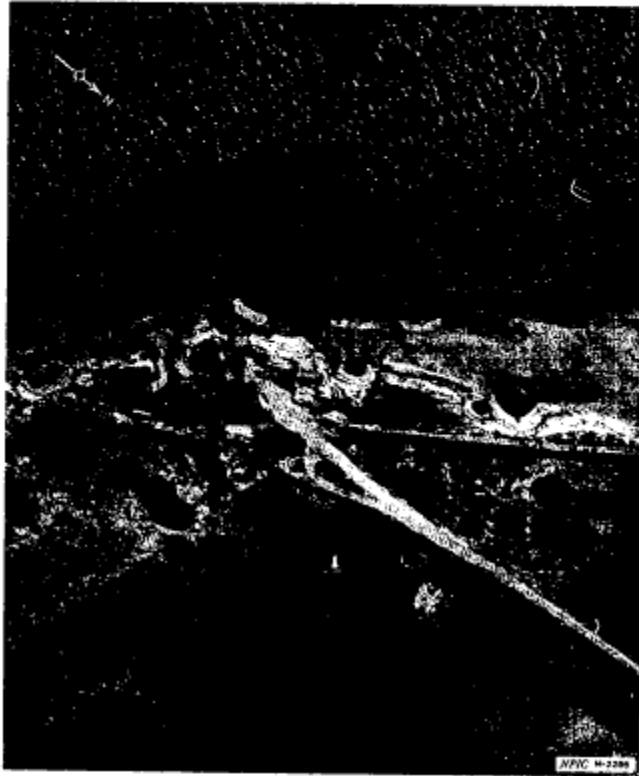
25X1D

FIGURE 15. TRANSHIPMENT POINT NO. 1 QUANG KHE, NORTH VIETNAM

Page 11



25X1D



25X1D

FIGURE 16. TRANSHIPMENT POINT NO. 1 (QUANG KHE, NORTH VIETNAM)

Page 19



Song Troc (River) Transshipment Points

The extensive amount of supplies stockpiled at 2 transshipment and storage facilities on the Song Troc (river), 4.5 nm west-southwest and 7.5 nm southwest of Quang Khe, indicate that these facilities were major components in the logistics network utilized during the truce periods. The strategic location of these facilities between Routes 137 and 1A permits the redistribution of supplies to both Laos and the DMZ area via these respective routes (see accompanying map). This is probably their normal function when supplies are moved south from the railhead of the serviceable Vinh/Doag Hoi Fail Line (17-49N 106-10E) along the Nguon May and Song Troc rivers.

Two significant facts suggest that these facilities were directly involved in the transshipping activity at Quang Khe during the truce periods and that the supplies observed stockpiled on ██████████ were intended for Laos rather than the DMZ area. First, the 14 large sampans located at the northern Quang Khe transshipment point on ██████████ (Figure 15) were unlike any craft ever observed at the southern transshipment points. Second, an extremely large amount of supplies was observed stockpiled away from the river bank at the 2 facilities on the Song Troc later in the month (Figures 17 and 18). It seems reasonable to assume that at least most of these supplies which crossed the river at Quang Khe were intended for further movement south along Route 1A; while any supplies which were carried southwest along the Song Troc would be transhipped for further movement along Route 137.

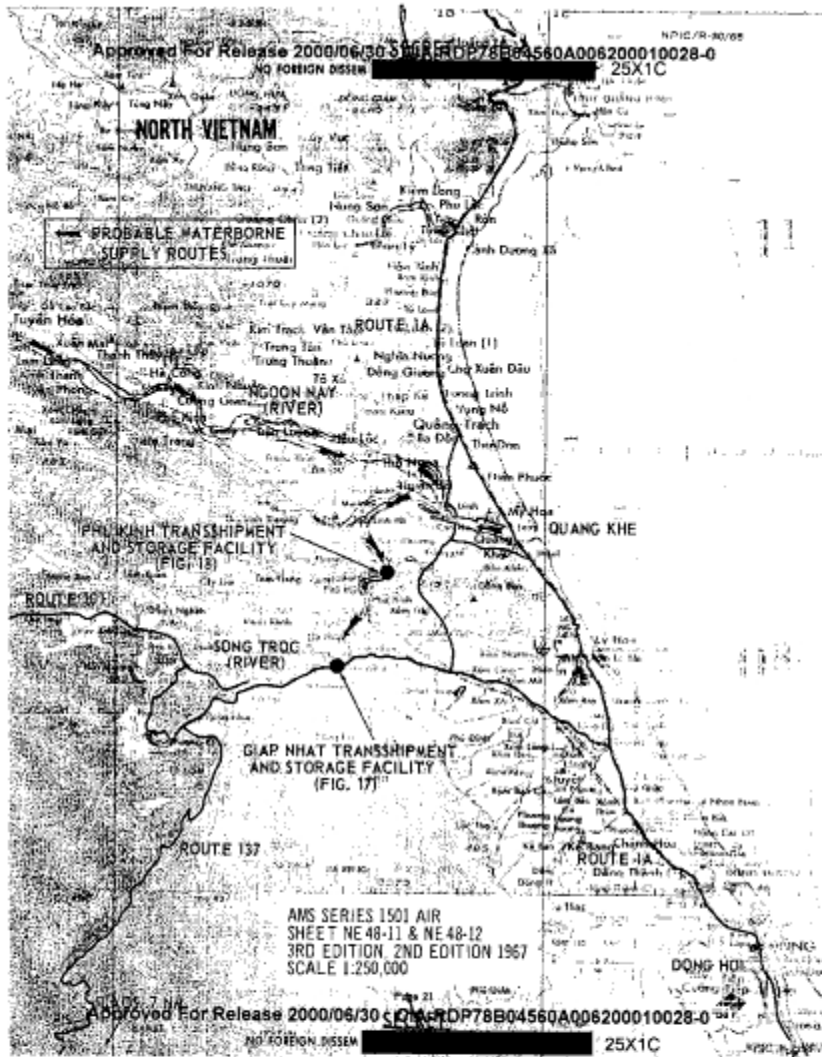
25X1D
25X1D

A partially-submerged sampan appears to have been utilized as an offshore wharf at the Giap Nhat Transshipment Point (Figure 17). Although some residue of supplies remains scattered at the river bank and approximately 70 personnel are observed in the area, the movement to more permanent stockpiles appears nearly complete on the ██████████. In addition to those supplies stored in 2 buildings without roofs, 5 of the 8 stacks of supplies have been covered.

25X1D

By the ██████████ supplies had been stockpiled in 16 separate stacks at the Fou Kinn Transshipment Point (Figure 18), and the area appeared void of activity. This was the first identification of this facility, and it is interesting to note that the access roads have been camouflaged with displaced vegetation.





25X1D



25X1D

FIGURE 17. GIAP NHAY TRANSHIPMENT POINT, SONG TRUC (RIVER), NORTH VIETNAM (17-37N 106-22E)

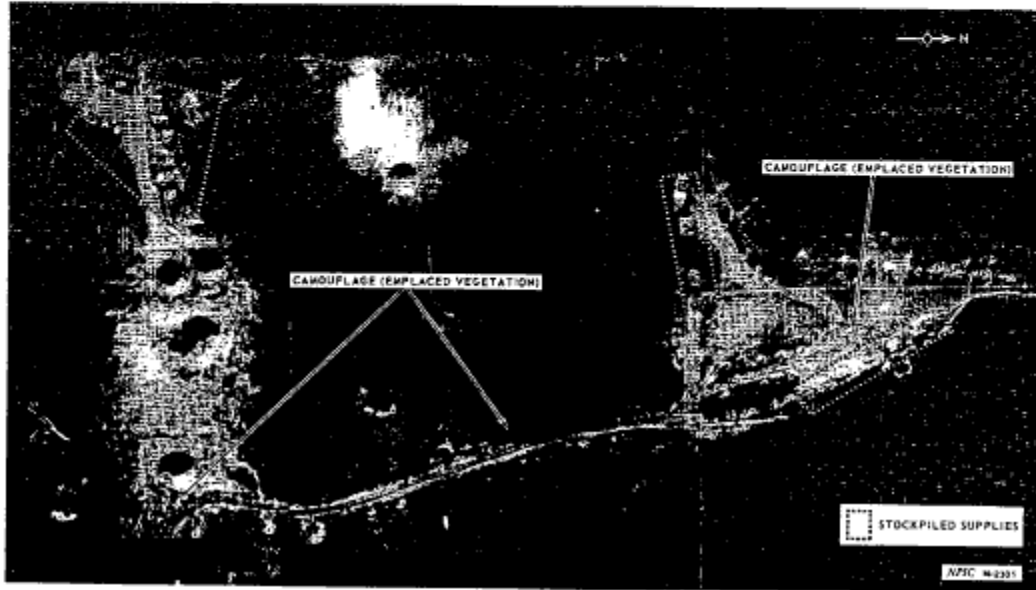
Page 22



NO FOREIGN DISSEM **SECRET** 25X1C

NPIC/R-80/88

25X1D



25X1D

FIGURE 15. PHU KINH TRANSHIPMENT POINT, SONG TROC (RIVER), NORTH VIETNAM (17-40N 106-24E)

Page 23

NO FOREIGN DISSEM **SECRET** 25X1C



~~SECRET~~

MPIC/R/30/88

NO FOREIGN DISSEM

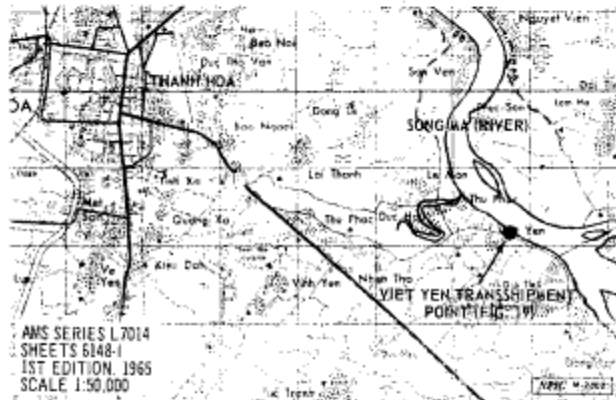
25X1C

Viet Yen Transshipment Point

The only transshipment operation identified in the areas of photographic coverage north of Quang Khe during the truce periods was located near Viet Yen, 3 km east-southeast of Thanh Hoa. Six probably motorized sampans, approximately 40 ft in length, were moored here on [REDACTED] (Figure 19). Eighteen canvas-covered stacks of supplies were located on the adjacent river bank, and 5 cargo trucks were in the immediate vicinity. Additional river craft were observed in the area, as well as in the normal concentrations throughout the Panhandle (approximately 950 sampans/junks were counted on [REDACTED]). However, it is difficult, if not impossible, to associate these with any special logistic effort.

25X1D

25X1D



Page 24

~~SECRET~~

NO FOREIGN DISSEM

25X1C



25X1D

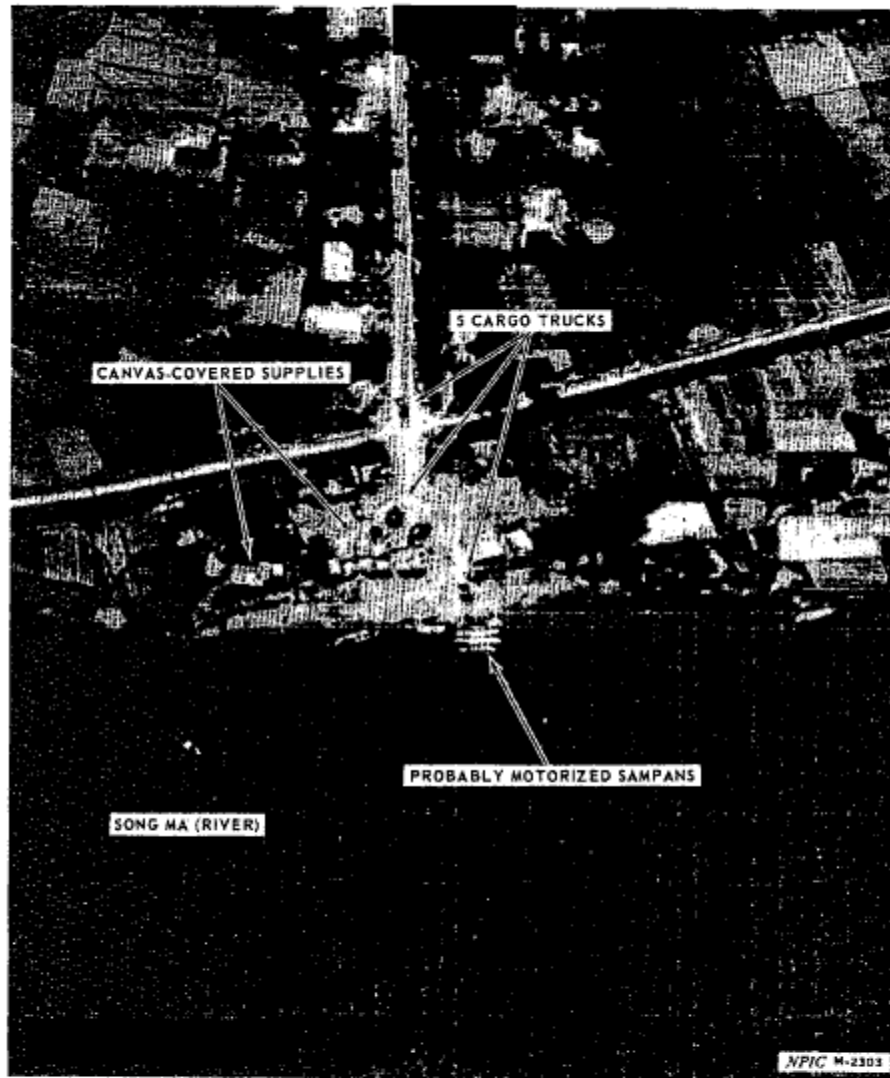
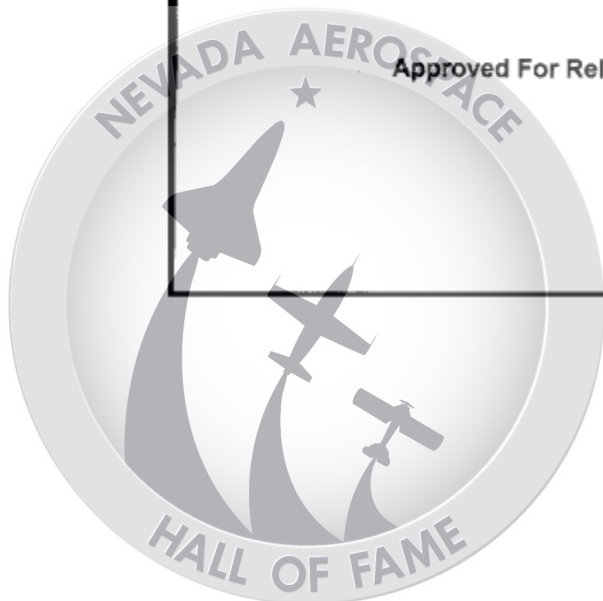


FIGURE 19. TRANSHIPMENT POINT, VIET YEN, NORTH VIETNAM (19-47N 105-49E)



Yen Phu Area Logistics Activity

Two major supply points were identified within 1 nm of Yen Phu during the Christmas and New Year Truce Periods and their location, precisely halfway between Thanh Hoa and Vinh, lends some credence to the reported shuttle system employed for the movement of supplies. In addition, the Route 1A alternate river crossings at Yen Phu provide one of the better comparisons of logistic support activity during truce and non-truce periods.

25X1D Sixteen large stacks of supplies were dispersed around a loop road within the village of Thien Ki, immediately north of Yen Phu, on [REDACTED] 25X1D (Figure 20). Although most of the supplies were covered, many apparent rice sacks were visible. Some of the supplies had been placed in partially dismantled huts, suggesting that other apparently native dwellings in the area were also being used for storage. Seven trucks were probably awaiting cargo at that time. By [REDACTED] 6 of 25X1D the stacks had been either removed or partially removed, and additional supplies had been stockpiled in a previously unused area.

25X1D Cargo trucks were also being loaded at the supply point immediately south of Yen Phu on [REDACTED] (Figure 21). In addition to the probable storage building adjacent to the trucks, 15 canvas-covered and open stacks of supplies (ranging from approximately 10 x 40 x 15 ft to 30 x 100 x 15 ft) were dispersed under a sparse tree canopy. At least 3 of 25X1D these stacks had been partially removed by [REDACTED]

25X1D Figure 22 depicts the normal daylight status of 2 Route 1A river crossings at Yen Phu. (A third alternate crossing remained unserviceable throughout the 2 truce periods and is not depicted.) Temporary pontoon bridges were positioned at these crossings on [REDACTED] and then 25X1D removed before the [REDACTED] (Figure 23). Only 1 of the bridges was repositioned for the New Year Truce and the resulting bottleneck was evident at the bridge (Figure 24) as well as 300 meters south (Figure 4).



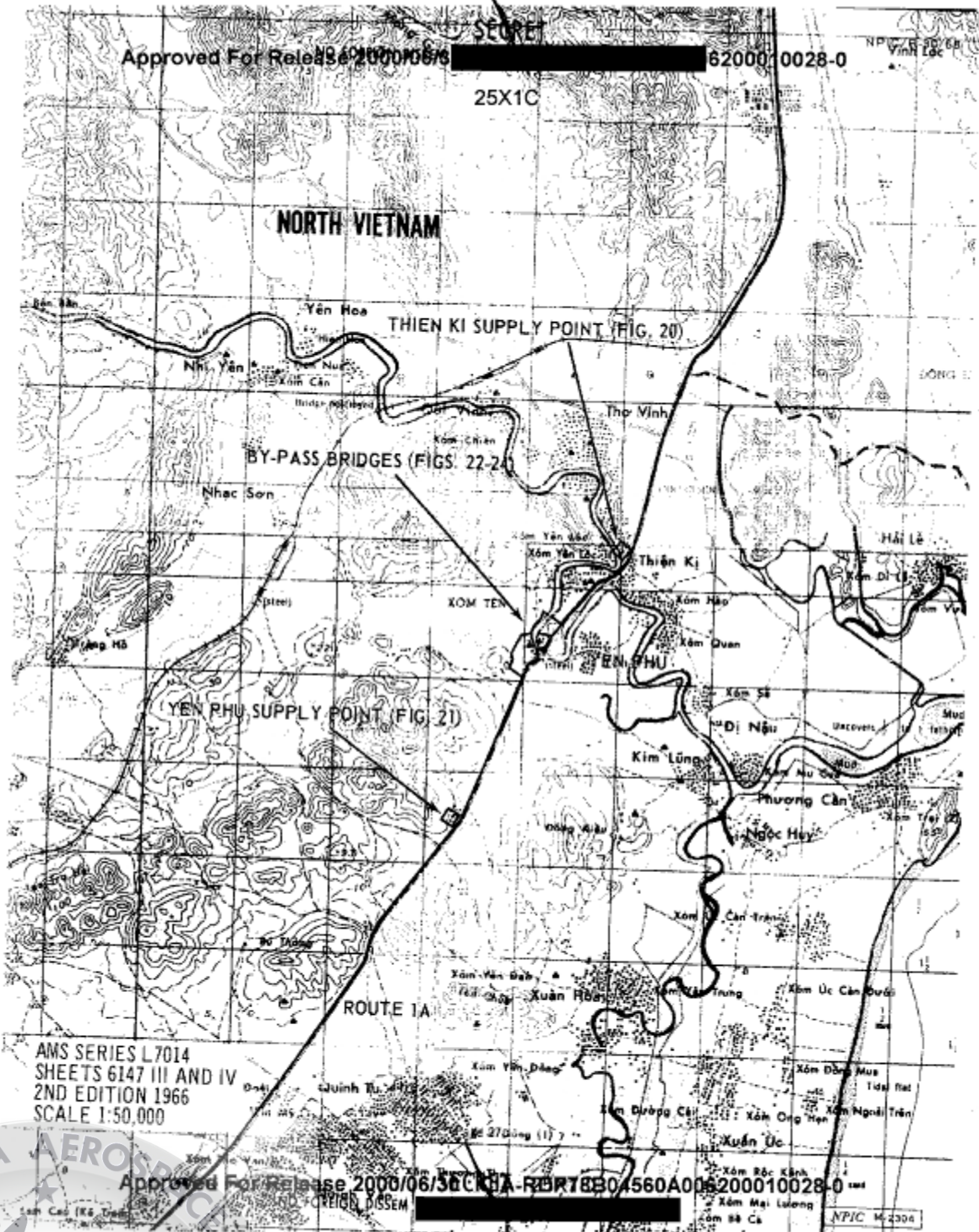
Approved For Release 2000/06/06 : CIA-RDP78B04560A006200010028-0

SECRET

62000 0028-0

25X1C

NORTH VIETNAM



AMS SERIES L7014
SHEETS 6147 III AND IV
2ND EDITION 1966
SCALE 1:50,000

Approved For Release 2000/06/06 : CIA-RDP78B04560A006200010028-0



NO FOREIGN DISSEM

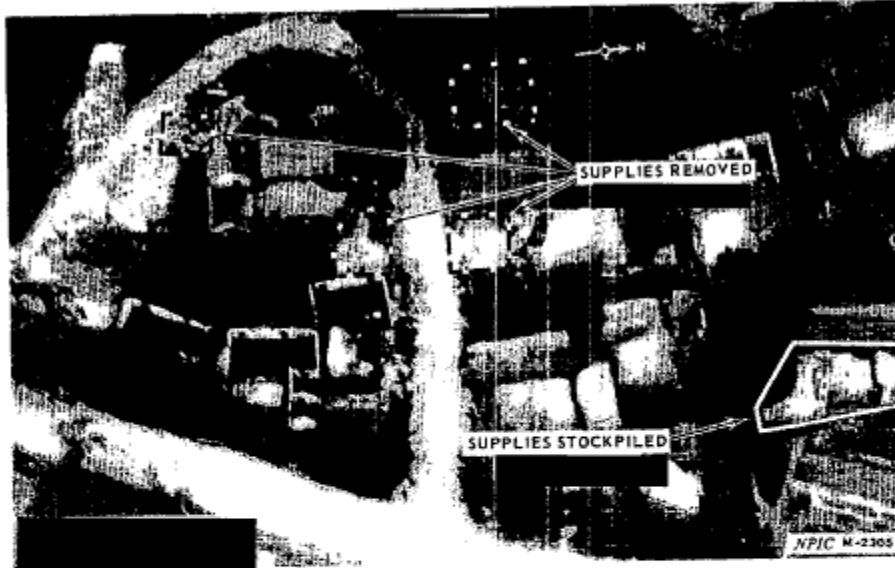
25X1C

25X1D



25X1D

25X1D



25X1D

25X1D

FIGURE 20. THIEN KI SUPPLY POINT, ROUTE 1A, NORTH VIETNAM (19-15N 105-42E)

Page 28

NO FOREIGN DISSEM

25X1C



25X1D



Approved For Release: 2000/06/30 : CIA-RDP78B04500A000200010028-0

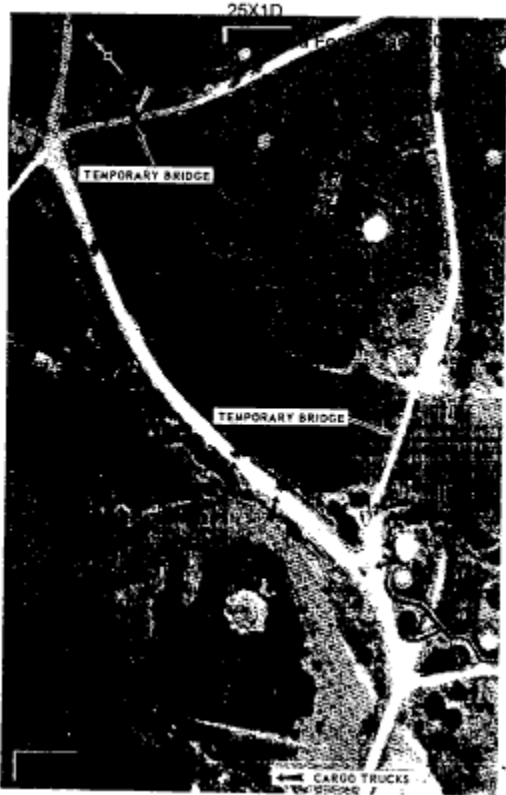


25X1D
Approved For Release 2000/06/30 : CIA-RDP78B04560A006200010028-0



FIGURE 22. ALTERNATE RIVER CROSSINGS, ROUTE 1A, NORTH VIETNAM (19-14N 105-42E)
Approved For Release 2000/06/30 : CIA-RDP78B04560A006200010028-0

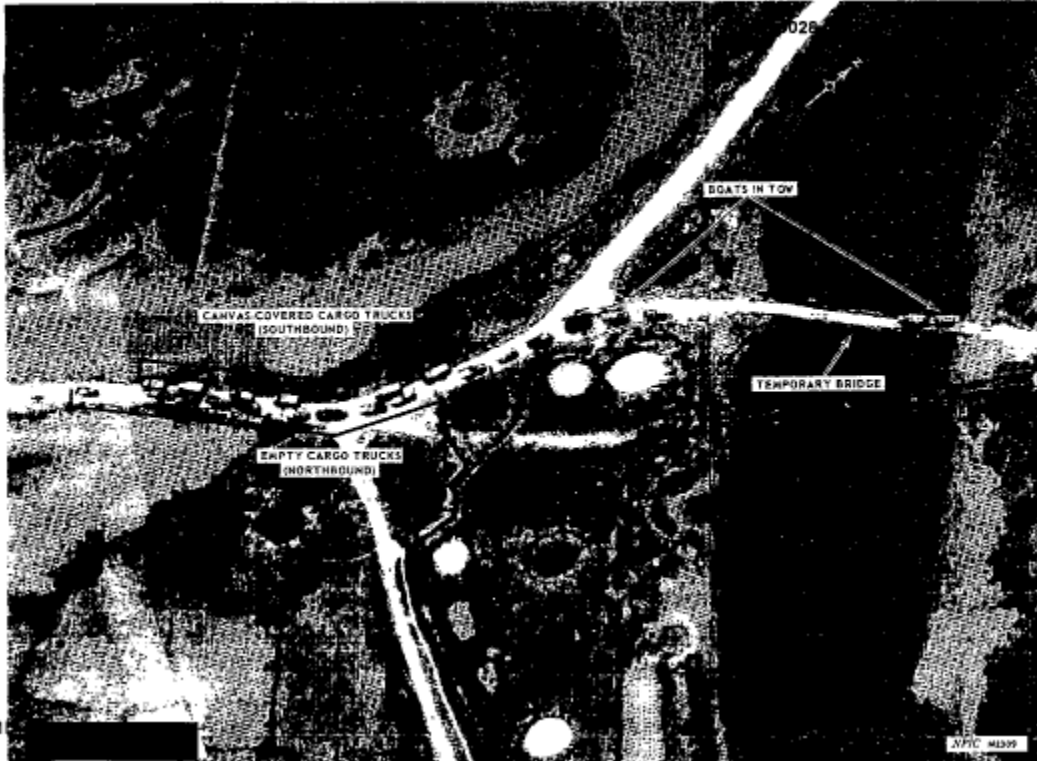




Approved For Release 2009/08/30 : CIA-RDP78B04560A0062000300028-0



25X1D



Approved For Release: 2000/06/30 : CIA-RDP78B04660R000200010028-0



Although not approaching the spectacular volume of vehicular activity, the observed daylight usage of the Ha Noi/Vinh Rail Line during the Christmas and New Year Truce Periods was both substantial and atypical. Large numbers of stationary rolling stock are frequently located along the line, [REDACTED]

25X1D

25X1D

25X1D

On [REDACTED] 3 short supply trains were observed moving on the rail line between Thanh Hoa and Vinh (Figures 25 and 26). As suggested by these photographs, ferries are utilized exclusively on this segment of the line, probably due to the inadequacy of the numerous small bridges to support the much heavier locomotives.

25X1D

The longest train observed moving during the 2 truce periods was headed south on [REDACTED] between Minh Binh and Thanh Hoa. This train included 11 camouflaged boxcars, 3 unladen-covered flatcars, and 2 covered gondolas (Figure 27). Another supply train, located 1.5 mi south of Minh Binh, was partially imaged on the same day and included 3 open gondolas filled with sacks of material, 1 boxcar, and 4 small PGL cars camouflaged as boxcars. Although this train was probably stationary, it is most unusual to photograph classified trains during the day.

Additional activity in the Minh Binh area during the New Year Truce included rail transshipping (Figure 28) and the positioning of 3 rail ferries to form a bridge across the Song Day (river). This was the first observation of a temporary rail bridge at this site, and it was not utilized again during Tet (Figure 30).

No trains, either moving or stationary, were observed during the Tet Truce Period. However, a northbound train was observed between Thanh Hoa and Minh Binh on [REDACTED] (Figure 29), and a ferry-pulled train was struck 30 mi south of Thanh Hoa on [REDACTED]

25X1D

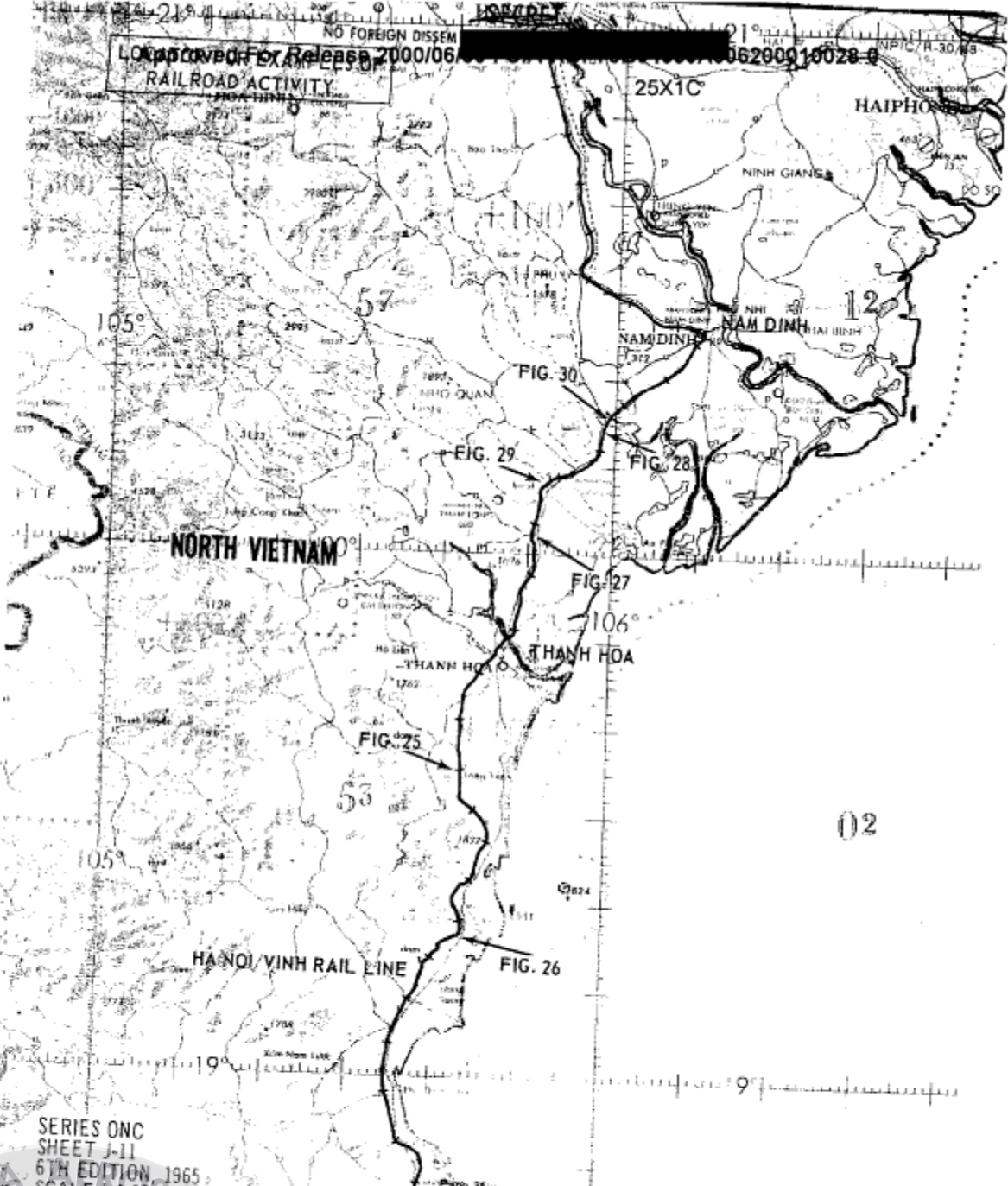
25X1D

25X1D

but together with other isolated examples referenced in this report, it suggests either a sense of urgency on the part of the North Vietnamese or a disdain for Allied bombing operations.



NO FOREIGN DISSEM
Approved For Release 2000/06/06 : CIA-RDP78B04560A006200010028-0
RAILROAD ACTIVITY

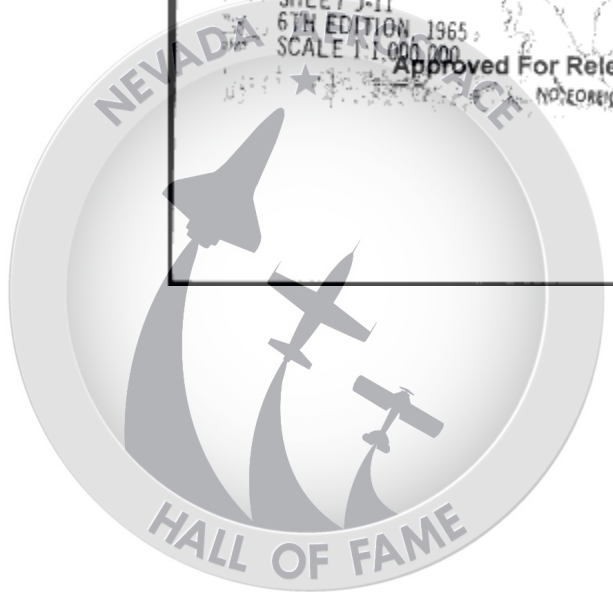


SERIES ONC
SHEET J-11
6TH EDITION 1965
SCALE 1:1,000,000

Approved For Release 2000/06/06 : CIA-RDP78B04560A006200010028-0
NO FOREIGN DISSEM
25X1C

02

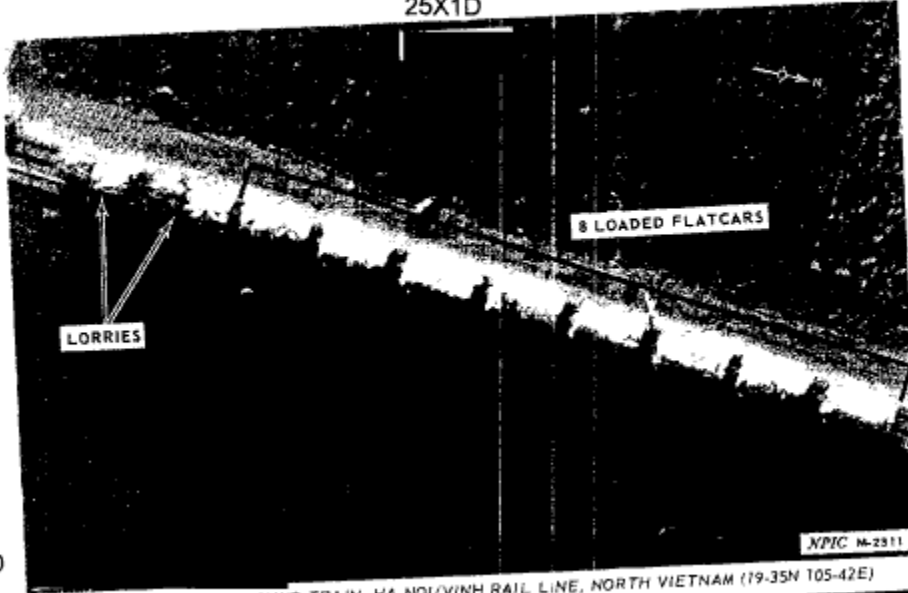
NPIC M-2510



NO FOREIGN DISSEM

25X1C

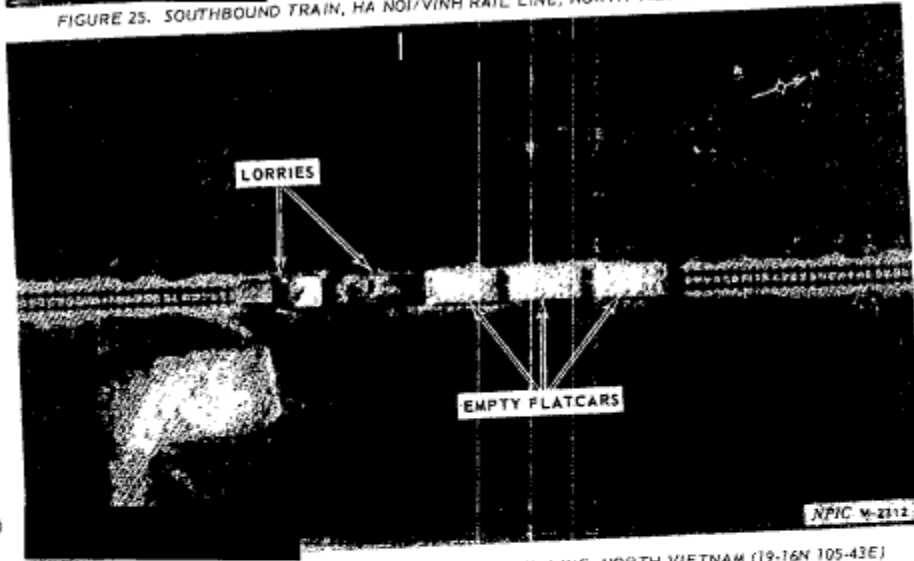
25X1D



25X1D

FIGURE 25. SOUTHBOUND TRAIN, HA NOI/VINH RAIL LINE, NORTH VIETNAM (19-35N 105-42E)

25X1D



25X1D

FIGURE 26. SOUTHBOUND TRAIN, HA NOI/VINH RAIL LINE, NORTH VIETNAM (19-16N 105-43E)

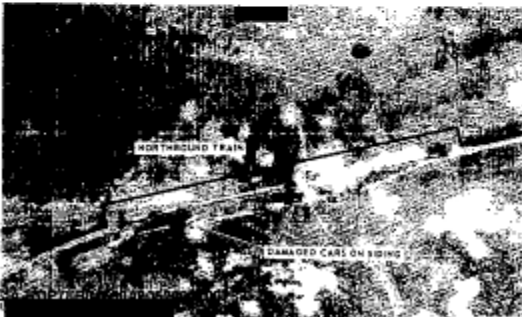
NO FOREIGN DISSEM

25X1C

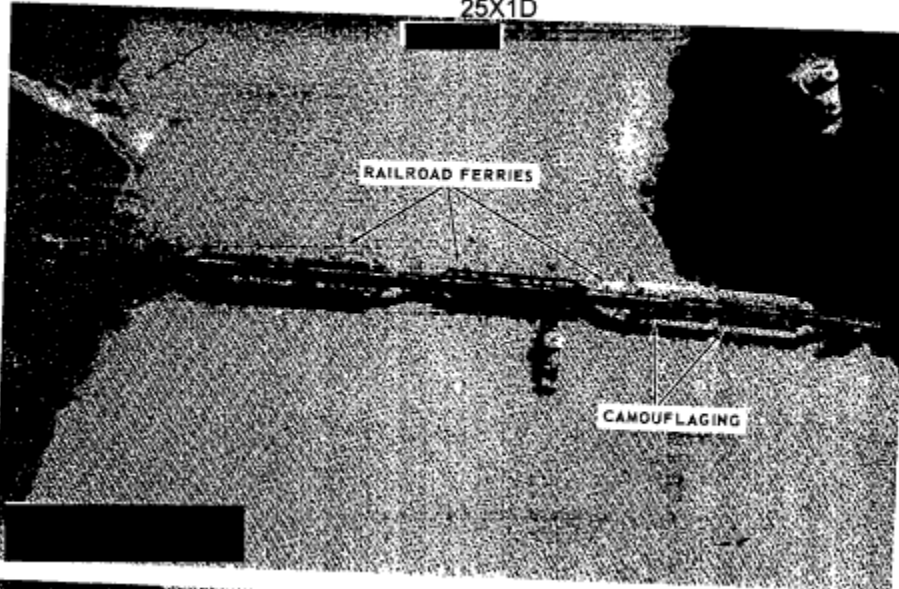




FIGURE 27. SOUTHBOUND SUPPLY TRAIN, HA NOI-YIMP RAIL LINE, NORTH VIETNAM (35 20N 104.37E)



25X1D



25X1D

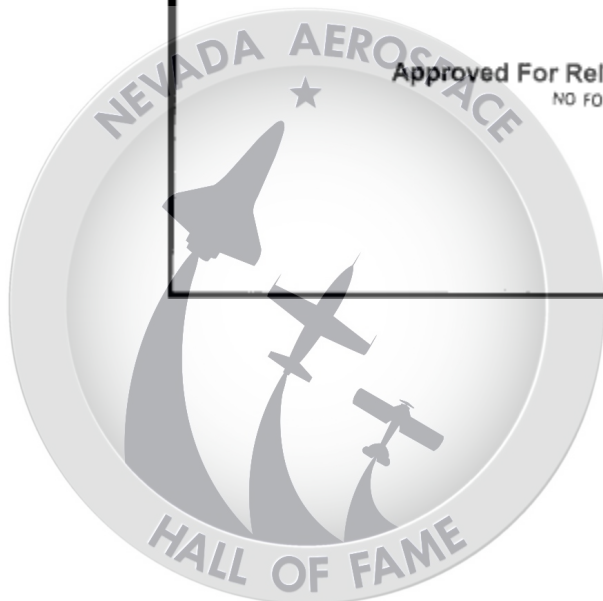
25X1D



25X1D

FIGURE 30. RAILROAD FERRY CROSSING AND TEMPORARY BRIDGE, NINH BINH, NORTH VIETNAM
(20-15N 105-59E)

Page 39



~~SECRET~~

NPIC/R-30/68

25X1C

APPENDIX

Page #1

~~SECRET~~

25X1C



NO FOREIGN DISSEM [REDACTED]

VEHICLE SIGHTINGS AND HEADINGS

25X1D	Route	Latitude (In Degrees)	Heading North	Heading South	Heading Undetermined*
[REDACTED]	1A	18 - 19	0	0	40
	1A	19 - 20	0	0	12
	12	20 - 21	0	0	21
	15	18 - 19	0	0	19
	108	18 - 19	0	0	30
	211	20 - 21	0	0	8
	Other		0	0	27
	Total		0	0	157
Christmas Truce	1A	17 - 18	69	109	7
	1A	18 - 19	3	46	0
	1A	19 - 20	244	205	86
	101	17 - 18	2	1	0
	104	17 - 18	4	2	0
	106	17 - 18	0	2	0
	107	17 - 18	1	4	0
	108	17 - 18	4	50	0
	110	17 - 18	3	2	2
	137	17 - 18	5	1	2
	194	19 - 20	0	6	0
	Total		337	396	97
New Year Truce	1A	17 - 18	44	63	56
	1A	18 - 19	0	0	0
	1A	19 - 20	341	277	59
	1A	20 - 21	18	26	0
	10	20 - 21	10	12	0
	107	19 - 20	0	4	0
	108	19 - 20	31	9	0
	701	19 - 20	11	9	0
	704	19 - 20	1	1	0
	Total		456	403	115

NO FOREIGN DISSEM [REDACTED]



25X1C

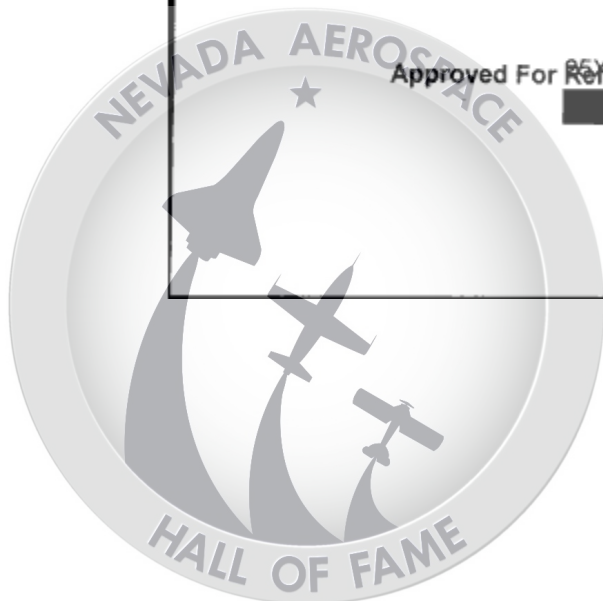
~~SECRET~~

[REDACTED]

	Route	Latitude (In Degrees)	Heading North	Heading South	Heading Undetermined*
Test Truce	1A	17 - 18	0	1	0
	1A	18 - 19	2	7	83
	1A	19 - 20	5	3	5
	1A	20 - 21	0	10	0
	7	18 - 19	0	0	4
	10	20 - 21	5	10	16
	15	17 - 18	0	1	0
	15	18 - 19	0	2	0
	21	20 - 21	0	0	1
	92	20 - 21	0	0	9
	101	17 - 18	0	1	3
	118	19 - 20	0	0	10
	151	18 - 19	0	0	3
	210	20 - 21	2	0	4
	706	19 - 20	0	0	3
	Total			14	35

*Sightings on east-west routes are included in this column.

[REDACTED]



NPIC BRIEFING BOARD REFERENCES

1966 Christmas Truce Period

L-2528 Truck Convoy, Route 701, NVN

1967 TET Truce Period

L-2725 Trucks, Route 1A, NVN
L-2727 Transshipment Operation, Quang Khe, NVN
L-2728 Truck Convoy, Mu Gia Pass Area, NVN
L-2729 Truck Convoys, Mu Gia Pass Area, NVN
L-2754 Truck Convoys, Mu Gia Pass Area, NVN

1967 Christmas Truce Period

L-4721 Transshipment Activity (Morning), Quang Khe, NVN
L-4722 Supply Point, Thien Ki, NVN
L-4723 Transshipment Activity (Afternoon), Quang Khe, NVN
L-4724 By-Pass Bridges, Yen Phu, NVN
L-4725 River Crossing Activity, Non, NVN
L-4726 Rail Activity, Thanh Hoa Area, NVN
L-4727 Christmas Truce Activity
L-4728 Supply Point, Yen Phu, NVN
L-4729 Transshipment Point, Viet Yen, NVN
L-4733 Vehicle Activity, NVN

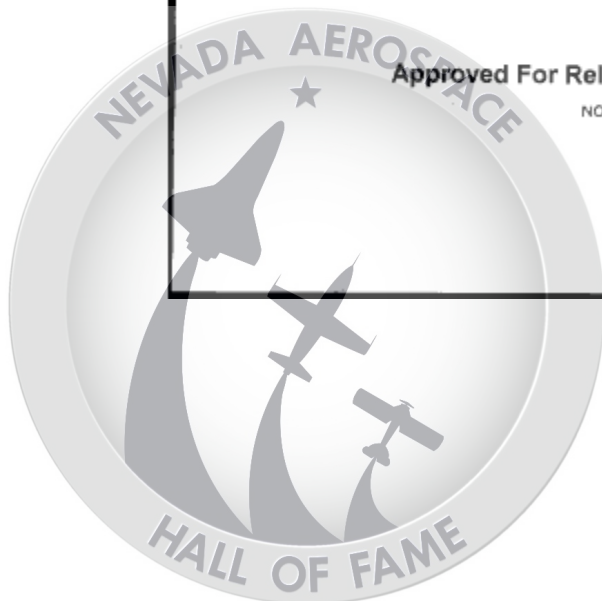
1968 New Year Truce Period

L-4740 Transshipment Activity, Quang Khe, NVN
L-4746 Waterborne Activity, Thanh Hoa Area, NVN
L-4747 Vehicle Activity, New Years Truce, NVN
L-4749 Rail Activity, Minh Binh-Thanh Hoa Area, NVN
L-4750 New Years Truce Activity, NVN
L-4751 By-Pass Bridge, Yen Phu, NVN
L-4753 Supply Points, Yen Phu/Thien Ki, NVN

1968 Pre-Tet Period

L-4819 Rail Activity, Minh Binh-Thanh Hoa Area, NVN
L-4820 Road Repair, Route 15, NVN
L-4828 Transshipment Point, Giap Nhat, NVN
L-4829 Transshipment Point, Song Vinh/Huong Mai, NVN

Page 44

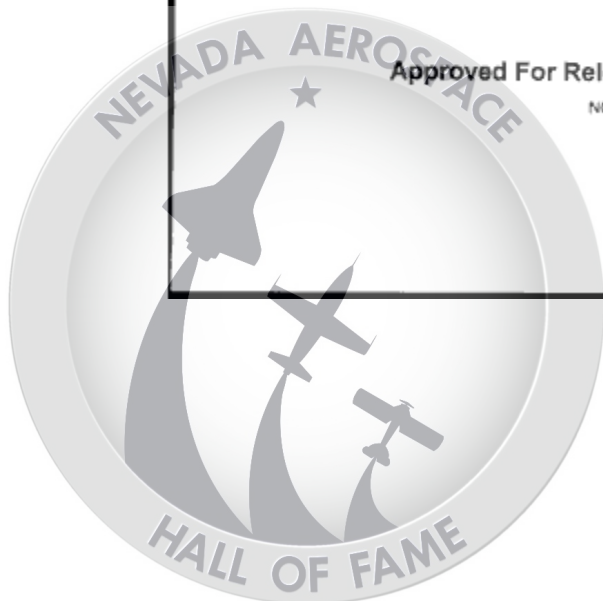
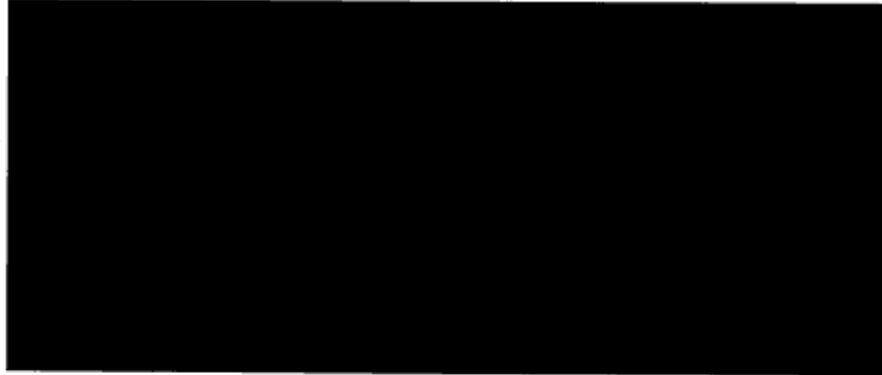


1968 Tet Truce Period

L-4812 Transshipment Points, Quang Khe, NVN
L-4817 Vehicles in Village Sanctuaries, NVN
L-4826 Rail Activity, Ninh Binh, NVN
L-4827 Vehicle Activity NVN

MISSION REFERENCES

25X1D



Approved For Release 2000/06/30 : CIA-RDP78B04560A006200010028-0
NO FOREIGN DISSEM ~~SECRET~~ 25X1C

Approved For Release 2000/06/30 : CIA-RDP78B04560A006200010028-0
NO FOREIGN DISSEM ~~SECRET~~ 25X1C



Title:	(EST PUB DATE) SOUTHEAST ASIS ACTIVITY REPORT - NORTH VIETNAM LOGISTICS ACTIVIT
Abstract:	
Pages:	0047
Pub Date:	2/1/1968
Release Date:	7/24/2001
Keywords:	OXCART SR-71 BLACKBIRD BLACK SHIELD A-12
Case Number:	F-2000-01388
Copyright:	0
Release Decision:	RIFPUB
Classification:	U



187

Approved For Release 2000/06/30 : CIA-RDP78B04560A006200010028-0
~~SECRET~~
NO FOREIGN DISSEM [REDACTED] 25X1C

PHOTOGRAPHIC INTERPRETATION REPORT



SOUTHEAST ASIA
ACTIVITY REPORT

NORTH VIETNAM
LOGISTICS ACTIVITY
1967-68 TRUCE PERIODS

NPIC/R-30/68
FEBRUARY 1968

GROUP 1 EXCLUDED FROM
AUTOMATIC DOWNGRADING
AND DECLASSIFICATION

Approved For Release 2000/06/30 : CIA-RDP78B04560A006200010028-0
~~SECRET~~
NO FOREIGN DISSEM [REDACTED] 25X1C

Approved for Release: JUL 2001



Approved For Release 2000/06/30 : CIA-RDP78B04560A006200010028-0

WARNING

This document contains information affecting the national defense of the United States, within the meaning of Title 18, sections 793 and 794, of the U.S. Code, as amended. Its transmission or revelation of its contents to or receipt by an unauthorized person is prohibited by law.

Approved For Release 2000/06/30 : CIA-RDP78B04560A006200010028-0



RECORD COPY	COPY NO.	PUB. DATE	LOCATION	MASTER	DATE RECEIVED	LOCATION					
Approved For Release 2000/06/30 : CIA-RDP78B04560A006200010028-0											
CUT TO COPIES	DATE	CUT TO COPIES	DATE	STOCK	MINIMUM	MAXIMUM					
25	7-70					10					
CUT TO COPIES	DATE	CUT TO COPIES	DATE	COPIES DESTROYED							
10	7-72										
CUT TO COPIES	DATE	MASTER	DATE								
0	7-74										
DATE			RECEIVED OR ISSUED			NUMBER OF COPIES					
NO.	DAY	YR.	REC'D	ISS'D	BAL	NO.	DAY	YR.	REC'D	ISS'D	BAL
2	29	68			51						51
	10	11									1 50
	12	68									1 49
	7	69									4 45
	8	69									1 44
	1	71									10
	8	73									10 0
25X1C											
Approved For Release 2000/06/30 : CIA-RDP78B04560A006200010028-0											

TITLE NPIC/R-30/68 Feb. 1968. [REDACTED] 505116 X



PREFACE

This report is a summary of selected information on transportation and infiltration activity in southeast Asia as reported by NPIC during the period indicated on the cover. Those lines of communication and associated facilities which support communist insurgency in Laos and South Vietnam are emphasized.

Items are numbered and arranged according to location from north to south. Annotated maps of varying scales have been included to assist the reader in locating the items. Each large-scale map depicts all motorable roads photographically confirmed by NPIC unless otherwise indicated.

Missions, mission dates, frames, and NPIC cable and briefing board references are listed after each item, as appropriate.



INTRODUCTION

25X1D This report summarizes the logistics activity in the Panhandle area of
North Vietnam during the [REDACTED] truce periods. As in the past, the North
25X1D Vietnamese fully exploited the 36-hour U.S. bombing cessations during the
Christmas [REDACTED] and New Year [REDACTED] 25X1D
25X1D [REDACTED] Truce Periods and, to a lesser extent,
the Tet Truce Period [REDACTED] 25X1D

As indicated by the accompanying map, there were significant photogra-
phic gaps during each of the periods. However, the coverage was complete
enough to permit an assessment of the activity and a comparison of the
periods. Reference is also occasionally made to [REDACTED] of 25X1D
25X1D [REDACTED] It is felt that this mission reflected a normal daylight
activity level for this area of North Vietnam.

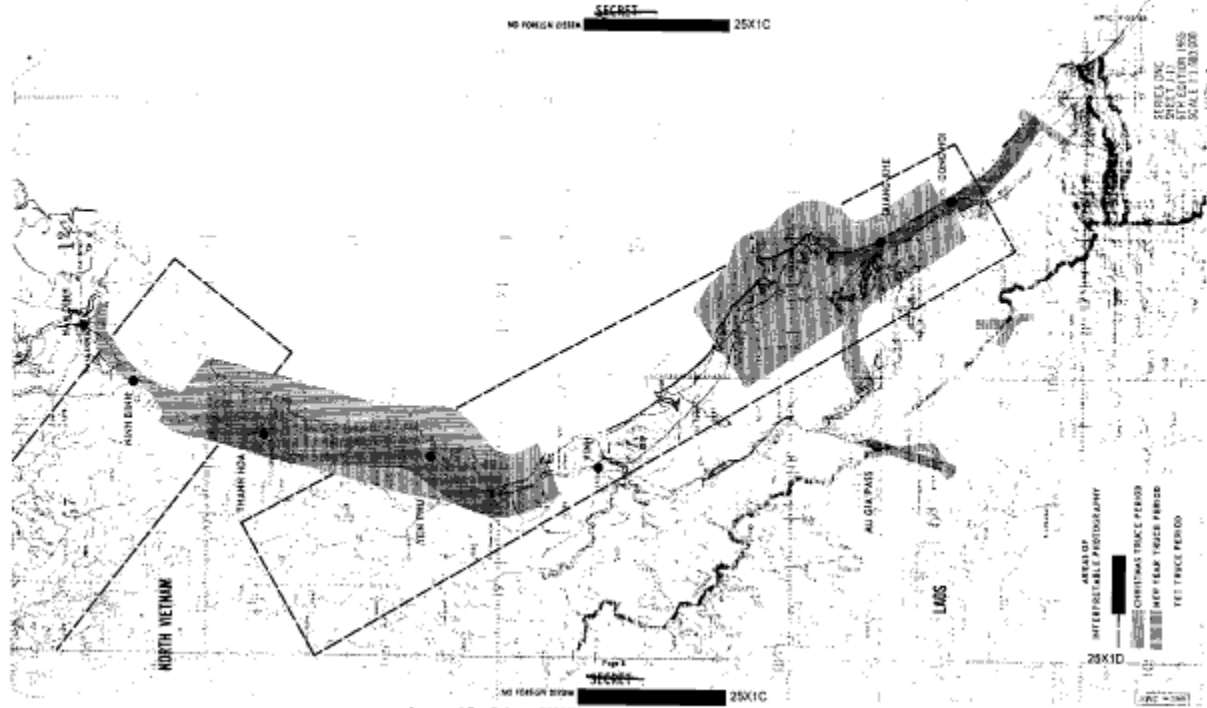
To facilitate a comparison of the logistics activity, the report has
been divided into the following sections: Vehicular Activity, pp 4-12;
Quang Khe Transshipment Points, pp 13-19; Song Troc (River) Transshipment
Points, pp 20-23; Viet Yen Transshipment Point, pp 24-25; Yen Phu Area
Logistics Activity, pp 26-33; and Railroad Activity, pp 34-39. Except for
those craft observed at transshipment points, no waterborne activity could
be associated with the southern movement of supplies during these periods.

25X1D Tables of comparative vehicular activity during each of the truce
periods have been included in the appendix. These totals are not intended
as precise vehicle counts and should be used only for comparison purposes.
While it is doubtful that any convoys or major concentrations of vehicles
were successfully concealed on [REDACTED] individual vehicles are extremely
difficult to detect on Black Shield photography in areas of dense vegeta-
tion or along tree-lined routes. It is also logical to assume that some
duplicate "sightings" occurred during the truce periods, although the total
effect was minimized by the small number of missions and amount of overlap.

Page 2



SECRET
NO FOREIGN DISSEM 25X1C



Page 1
NO FOREIGN DISSEM 25X1C



~~SECRET~~

NO FOREIGN DISSEM

25X1C

Vehicle Activity

25X1D

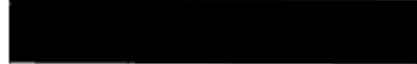
Identifiable photographic coverage during the Christmas and New Year Truce Periods was generally limited to the coastal routes north of Hueh, and, directly north LA. Although there were significant photographic gaps -- (partly attributable to poor weather conditions -- in the areas of the depressed inland routes carrying the logistics out in Laos (Routes 5, 101, 110, and 127) and along a 400-mile coastal segment in the vicinity of Vinh, there were 1035 and 978 vehicle sightings during these periods, respectively. In contrast, only 157 vehicles were identified in a much larger area of [redacted] (see map, page 3).

As suggested by the examples of vehicular activity included herein (Figures 1-6, 10), over half of the vehicles sighted during both periods were in transit on Route 1A between 19-02E and 25-02E. Contrary to the traffic pattern indicated by these examples, vehicular activity generally consisted of individual or scattered groups of trucks rather than convoys. Observations were frequently observed at river crossings, however, where such the obvious precaution was necessary to maintain a smooth flow of the high-volume traffic.

The majority of the vehicles sighted were conventional 3 1/2-ton cargo trucks, although numerous sub-compact trucks were also observed. Most of the cargo beds were canvas-covered, especially on reinforced handles. Vehicle cargo appeared to be tanks of material in the form of [redacted] [redacted] [redacted]. Many of the trucks also carried either VCL drums or a single large VCL storage tank, the latter probably serving the [redacted] [redacted].

Except for the canvas-covered beds, there was little or no attempt to camouflage the vehicles or their movement. Conventional trucks were rarely camouflaged and the wooden frames which are frequently erected over the cab and hood were without the customary [redacted].

The vehicular activity observed during the Truce Period by sharply contrasted with that of the Christmas and New Year Truce. There were only 100 vehicles sighted during this period and most of them were parked in cities and villages. The drastic reduction in sightings can be [redacted] [redacted] [redacted].



25X1D

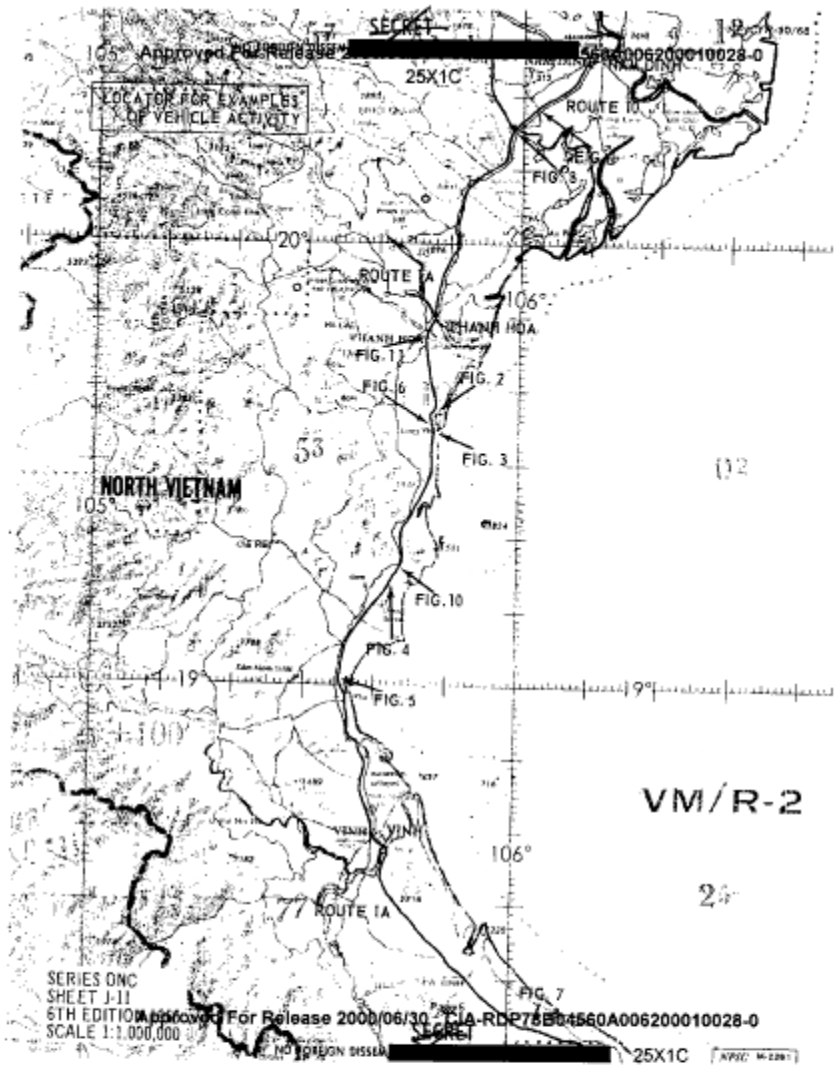
Page 1

~~SECRET~~

NO FOREIGN DISSEM

25X1C





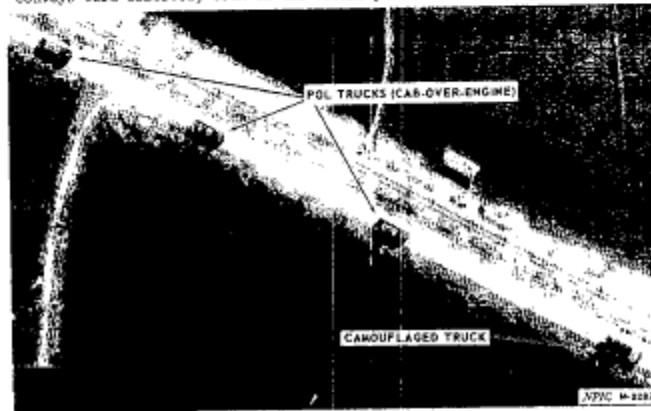
As bombing operations continued south of Vinh, a normal daylight vehicular pattern was maintained there during the Tet Period. Only 11 moving vehicles were sighted south of Vinh as compared to approximately 100 and 165 during the Christmas and New Year Periods, respectively. (It should also be noted that a greater area was covered by interpretable

25X1D [REDACTED] 25X1D

Only 1 vehicle was observed on Route 15 north of the Mu Gia Pass during this year's Tet Period as compared to approximately 200 during the 2-day Tet Bruce [REDACTED] (NPIC Briefing Board L-2754). However, in spite of the potential air strikes, road repair/maintenance was underway during daylight hours both prior to and during Tet (Figure 9). This perhaps reflected an urgency to keep open the most important logistics route into Laos.

As indicated above, there was relatively little vehicular movement observed even north of Vinh. Isolated instances of abnormal preparations for vehicular movement were noted, i.e., the positioning of a temporary bridge at Minh Binh during daylight hours (Figure 8); but only 2 small convoys were observed, both in the vicinity of Thanh Hoa (Figure 11).

25X1D



25X1D

FIGURE 1. VEHICLE ACTIVITY, ROUTE 10, NORTH VIETNAM (20-19N 106-01E)

Page 6



NO FOREIGN DISSEM ~~SECRET~~ 25X1C

REF ID: A61618

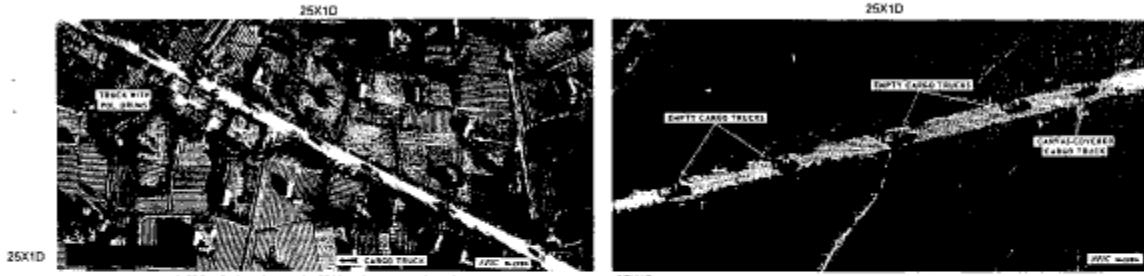


FIGURE 2. VEHICLE ACTIVITY, ROUTE 1A, NORTH VIETNAM (17-10N 106-40E)

FIGURE 3. VEHICLE ACTIVITY, ROUTE 1A, NORTH VIETNAM (17-10N 106-42E)



FIGURE 4. VEHICLE ACTIVITY, ROUTE 1A, NORTH VIETNAM (17-10N 106-43E)

Page 1

NO FOREIGN DISSEM ~~SECRET~~ 25X1C



NO FOREIGN DISSEM **SECRET** 25X1C

25X1D

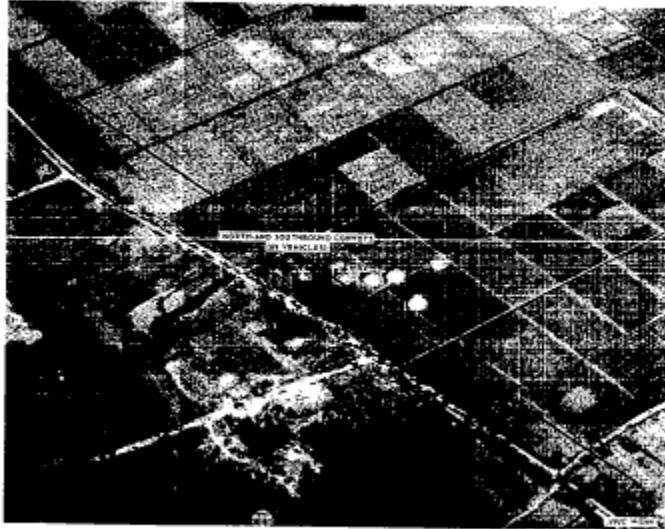


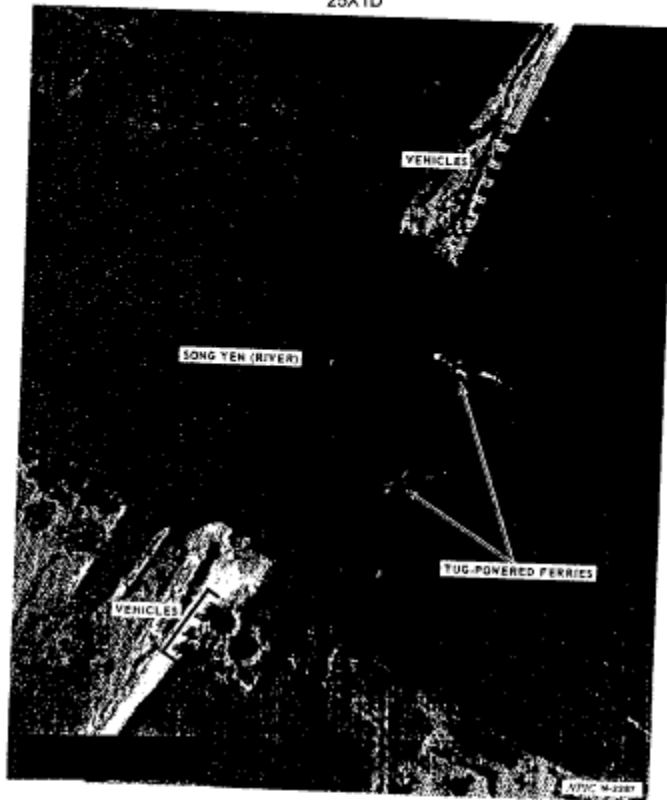
FIGURE 8. VEHICLE ACTIVITY, ROUTE 1A, NORTH WYANNA (FROM ISLIDE)

Page 4

NO FOREIGN DISSEM **SECRET** 25X1C



25X1D



25X1D

FIGURE 6. RIVER CROSSING, PHUNG CAT, NORTH VIETNAM (19-35N 105-47E)

Page 9



25X1D



25X1D

FIGURE 7. PARKED VEHICLES, HA TINH AREA, NORTH VIETNAM (18-12N 106-08E)

Page 12



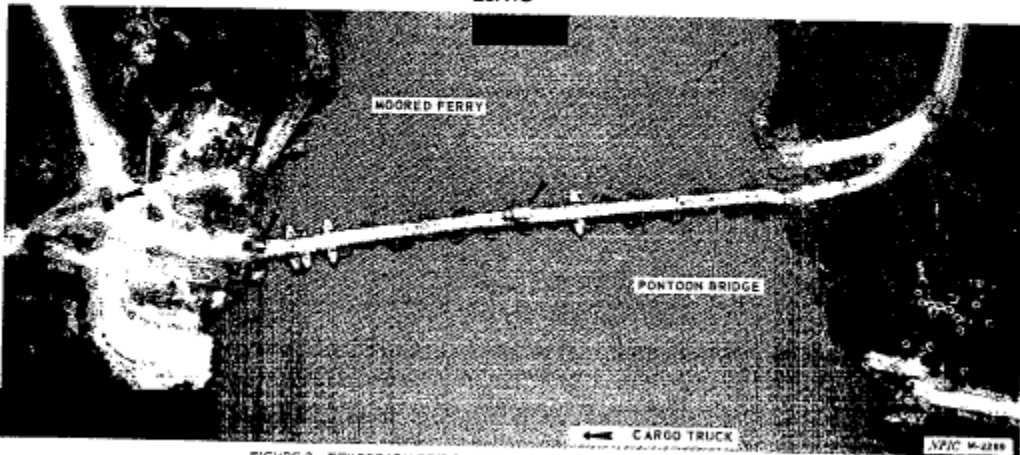
SECRET

NO FOREIGN DISSEM

25X1C

NPIC/R-30/68

25X1D

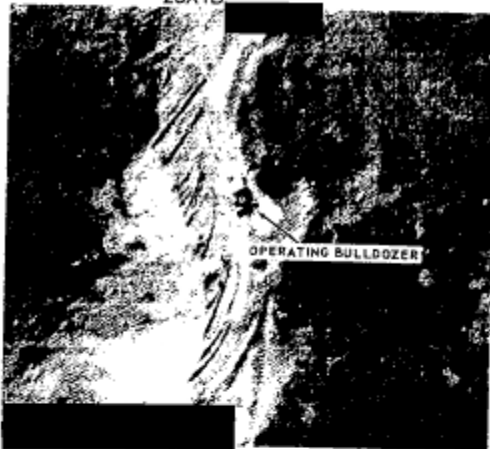


25X1D

25X1D

FIGURE 8. TEMPORARY BRIDGE, NINH BINH, NORTH VIETNAM (20-15N 105-59E)

25X1D



25X1D

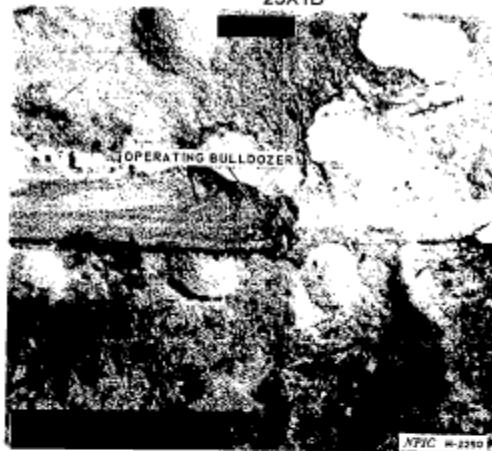


FIGURE 9. ROAD REPAIR/IMPROVEMENT, ROUTE 15, NORTH VIETNAM

25X1D

Page 11

SECRET

NO FOREIGN DISSEM

25X1C



SECRET

NO FOREIGN DISSEM

25X1C

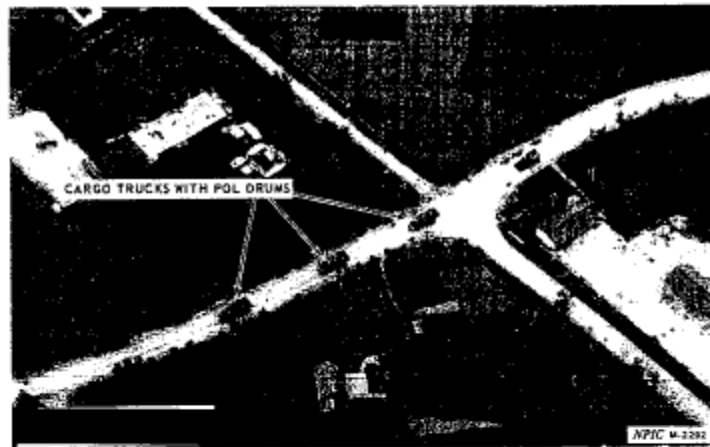
25X1D



25X1D

FIGURE 10. VEHICLE ACTIVITY, ROUTE 1A, NORTH VIETNAM (19-16N 105-43E)

25X1D



25X1D

FIGURE 11. VEHICLE ACTIVITY, THANH HOA AREA, NORTH VIETNAM (19-48N 105-05E)

Page 12

SECRET

NO FOREIGN DISSEM



Quang Khe Transshipment Points

The Quang Khe Transshipment Points once again provided the most vivid example of North Vietnamese exploitation of the U.S. bombing cessation during the Christmas and New Year Truce Periods. For the second year in a row, the north and south banks of the Song Giang (river) in the vicinity of the destroyed Quang Khe naval facilities erupted in a frenzy of transshipping activity. Unlike the Tet Truce Period when major logistics craft (including the first sightings of the SL-1 in North Vietnam) were involved, this year's activity was generally limited to the ferrying of supplies across the Song Giang by small and medium-sized sampans. However, there was no appreciable diminution in the overall levels of activity.

25X1D

Three transshipment points, 1 on the north bank and 2 on the south, were utilized during the 2 truce periods (see accompanying map). Extensive preparation was required for the use of Point No. 2 since the causeway leading to Route 1A had been heavily damaged. Figure 12 depicts the progression of activity: 1) the damaged causeway and inactive transshipment point on [redacted] 2) the off-loading and stacking of supplies prior to 1200 hours on [redacted] and 3) the column of vehicles waiting to be loaded at 1800 hours on [redacted]

25X1D
25X1D



25X1D The condition of the causeway is particularly interesting in this photographic sequence. The causeway had been made serviceable prior to ██████████ by repairing the damaged portions and substituting improved funds for those segments which had been completely destroyed. There was a marked deterioration of the causeway by the afternoon of the ██████████ 25X1D probably resulting from the extremely high volume of traffic during the day.

Transshipment Point No. 3, also on the south bank, exhibited relatively little activity during the Christmas period. At the same time 25X1D Point No. 2 was photographed on the morning of the ██████████ (Figure 12), the activity at Point No. 3 was limited to 1 sampen beached adjacent to several small stacks of supplies and personnel loading a single cargo truck. The deterioration of the causeway leading from Point No. 2 was not repaired prior to the New Year Truce, however, and Point No. 3 was the only transshipment point in use on the south bank during that period.

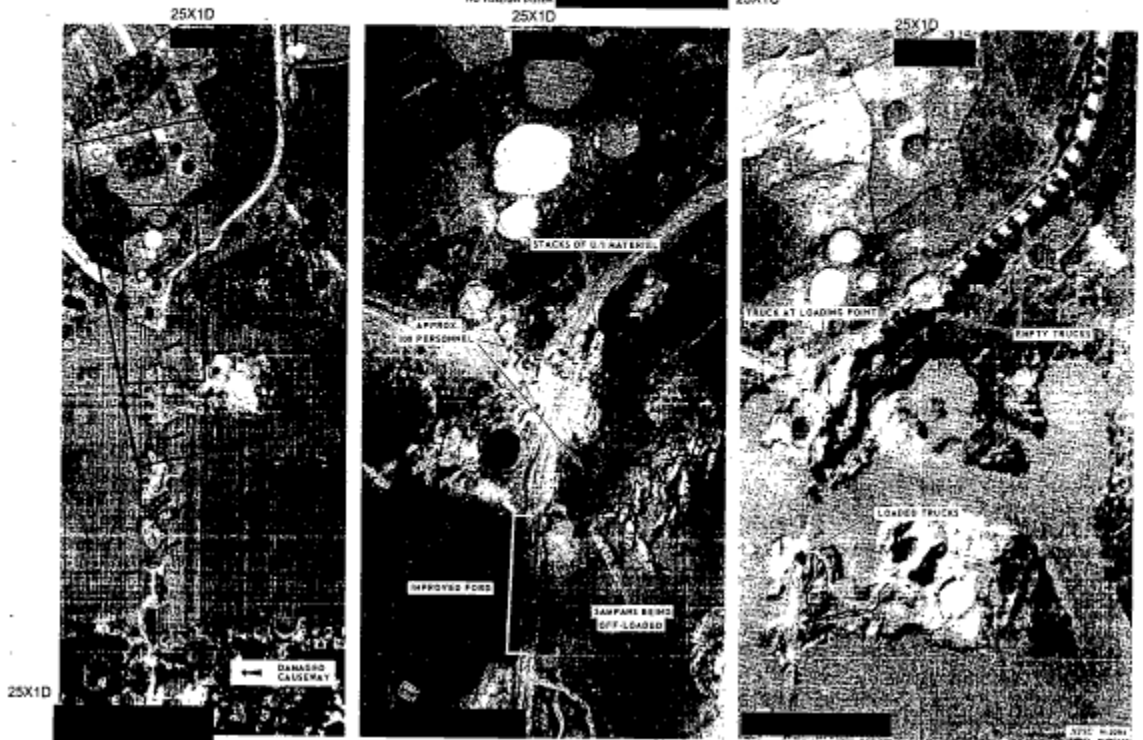
25X1D Transshipment Point No. 1, on the north bank of the Song Giang, probably provides the best example of the relative activity during all 3 truce periods. Figure 13 depicts a portion of the approximately 70 sampans, 250 personnel, and 6 cargo trucks involved in transshipping on the morning of ██████████ transshipment had been completed at this point by 1800 hours (Figure 1A). A comparable level of transshipping took place again during the New Year Truce Period (Figure 15), but the failure to suspend air strikes during Tet was reflected in the normal inactivity of ██████████ (Figure 16).

25X1D



~~SECRET~~

REF ID: A66666



25X1D FIGURE 12. TRANSHAYNHY POINT NO. 2 QUANG KHE, NORTH VIETNAM

Page 13

~~SECRET~~



SECRET

25X1C

NO FOREIGN DISSEM

REF ID: A66384

25X1D



25X1D

FIGURE 13. TRANSMISSION POINT NO. 1, QUANG BINH, NORTH VIETNAM

Page 13

SECRET

NO FOREIGN DISSEM

25X1C



25X1D



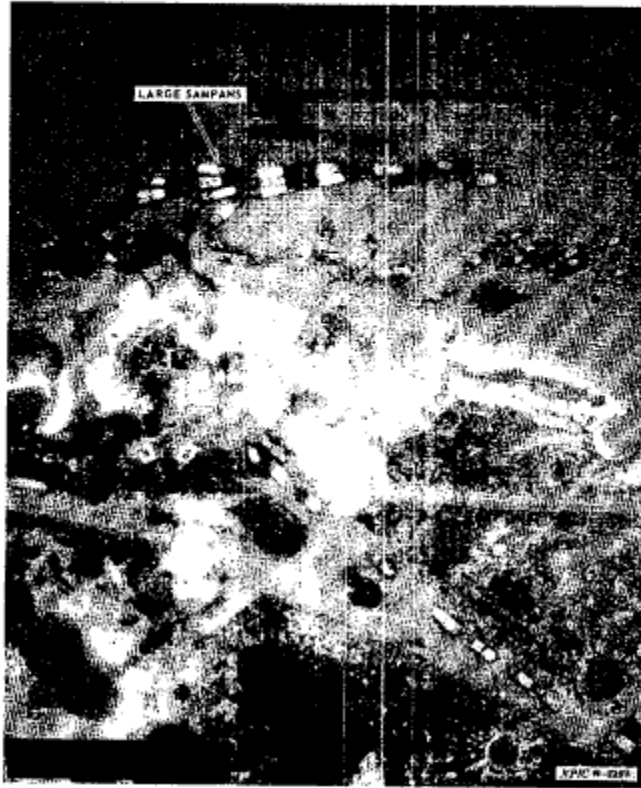
25X1D

FIGURE 14. TRANSHIPMENT POINT NO. 1 QUANG KHE, NORTH VIETNAM

Page 17



25X1D



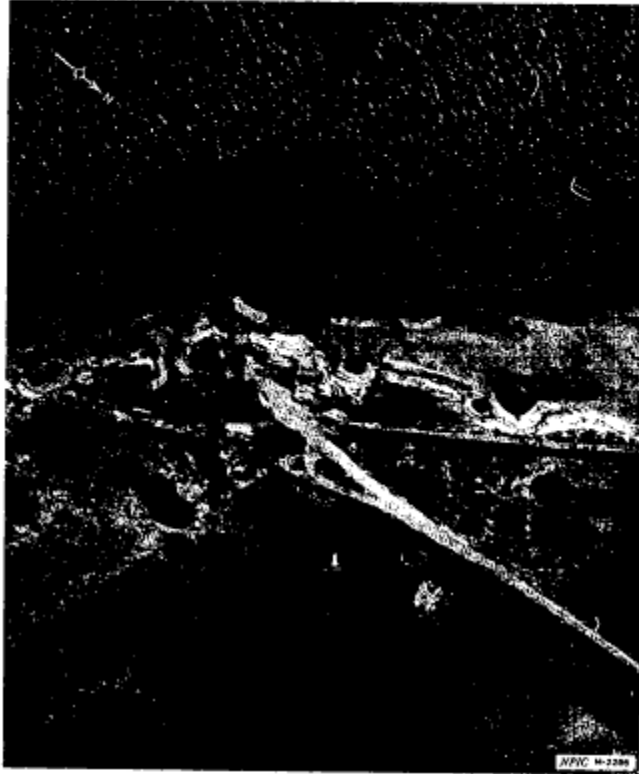
25X1D

FIGURE 15. TRANSHIPMENT POINT NO. 1 QUANG KHE, NORTH VIETNAM

Page 11



25X1D



25X1D

FIGURE 16. TRANSHIPMENT POINT NO. 1 (QUANG KHE, NORTH VIETNAM)

Page 19



Song Troc (River) Transshipment Points

The extensive amount of supplies stockpiled at 2 transshipment and storage facilities on the Song Troc (river), 4.5 nm west-southwest and 7.5 nm southwest of Quang Khe, indicate that these facilities were major components in the logistics network utilized during the truce periods. The strategic location of these facilities between Routes 137 and 1A permits the redistribution of supplies to both Laos and the DMZ area via these respective routes (see accompanying map). This is probably their normal function when supplies are moved south from the railhead of the serviceable Vinh/Doag Hoi Fail Line (17-49N 106-10E) along the Nguon May and Song Troc rivers.

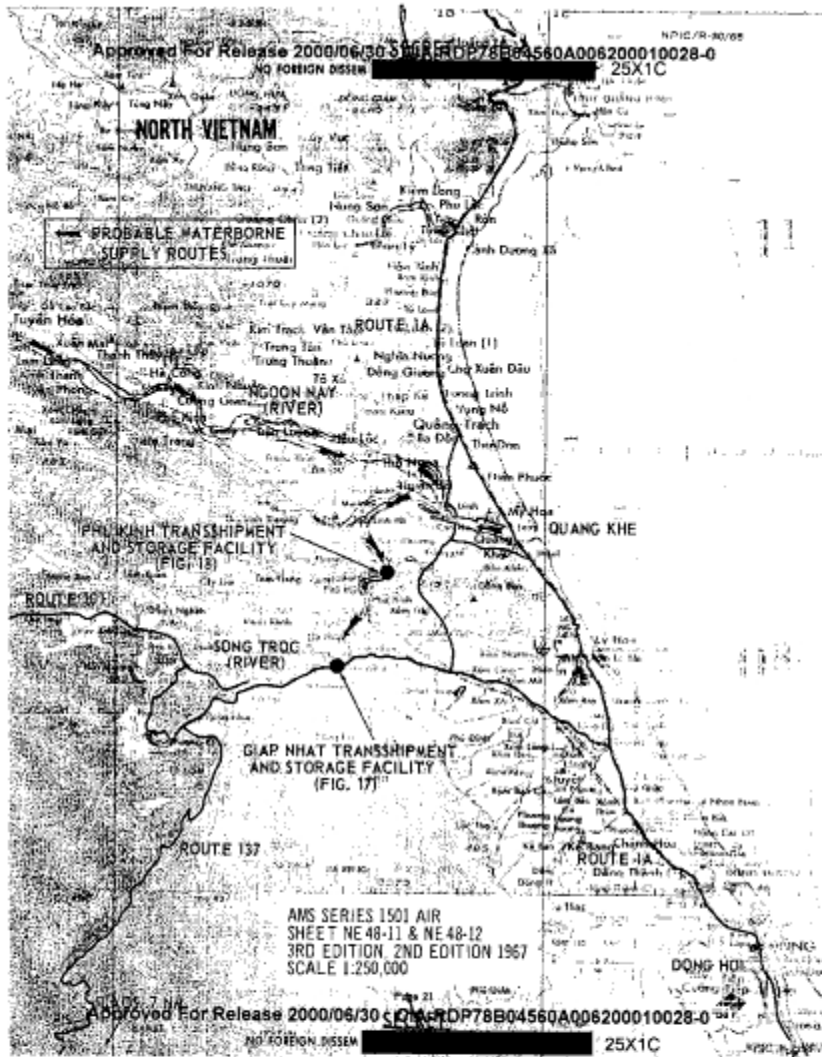
Two significant facts suggest that these facilities were directly involved in the transshipping activity at Quang Khe during the truce periods and that the supplies observed stockpiled on ██████████ were intended for Laos rather than the DMZ area. First, the 14 large sampans located at the northern Quang Khe transshipment point on ██████████ (Figure 15) were unlike any craft ever observed at the southern transshipment points. Second, an extremely large amount of supplies was observed stockpiled away from the river bank at the 2 facilities on the Song Troc later in the month (Figures 17 and 18). It seems reasonable to assume that at least most of these supplies which crossed the river at Quang Khe were intended for further movement south along Route 1A; while any supplies which were carried southwest along the Song Troc would be transhipped for further movement along Route 137.

25X1D
25X1D

A partially-submerged sampan appears to have been utilized as an offshore wharf at the Giap Nhat Transshipment Point (Figure 17). Although some residue of supplies remains scattered at the river bank and approximately 70 personnel are observed in the area, the movement to more permanent stockpiles appears nearly complete on the ██████████. In addition to those supplies stored in 2 buildings without roofs, 5 of the 8 stacks of supplies have been covered.

By the ██████████ supplies had been stockpiled in 16 separate stacks at the Fou Kinn Transshipment Point (Figure 18), and the area appeared void of activity. This was the first identification of this facility, and it is interesting to note that the access roads have been camouflaged with displaced vegetation.





25X1D



25X1D

FIGURE 17. GIAP NHAY TRANSHIPMENT POINT, SONG TRUC (RIVER), NORTH VIETNAM (17-37N 106-22E)

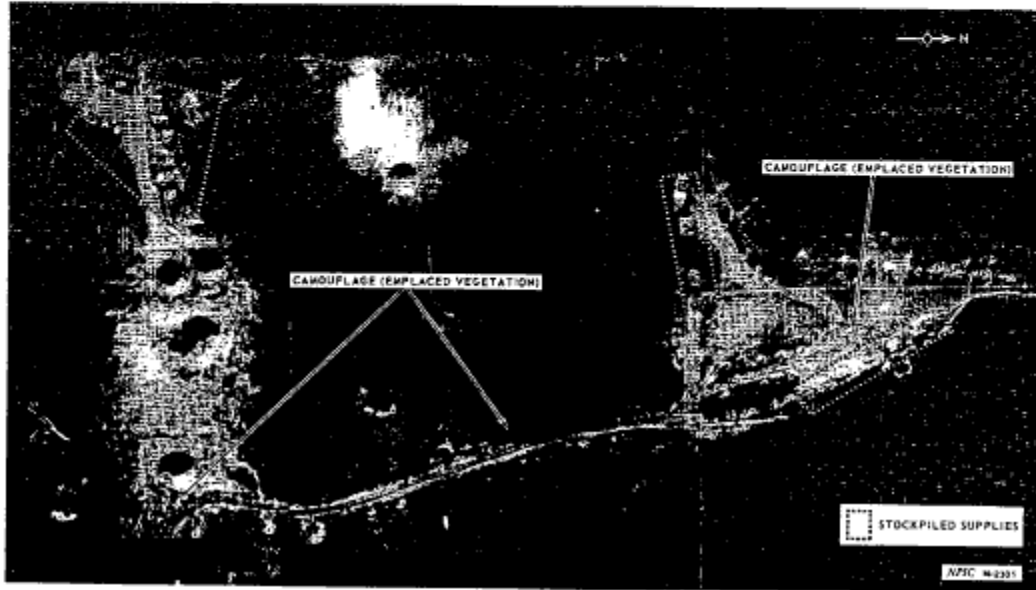
Page 22



NO FOREIGN DISSEM **SECRET** 25X1C

NPIC/R-80/88

25X1D



25X1D

FIGURE 15. PHU KINH TRANSHIPMENT POINT, SONG TROC (RIVER), NORTH VIETNAM (17-40N 106-24E)

Page 23

NO FOREIGN DISSEM **SECRET** 25X1C



~~SECRET~~

MPIC/R/30/88

NO FOREIGN DISSEM

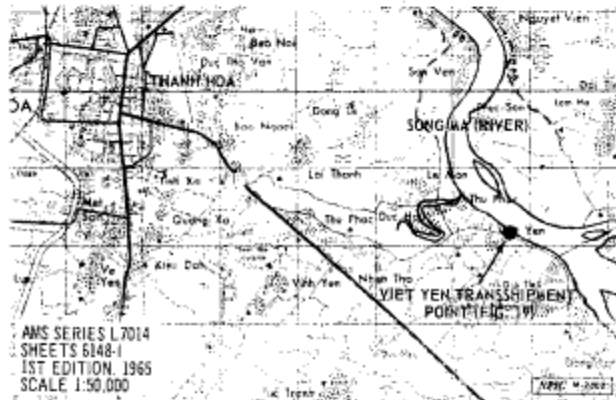
25X1C

Viet Yen Transshipment Point

The only transshipment operation identified in the areas of photographic coverage north of Quang Khe during the truce periods was located near Viet Yen, 3 km east-southeast of Thanh Hoa. Six probably motorized sampans, approximately 40 ft in length, were moored here on [REDACTED] (Figure 19). Eighteen canvas-covered stacks of supplies were located on the adjacent river bank, and 5 cargo trucks were in the immediate vicinity. Additional river craft were observed in the area, as well as in the normal concentrations throughout the Panhandle (approximately 950 sampans/junks were counted on [REDACTED]). However, it is difficult, if not impossible, to associate these with any special logistic effort.

25X1D

25X1D



Page 24

~~SECRET~~

NO FOREIGN DISSEM

25X1C



25X1D

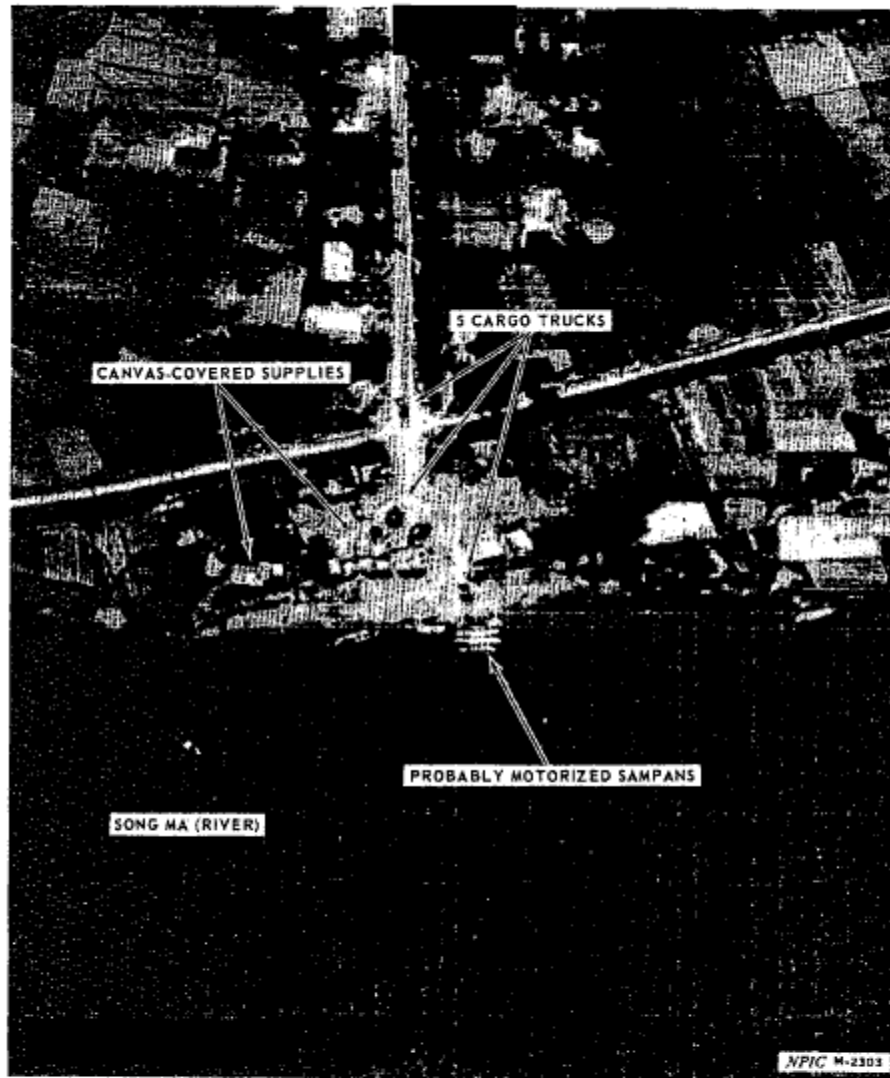
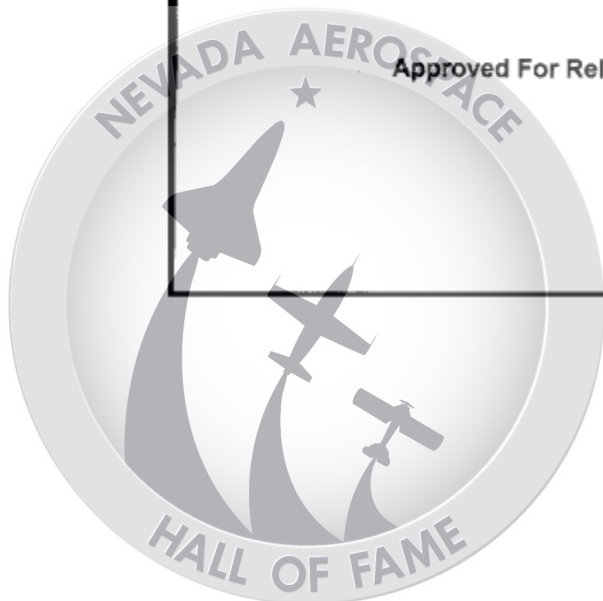


FIGURE 19. TRANSHIPMENT POINT, VIET YEN, NORTH VIETNAM (19-47N 105-49E)



Yen Phu Area Logistics Activity

Two major supply points were identified within 1 nm of Yen Phu during the Christmas and New Year Truce Periods and their location, precisely halfway between Thanh Hoa and Vinh, lends some credence to the reported shuttle system employed for the movement of supplies. In addition, the Route 1A alternate river crossings at Yen Phu provide one of the better comparisons of logistic support activity during truce and non-truce periods.

25X1D Sixteen large stacks of supplies were dispersed around a loop road within the village of Thien Ki, immediately north of Yen Phu, on [REDACTED] 25X1D (Figure 20). Although most of the supplies were covered, many apparent rice sacks were visible. Some of the supplies had been placed in partially dismantled huts, suggesting that other apparently native dwellings in the area were also being used for storage. Seven trucks were probably awaiting cargo at that time. By [REDACTED] 6 of 25X1D the stacks had been either removed or partially removed, and additional supplies had been stockpiled in a previously unused area.

25X1D Cargo trucks were also being loaded at the supply point immediately south of Yen Phu on [REDACTED] (Figure 21). In addition to the probable storage building adjacent to the trucks, 15 canvas-covered and open stacks of supplies (ranging from approximately 10 x 40 x 15 ft to 30 x 100 x 15 ft) were dispersed under a sparse tree canopy. At least 3 of 25X1D these stacks had been partially removed by [REDACTED]

25X1D Figure 22 depicts the normal daylight status of 2 Route 1A river crossings at Yen Phu. (A third alternate crossing remained unserviceable throughout the 2 truce periods and is not depicted.) Temporary pontoon bridges were positioned at these crossings on [REDACTED] and then 25X1D removed before the [REDACTED] (Figure 23). Only 1 of the bridges was repositioned for the New Year Truce and the resulting bottleneck was evident at the bridge (Figure 24) as well as 300 meters south (Figure 4).



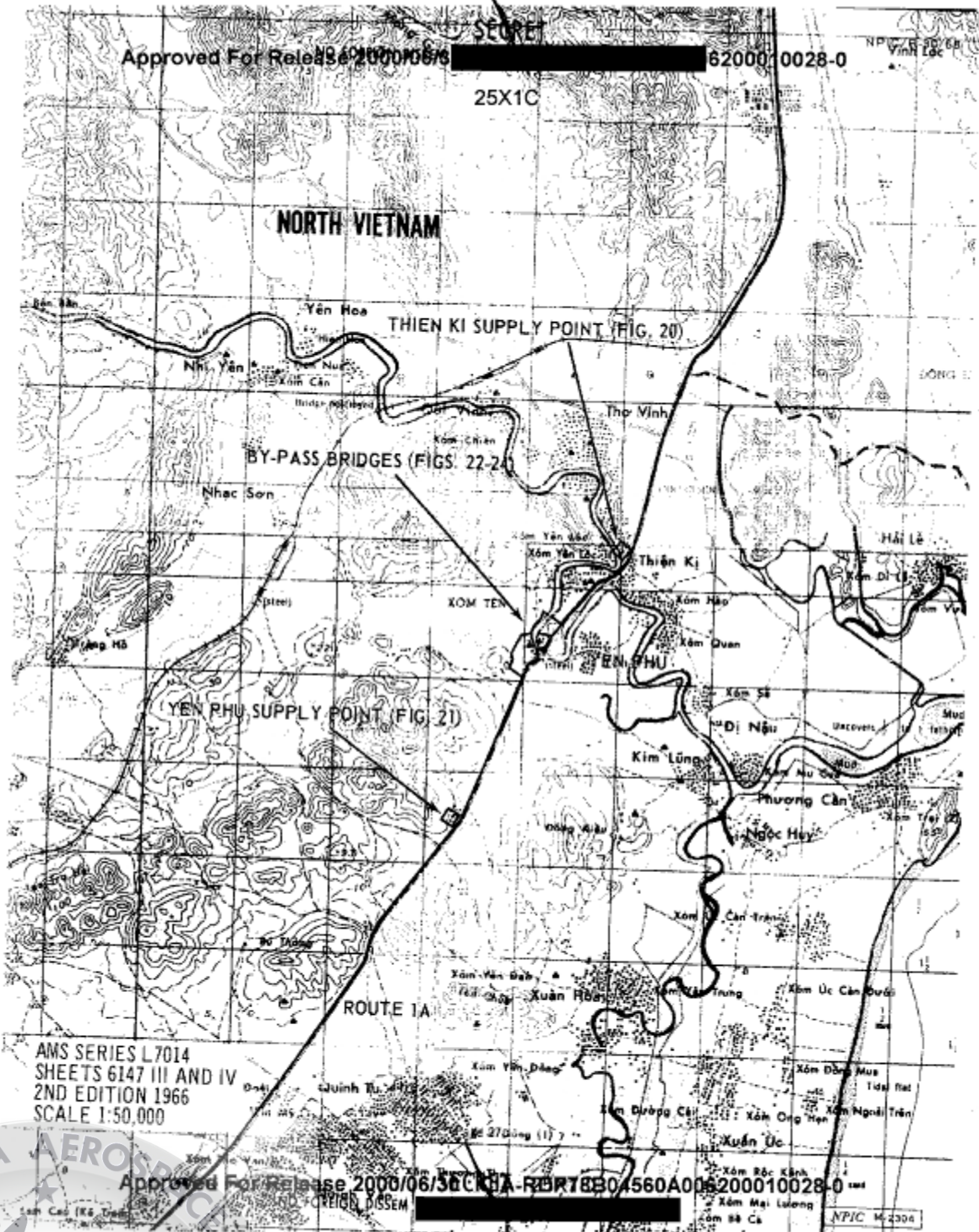
Approved For Release 2000/06/06 : CIA-RDP78B04560A006200010028-0

SECRET

62000 0028-0

25X1C

NORTH VIETNAM



AMS SERIES L7014
 SHEETS 6147 III AND IV
 2ND EDITION 1966
 SCALE 1:50,000

Approved For Release 2000/06/06 : CIA-RDP78B04560A006200010028-0

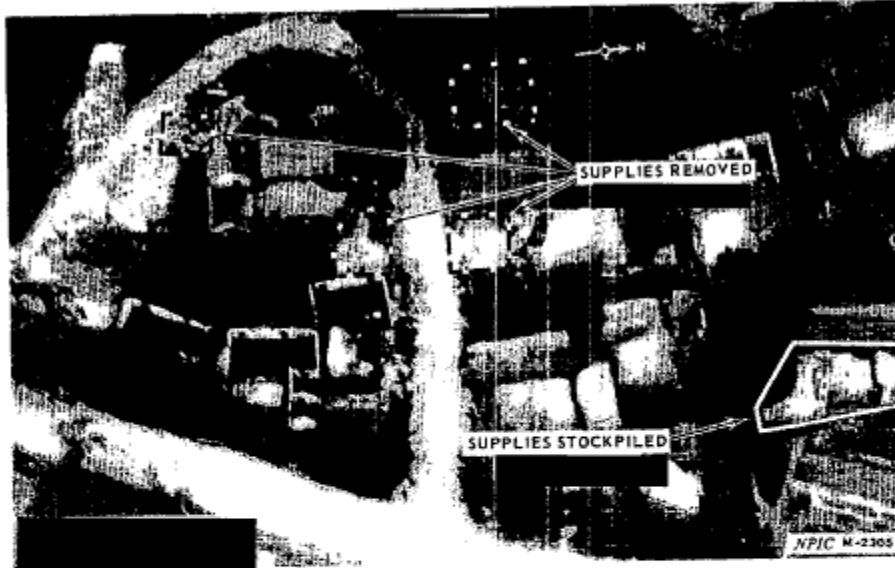


25X1D



25X1D

25X1D



25X1D

25X1D

FIGURE 20. THIEN KI SUPPLY POINT, ROUTE 1A, NORTH VIETNAM (19-15N 105-42E)

Page 28



25X1D



Approved For Release: 2000/06/30 : CIA-RDP78B04500A000200010028-0



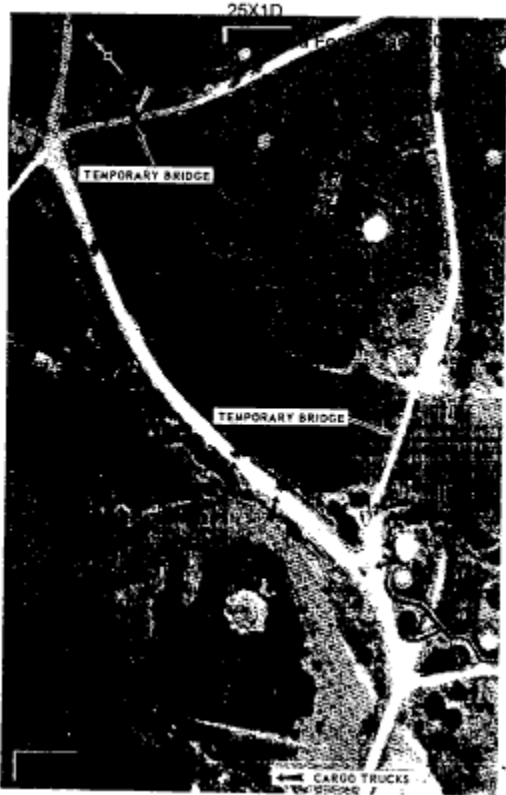
25X1D
Approved For Release 2000/06/30 : CIA-RDP78B04560A006200010028-0



25X1D

FIGURE 22. ALTERNATE RIVER CROSSINGS, ROUTE 1A, NORTH VIETNAM (19-14N 105-42E)
Approved For Release 2000/06/30 : CIA-RDP78B04560A006200010028-0

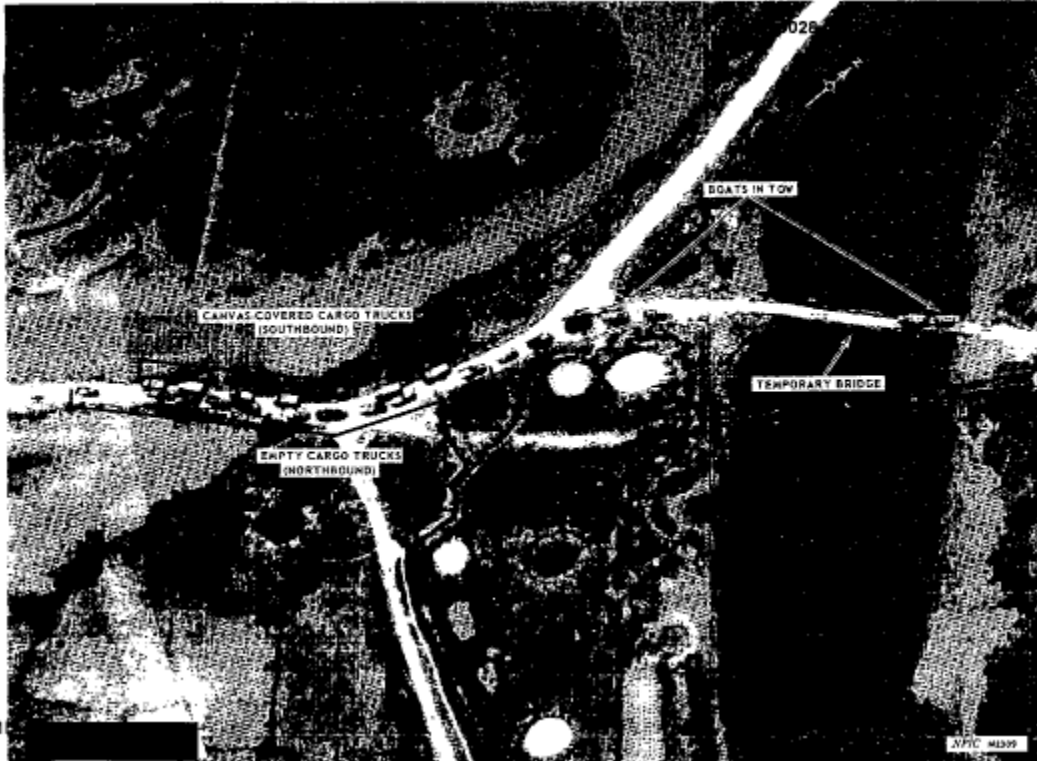




Approved For Release 2009/08/30 : CIA-RDP78B04560A0062000300028-0



25X1D



Approved For Release: 2000/06/30 : CIA-RDP78B04660R000200010028-0



Although not approaching the spectacular volume of vehicular activity, the observed daylight usage of the Ha Noi/Vinh Rail Line during the Christmas and New Year Truce Periods was both substantial and atypical. Large numbers of stationary rolling stock are frequently located along the line, [REDACTED]

25X1D

25X1D

25X1D

On [REDACTED] 3 short supply trains were observed moving on the rail line between Thanh Hoa and Vinh (Figures 25 and 26). As suggested by these photographs, ferries are utilized exclusively on this segment of the line, probably due to the inadequacy of the numerous small bridges to support the much heavier locomotives.

25X1D

The longest train observed moving during the 2 truce periods was headed south on [REDACTED] between Minh Binh and Thanh Hoa. This train included 11 camouflaged boxcars, 3 unladen-covered flatcars, and 2 covered gondolas (Figure 27). Another supply train, located 1.5 mi south of Minh Binh, was partially imaged on the same day and included 3 open gondolas filled with sacks of material, 1 boxcar, and 4 small PGL cars camouflaged as boxcars. Although this train was probably stationary, it is most unusual to photograph classified trains during the day.

Additional activity in the Minh Binh area during the New Year Truce included rail transshipping (Figure 28) and the positioning of 3 rail ferries to form a bridge across the Song Day (river). This was the first observation of a temporary rail bridge at this site, and it was not utilized again during Tet (Figure 30).

No trains, either moving or stationary, were observed during the Tet Truce Period. However, a northbound train was observed between Thanh Hoa and Minh Binh on [REDACTED] (Figure 29), and a ferry-pulled train was struck 30 mi south of Thanh Hoa on [REDACTED]

25X1D

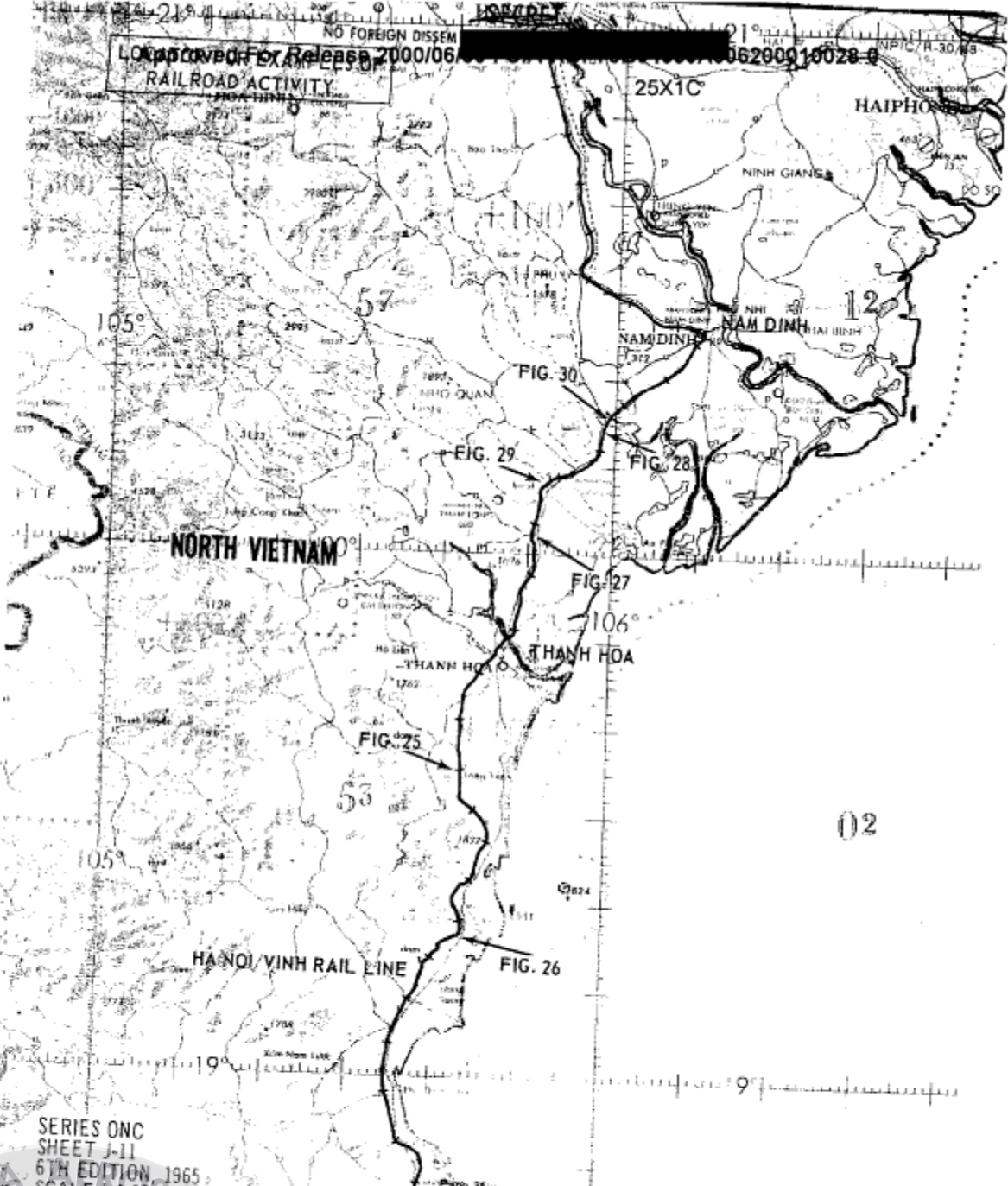
25X1D

25X1D

but together with other isolated examples referenced in this report, it suggests either a sense of urgency on the part of the North Vietnamese or a disdain for Allied bombing operations.



NO FOREIGN DISSEM
Approved For Release 2000/06/10 : CIA-RDP78B04560A006200010028-0
RAILROAD ACTIVITY

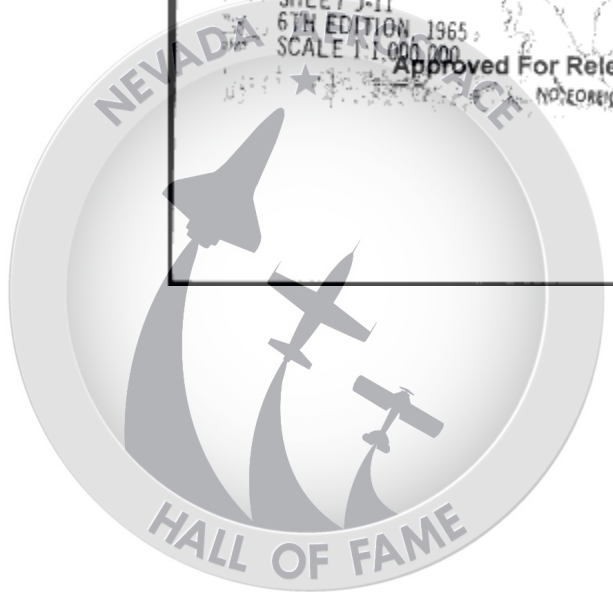


SERIES ONC
SHEET J-11
6TH EDITION 1965
SCALE 1:1,000,000

Approved For Release 2000/06/10 : CIA-RDP78B04560A006200010028-0
NO FOREIGN DISSEM
25X1C

02

NPIC M-2510

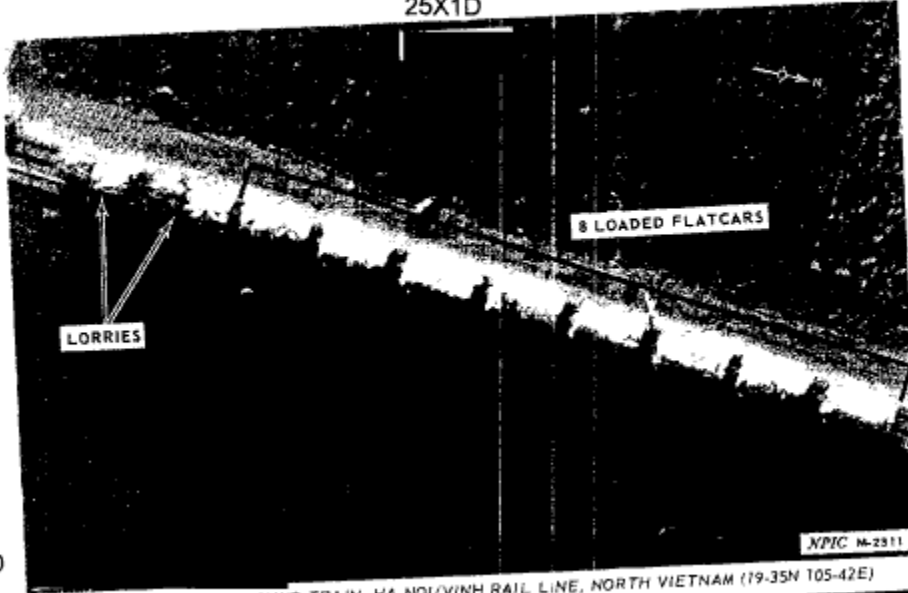


Approved For Release 2000/06/30 : CIA-RDP78B04560A006200010028-0

NO FOREIGN DISSEM

25X1C

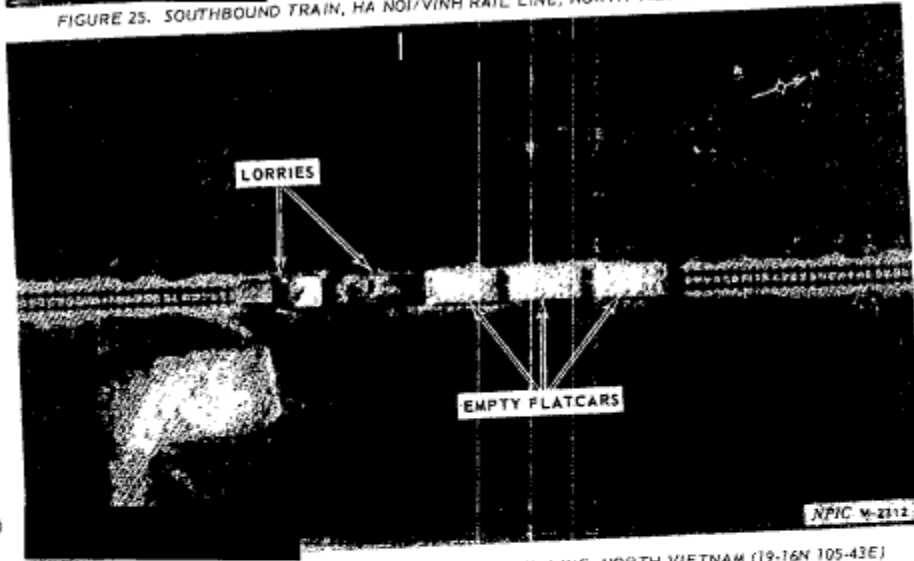
25X1D



25X1D

FIGURE 25. SOUTHBOUND TRAIN, HA NOI/VINH RAIL LINE, NORTH VIETNAM (19-35N 105-42E)

25X1D



25X1D

FIGURE 26. SOUTHBOUND TRAIN, HA NOI/VINH RAIL LINE, NORTH VIETNAM (19-16N 105-43E)

Approved For Release 2000/06/30 : CIA-RDP78B04560A006200010028-0

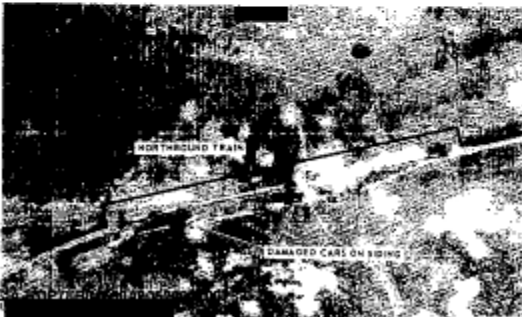
NO FOREIGN DISSEM

25X1C

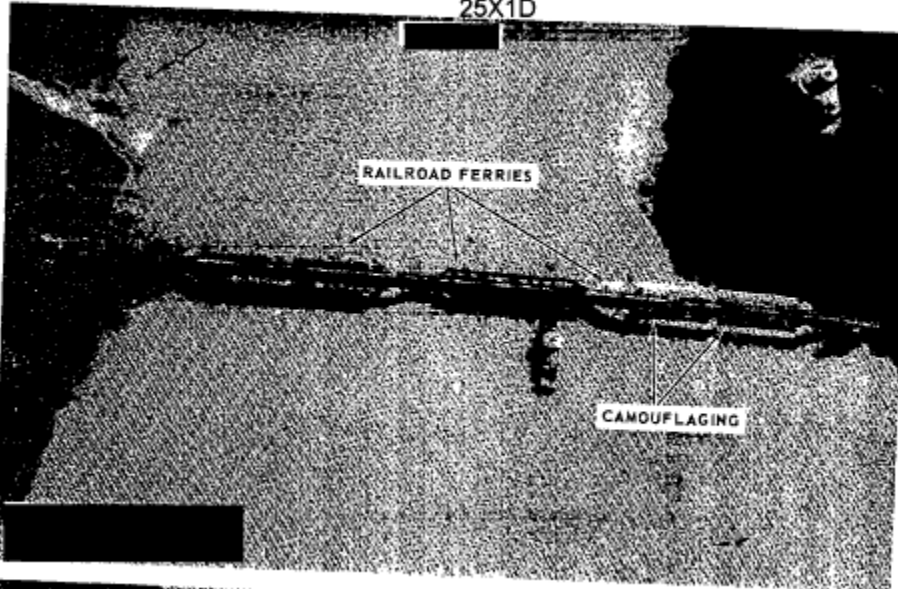




FIGURE 27. SOUTHBOUND SUPPLY TRAIN, HO CHI MINH RAIL LINE, NORTH VIETNAM (35 20N 104.37E)



25X1D



25X1D

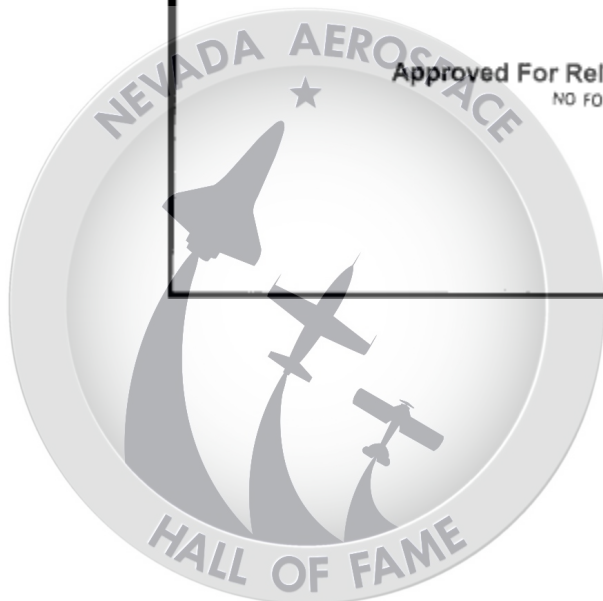
25X1D



25X1D

FIGURE 30. RAILROAD FERRY CROSSING AND TEMPORARY BRIDGE, NINH BINH, NORTH VIETNAM
(20-15N 105-59E)

Page 39



~~SECRET~~

NPIC/R-30/68

25X1C

APPENDIX

Page #1

~~SECRET~~

25X1C



NO FOREIGN DISSEM [REDACTED]

VEHICLE SIGHTINGS AND HEADINGS

25X1D	Route	Latitude (In Degrees)	Heading North	Heading South	Heading Undetermined*
[REDACTED]	1A	18 - 19	0	0	40
	1A	19 - 20	0	0	12
	12	20 - 21	0	0	21
	15	18 - 19	0	0	19
	108	18 - 19	0	0	30
	211	20 - 21	0	0	8
	Other		0	0	27
	Total		0	0	157
Christmas Truce	1A	17 - 18	69	109	7
	1A	18 - 19	3	46	0
	1A	19 - 20	244	205	86
	101	17 - 18	2	1	0
	104	17 - 18	4	2	0
	106	17 - 18	0	2	0
	107	17 - 18	1	4	0
	108	17 - 18	4	50	0
	110	17 - 18	3	2	2
	137	17 - 18	5	1	2
	194	19 - 20	0	6	0
	Total		337	396	97
New Year Truce	1A	17 - 18	44	63	56
	1A	18 - 19	0	0	0
	1A	19 - 20	341	277	59
	1A	20 - 21	18	26	0
	10	20 - 21	10	12	0
	107	19 - 20	0	4	0
	108	19 - 20	31	9	0
	701	19 - 20	11	9	0
	704	19 - 20	1	1	0
	Total		456	403	115

NO FOREIGN DISSEM [REDACTED]



25X1C

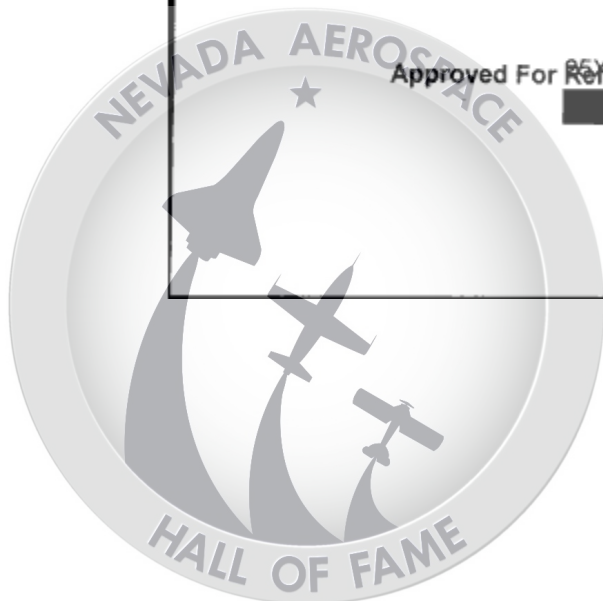
SECRET

[REDACTED]

	Route	Latitude (In Degrees)	Heading North	Heading South	Heading Undetermined*
Test Truce	1A	17 - 18	0	1	0
	1A	18 - 19	2	7	83
	1A	19 - 20	5	3	5
	1A	20 - 21	0	10	0
	7	18 - 19	0	0	4
	10	20 - 21	5	10	16
	15	17 - 18	0	1	0
	15	18 - 19	0	2	0
	21	20 - 21	0	0	1
	92	20 - 21	0	0	9
	101	17 - 18	0	1	3
	118	19 - 20	0	0	10
	151	18 - 19	0	0	3
	210	20 - 21	2	0	4
	706	19 - 20	0	0	3
	Total			14	35

*Sightings on east-west routes are included in this column.

[REDACTED]



NPIC BRIEFING BOARD REFERENCES

1966 Christmas Truce Period

L-2528 Truck Convoy, Route 701, NVN

1967 TET Truce Period

L-2725 Trucks, Route 1A, NVN
L-2727 Transshipment Operation, Quang Khe, NVN
L-2728 Truck Convoy, Mu Gia Pass Area, NVN
L-2729 Truck Convoys, Mu Gia Pass Area, NVN
L-2754 Truck Convoys, Mu Gia Pass Area, NVN

1967 Christmas Truce Period

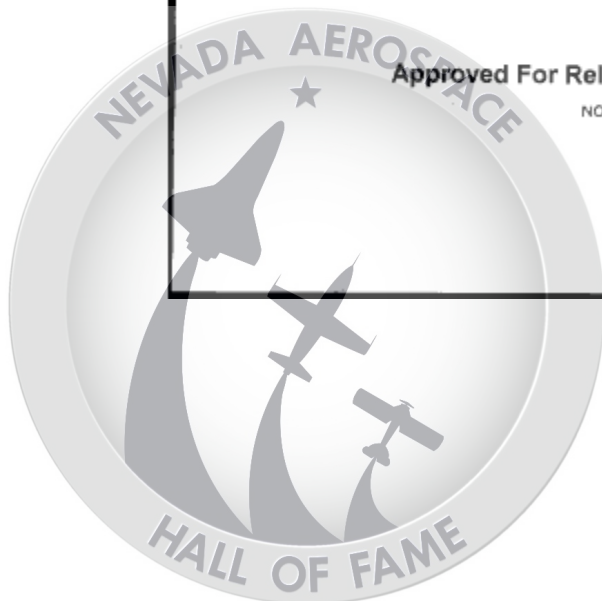
L-4721 Transshipment Activity (Morning), Quang Khe, NVN
L-4722 Supply Point, Thien Ki, NVN
L-4723 Transshipment Activity (Afternoon), Quang Khe, NVN
L-4724 By-Pass Bridges, Yen Phu, NVN
L-4725 River Crossing Activity, Non, NVN
L-4726 Rail Activity, Thanh Hoa Area, NVN
L-4727 Christmas Truce Activity
L-4728 Supply Point, Yen Phu, NVN
L-4729 Transshipment Point, Viet Yen, NVN
L-4733 Vehicle Activity, NVN

1968 New Year Truce Period

L-4740 Transshipment Activity, Quang Khe, NVN
L-4746 Waterborne Activity, Thanh Hoa Area, NVN
L-4747 Vehicle Activity, New Years Truce, NVN
L-4749 Rail Activity, Minh Binh-Thanh Hoa Area, NVN
L-4750 New Years Truce Activity, NVN
L-4751 By-Pass Bridge, Yen Phu, NVN
L-4753 Supply Points, Yen Phu/Thien Ki, NVN

1968 Pre-Tet Period

L-4819 Rail Activity, Minh Binh-Thanh Hoa Area, NVN
L-4820 Road Repair, Route 15, NVN
L-4828 Transshipment Point, Giap Nhat, NVN
L-4829 Transshipment Point, Song Vinh/Huong Mai, NVN

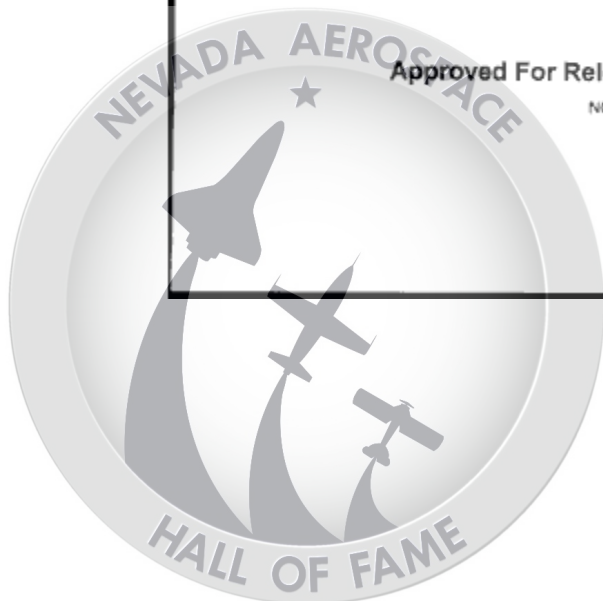
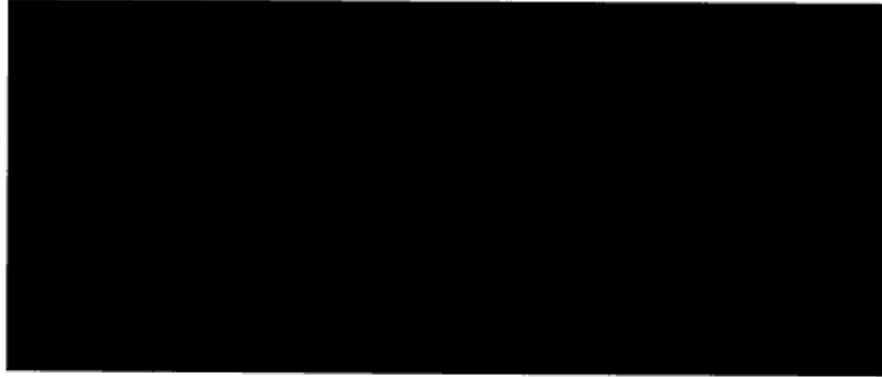


1968 Tet Truce Period

L-4812 Transshipment Points, Quang Khe, NVN
L-4817 Vehicles in Village Sanctuaries, NVN
L-4826 Rail Activity, Ninh Binh, NVN
L-4827 Vehicle Activity NVN

MISSION REFERENCES

25X1D



Approved For Release 2000/06/30 : CIA-RDP78B04560A006200010028-0
NO FOREIGN DISSEM ~~SECRET~~ 25X1C

Approved For Release 2000/06/30 : CIA-RDP78B04560A006200010028-0
NO FOREIGN DISSEM ~~SECRET~~ 25X1C



Title:	PHASEOUT HISTORY
Abstract:	
Pages:	0002
Pub Date:	3/7/1968
Release Date:	7/17/2001
Keywords:	OXCART SR-71 BLACKBIRD BLACK SHIELD A-12
Case Number:	F-2000-01388
Copyright:	0
Release Decision:	RIFPUB
Classification:	U



~~SECRET~~
DRAFT

25X1A

7 March 1968

PHASEOUT HISTORY

1. During 1966 a study entitled "Advanced Reconnaissance Aircraft History" was accomplished. The study group was designated by the Secretary of Defense, the Director of the Budget, and the DCI to make an appraisal of the A-12 (OXCART) and SR 71 aircraft flights. After consideration of several alternatives, the study concluded that the A-12 flight should be mothballed effective 31 December 1967. The report based its findings on these assumptions:

- a. The SR-71 was to be fully operational by October 1967.
- b. The difference in operational altitude and speed were irrelevant.
- c. A savings over a five-year period [redacted] would be accomplished.

25X1A

2. Subsequent to the decision to close out the OXCART program, it was decided to deploy the A-12 to [redacted] 25X1A

25X1A

[redacted] for the primary purpose of overflight of North Viet Nam. The SR-71 vehicle did not obtain an operationally ready status at the expected time and the OXCART program has been extended twice. The decision to extend the OXCART



Page 2

program for 3 months occurred on 23 October 1967. This extended the program through 31 March 1968. On 29 December 1967 the OXCART program was extended through 30 June 1968 with an overlap of one month duration with the SR-71 for photographic coverage of SE Asia. The SR-71 is now scheduled to deploy to ██████████ and to be operationally ready for assumption of primary responsibility for the SE Asia reconnaissance mission by 15 March. The OXCART vehicle will remain deployed to ██████████ until 30 days after the SR-71 assumes the primary responsibility after which it will be redeployed to the United States at ██████████. The OXCART program will maintain operational readiness through 30 June 1968 after which the aircraft will be stored and the program terminated.

25X1A

25X1A

25X1A



Title:	PRELIMINARY ASSESSMENT OF BLACK SHIELD MISSION 68 OVER NORTH KOREA
Abstract:	
Pages:	0005
Pub Date:	1/29/1968
Release Date:	9/10/2001
Keywords:	ARMED FORCES KOREA ASSESSMENT INDUSTRIAL NORTH KOREA MISSION COUNTRY PHOTOGRAPHY TRANSPORTATI SYSTEM BASE BLACK SHIELD
Case Number:	EO-2001-00204
Copyright:	0
Release Decision:	RIPPUB
Classification:	U



NLJ.018.028.005/14

TAB III

~~SECRET~~

~~No Foreign Dissem~~

67

APPROVED FOR RELEASE
DATE: SEP 2001

29 January 1968

EO 12958 3.4(b)(1)-25Yrs
(S)

MEMORANDUM

SUBJECT: Preliminary Assessment of BLACK SHIELD
Mission 6847 over North Korea

Summary

BLACK SHIELD Mission 6847, flown over North
Korea on 26 January 1968, obtained photography

EO 12958 3.4(b)(1)-25Yrs
(S)

[REDACTED]

EO 12958 3.4(b)(1)-25Yr
(S)

[REDACTED]

EO 12958 3.4(b)(1)-25Yrs
(S)

[REDACTED] coverage was obtained of both North Korean
and ROK military forces and activity along the DMZ.
No North Korean ground forces build-up was observed
in or near the DMZ. The North Korean surface-to-
air missile defenses appear to be in a high state
of readiness. The USS Pueblo was anchored in an
inlet in Wonsan Bay, attended by two North Korean
patrol boats and guarded by three Komars.

Note: This memorandum was prepared by the Directorate
of Intelligence.

~~No Foreign Dissem~~
~~SECRET~~

XEROX FROM QUICK COPY



USS Pueblo

1. The Pueblo is at an offshore anchorage in a small, isolated bay north of Wonsan with two North Korean patrol boats anchored alongside. No damage to the Pueblo is discernible. There is no evidence of activity around the Pueblo, with the exception of the two patrol boats.

Ground Forces

2. Ground force activity along the DMZ and northward as far as the center of the country looked normal, and no major concentrations of forces or significant movements were seen. The North Korean side of the DMZ, however, contains large numbers of tunnels, caves, and underground facilities which make determination of force and equipment levels difficult. [REDACTED]

EO 12958 3.4(b)(1)-25Yrs
(S)

3. Along the ROK side of the DMZ there was more evidence of vehicle movements and equipment concentrations, in contrast to the highly dispersed, fairly static, and largely underground dispositions on the North Korean side.

Air Forces

4. Eight of the most important of the 15 North Korean military airfields were covered by this mission and aircraft dispositions were in accord with previous estimates. The number of fighter aircraft seen was in some instances below the present order of battle, but many aircraft were probably concealed in the extensive system of underground hangars.

5. At Pukchang-ni Airfield, [REDACTED] 51 fuselage shipping crates--probably for the MIG-17 Fresco--were seen. If these crates were delivered recently, their delivery would add a new dimension to the current aircraft procurement program of

EO 12958 3.4(b)(1)-25Yrs
(S)



~~SECRET~~

North Korea, which has been re-equipping with the more advanced MIG-21/Fishbed supplied by the USSR. There has been no evidence of an emergency delivery since the current crisis began.

6. The main IL-28 jet light bomber base at Uiju near the Chinese border was not covered, but there is no evidence that any of these aircraft have deployed toward the DMZ. The normal complement of IL-28s was seen at Sunan near Pyongyang, the other IL-28 base.

Naval Activity

7. About half of North Korea's naval force was seen by this mission. No unusual vessel deployments or build-ups were seen along the southern half of the east and west coasts.

8. Seven of North Korea's eight Komar guided-missile patrol boats were in their normal operating area near Wonsan, three of them apparently guarding the small bay where Pueblo is anchored.

9. A new support base for the Komar squadron and its Styx missiles was identified on a peninsula in the Wonsan area. The base consists of a missile support facility, docking areas for the boats, and underground storage. As many as 30 Styx missile crates can be seen in the missile support area. The docking area includes a pier and a sea-level tunnel. The sea-level tunnel is probably the entrance to an underground dock large enough for Komar boats. A passageway through the ice to the tunnel has been kept clear. For the past couple of years the North Koreans have been particularly sensitive to air reconnaissance of this general area.

10. The mission provided no major changes to the naval order-of-battle in the areas covered, with the exception of the presence of two Shershen-class torpedo boats in the Wonsan area. The Shershen is the most modern Soviet torpedo boat, and these vessels were probably supplied by the USSR as part of its military aid program to North Korea.

-3-

~~No Foreign Dissem.~~
~~SECRET~~



~~SECRET~~
~~No Foreign Dissem~~

11. The four W-class torpedo attack submarines in the North Korean Navy were not seen.

Railway and Road Activity

12. Examination of major roads and railways from the DMZ northward discloses no evidence of unusual movements or major troop or supply build-ups. Immediately north of the DMZ, no unusual truck convoys were on the major roads and the level of activity in the rail yards at the southern termini of the lines was normal.

13. Further to the north, in the industrialized portions of North Korea, more road and rail activity was observed. The amount of rail activity on the main lines and in the principal rail yards is considered normal, however, and is probably serving routine economic and industrial needs. Road traffic also appears to be at normal levels. No unusual rail or road activity was evident in the Wonsan area.

Surface-to-Air Missile Defenses

14. The North Korean surface-to-air missile (SAM) sites are probably completely operational and appear to be in a high state of readiness. Thirteen of the 14 known sites were covered, and equipment was observed at all sites. One to three missiles were on launchers at all but one of the sites, and roads were clear of snow. No new sites have been detected so far. The SAM support area at Pyongyang was also covered, but no unusual activity was noted.

Coastal Defense Cruise Missiles

15. The known Samlet coastal defense cruise missile site at Nampo on the west coast was covered and some vehicles were observed. Disruptive painting has been used to camouflage some of the buildings. Across the bay on the northern side a possible cruise missile site was newly identified. Past photography shows that this site has been there

-4-

~~No Foreign Dissem~~
~~SECRET~~



~~SECRET~~
~~No Foreign Dissem~~

since 1965 and no equipment has been observed, suggesting that it is inactive. No other coastal defense cruise missile sites have been identified in North Korea.

Industry and Transportation

16. Extensive coverage was obtained of North Korea's major industrial complexes and major transportation networks--road, rail, and water--in the southern half of the country. All the industrial complexes examined were active, but there is no unusual activity. North Korea's major petroleum storage facilities were not covered by this mission, but the smaller sites in the southern part of the country show no evidence of recent expansion or unusual activity. None of the five North Korean merchant ships can be identified in the ports covered.

-5-

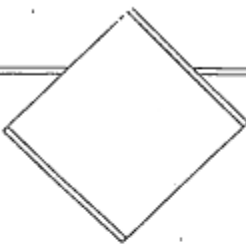
~~No Foreign Dissem~~
~~SECRET~~



Title:	(EST. PUB DATE) THE U-2'S INTENDED SUCCESSOR: PROJECT OXCART, 1956-1968
Abstract:	
Pages:	0055
Pub Date:	12/31/1968
Release Date:	9/12/2001
Keywords:	U-2 OXCART U2 A-12 AIRCRAFT CIA AIRCRAFTS
Case Number:	F-2000-01514
Copyright:	0
Release Decision:	RIPPUB
Classification:	U



NR0
#3



The U-2's Intended Successor:
Project OXCART,
1956-1968

Before the U-2 became operational in June 1956, CIA project officials had estimated that its life expectancy for flying safely over the Soviet Union would be between 18 months and two years. After overflights began and the Soviets demonstrated the capability of tracking and attempting to intercept the U-2, this estimate seemed too optimistic. By August 1956, Richard Bissell was so concerned about the U-2's vulnerability that he despaired of its ability to avoid destruction for six months, let alone two years.

To extend the U-2's useful operational life, project officials first attempted to reduce the aircraft's vulnerability to detection by Soviet radars. Project RAINBOW's efforts to mask the radar image of the U-2 not only proved ineffective, but actually made the aircraft more vulnerable by adding extra weight that reduced its maximum altitude. Because Soviet radar operators continued to find and track U-2s equipped with antiradar systems, the CIA canceled Project RAINBOW in May 1958.

Long before the failure of Project RAINBOW, Richard Bissell and his Air Force assistant, ██████████ had begun to look for a more radical solution to the problem of Soviet radar detection—an entirely new aircraft. In the late summer of 1956, the two officials visited a number of airframe contractors in a search for new ideas. Among the more unusual was Northrop Aviation's proposal for a gigantic aircraft with a very-high-lift wing. Because it would not be made of metal, the wing would require a type of bridge truss on its upper side to give it rigidity. The proposed aircraft would achieve

APPROVED FOR RELEASE

Approved for Release
Date 18 OCT 1994

2a





altitudes of 80,000 to 90,000 feet but only at subsonic speeds, just enough to keep it airborne.¹

The slow-flying Northrop design did not solve the problem of radar detection, and in 1957 the emphasis switched to supersonic designs. In August 1957, ~~the CIA's Office of Special Operations (OSO)~~ ~~that had been working on ways to reduce the~~ U-2's vulnerability to radar, began to investigate the possibility of designing an aircraft with a very small radar cross section. ~~It~~ soon discovered that supersonic speed greatly reduced the chances of detection by radar.² From this point on, the CIA's attention focused increasingly on the possibility of building an aircraft that could fly at both extremely high speeds and high altitudes while incorporating the best ideas in radar-absorbing or radar-deflecting techniques.

THE EVALUATION OF DESIGNS FOR A SUCCESSOR TO THE U-2

By the autumn of 1957, Bissell and ~~OSO~~ had collected so many ideas for a successor to the U-2 that Bissell asked DCI Dulles for permission to establish an advisory committee to assist in the selection process. Bissell also felt that the support of a committee of prominent scientists and engineers would prove useful when it came time to ask for funding for such an expensive project. Edwin Land became the chairman of the new committee, which included some of the scientists and engineers who had served on previous advisory bodies for overhead reconnaissance: Edward Purcell, Allen F. Donovan, H. Guyford Stever, and Eugene P. Kiefer. The Air Force's chief scientist, Courtland D. Perkins, was also a member. The committee first met in November 1957 and held six more meetings between July 1958 and the late summer of 1959. The meetings usually took place in Land's Boston office and almost always included the Air Force's Assistant Secretary for Research and Development, Dr. Joseph V. Charyk, and his Navy counterpart, Garrison Norton. Designers from several aircraft manufacturers also attended some of the meetings.³

¹ Donovan interview (S).

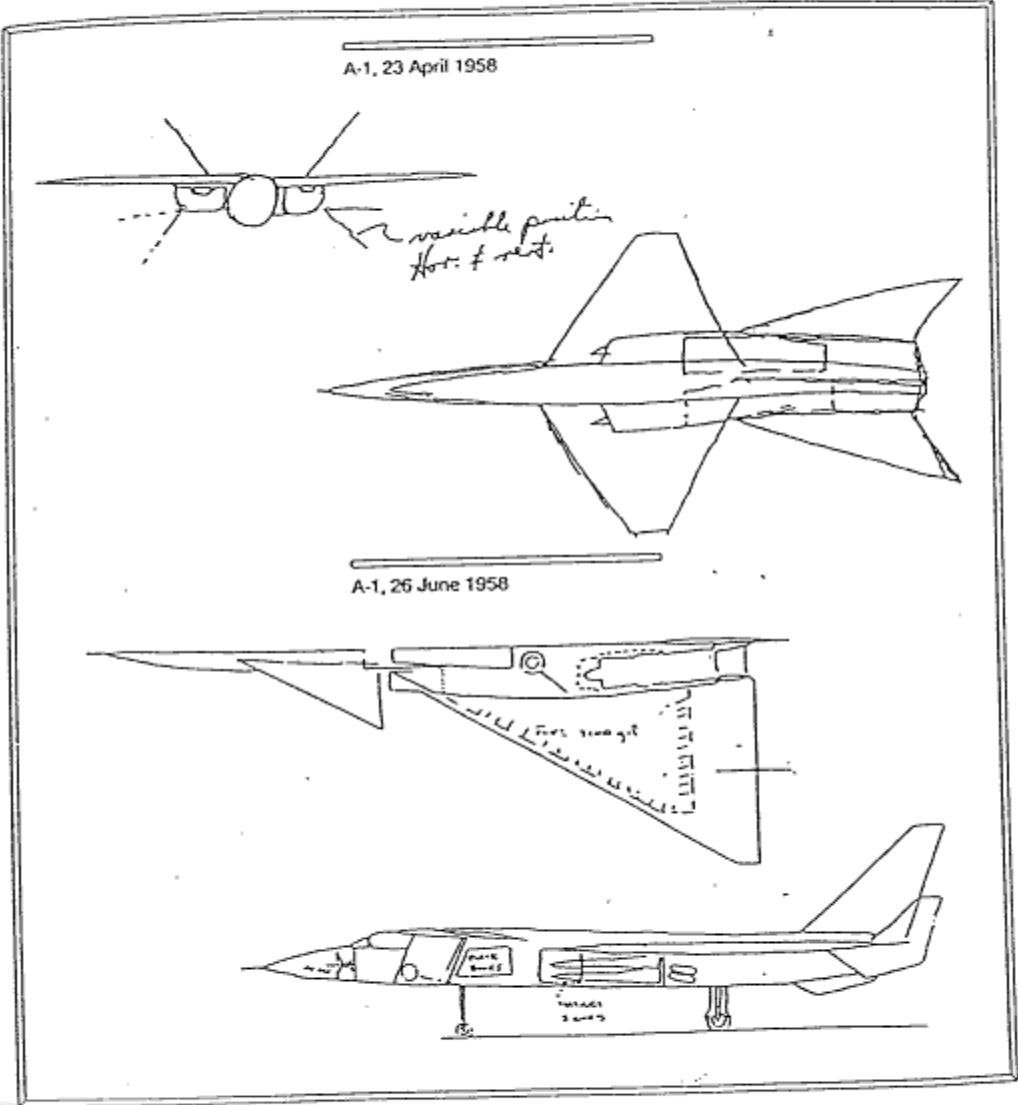
~~Clarence L. Johnson~~, "The OXCART Story," *Studies in Intelligence* 15 (Winter 1971):2

³ Clarence L. Johnson, Report No. SP-1362, "History of the OXCART Program," Lockheed Aircraft Corporation, Burbank, CA, 1 July 1968, p. 1 (TS Codeword).

TOP SECRET FOR RELEASE



~~SECRET~~
~~SECRET~~



Johnson's first drawing of the "U-3" (A-1); revised version of the A-1

APPROVED FOR RELEASE



The two most prominent firms involved in the search for a new aircraft were Lockheed, which had designed the successful U-2, and Convair, which was building the supersonic B-58 "Hustler" bomber for the Air Force and also working on an even faster model known as the B-58B "Super Hustler." Early in 1958, Richard Bissell asked officials from both firms to submit designs for a high-speed reconnaissance aircraft. During the spring and summer of 1958, both firms worked on design concepts without government contracts or funds.

Following extended discussions with Bissell on the subject of a supersonic successor to the U-2, Lockheed's Kelly Johnson began designing an aircraft that would cruise at Mach 3.0 at altitudes above 90,000 feet. On 23 July 1958, Johnson presented his new high-speed concept to Land's advisory committee, which expressed interest in the approach he was taking. At the same meeting, Navy representatives presented a concept for a high-altitude reconnaissance vehicle that examined the possibility of developing a ramjet-powered, inflatable, rubber vehicle that would be lifted to altitude by a balloon and then be propelled by a rocket to a speed where the ramjets could produce thrust. Richard Bissell asked Johnson to evaluate this concept, and three weeks later, after receiving more details from Navy representatives, Kelly Johnson made some quick calculations that showed that the design was impractical because the balloon would have to be a mile in diameter to lift the vehicle, which in turn would need a wing surface area greater than one-seventh of an acre to carry the payload.⁴

By September 1958, Lockheed had studied a number of possible configurations, some based on ramjet engines, others with both ramjets and turbojets. Personnel at Lockheed's Skunk Works referred to these aircraft concepts as "Archangel-1," "Archangel-2," and so forth, a carryover from the original nickname of "Angel" given to the U-2 during its development. These nicknames for the various designs soon became simply "A-1," "A-2," etc.

In September 1958, the Land committee met again to review all the concepts then under consideration and to winnow out the few that were most practicable. Among the concepts rejected were the Navy's proposal for an inflatable, ramjet-powered aircraft, a Boeing proposal for a 190-foot-long hydrogen-powered inflatable aircraft, and a

⁴ Clarence L. Johnson, "Development of the Lockheed SR-71 Blackbird," *Studies in Intelligence* 26 (Summer 1982):4 (U); Johnson, "Archangel log," 23 July 1958, 14 August 1958.

APPROVED FOR RELEASE



Lockheed design for a hydrogen-powered aircraft (the CL-400). The committee examined two other Kelly Johnson designs at this meeting—a tailless subsonic aircraft with a very-low-radar cross section (the G2A) and a new supersonic design (the A-2)—and did not accept either one, the former because of its slow speed and the latter because of its dependence on exotic fuels for its ramjets and its overall high cost. The committee approved the continuation of Convair's work on a ramjet-powered Mach 4.0 "parasite" aircraft that would be launched from a specially configured version of the B-58B bomber. The design was termed a parasite because it could not take off on its own but needed a larger aircraft to carry it aloft and accelerate it to the speed required to start the ramjet engine. The Convair design was called the FISH.³

Two months later, after reviewing the Convair proposal and yet another Lockheed design for a high-speed reconnaissance aircraft (the A-3), the Land committee concluded in late November 1958 that it would indeed be feasible to build an aircraft whose speed and altitude would make radar tracking difficult or impossible. The committee, therefore, recommended that DCI Dulles ask President Eisenhower to approve further pursuit of the project and to provide funds for additional studies and tests.⁴

On 17 December 1958, Allen Dulles and Richard Bissell briefed the President on the progress toward a successor to the U-2. Also present were Land and Purcell from the advisory committee, Presidential Science Adviser James Killian, and Air Force Secretary Donald Quarles. DCI Dulles reviewed the results of the U-2 missions to date and stated his belief that a successor to the U-2 could be used all over the world and "would have a much greater invulnerability to detection."

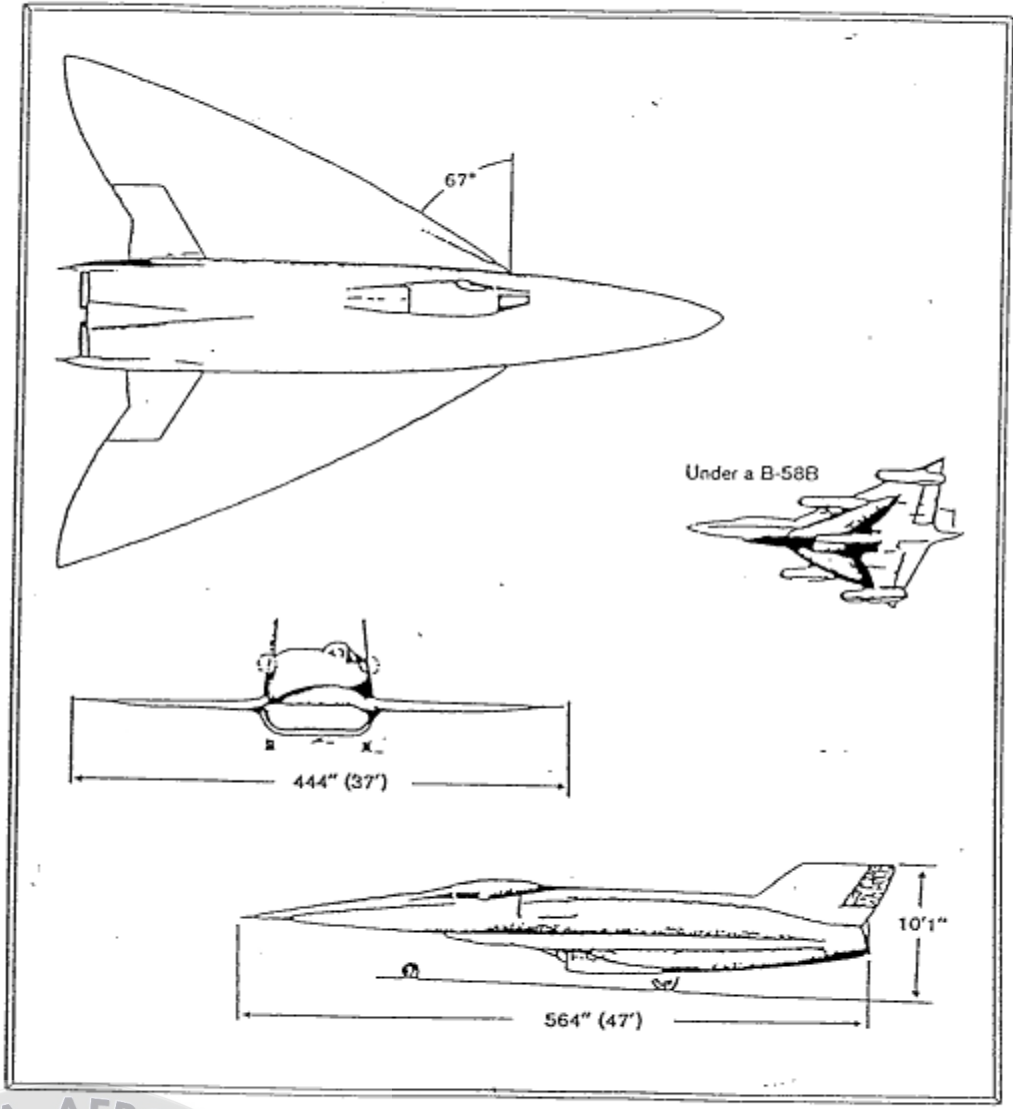
Bissell then described the two competing projects by Lockheed and Convair, noting that the chief question at the moment was whether to use air launch or ground takeoff. The next phase, he added, would be detailed engineering, at the end of which it was proposed that 12 aircraft be ordered at a cost of about \$100 million.

³ OSA History, chap. 20, p. 8 (Johnson, "Archangel log," 17-24 September 1958).

⁴ OSA Chronology, p. 21 (Johnson, "OXCART Story," p. 3); OSA History, chap. 20, p. 8 (Johnson, "Archangel log," 12 November 1958).

APPROVED FOR RELEASE





APPROPRIATE FOR RELEASE

Kelly Johnson's A-2 Design

Prepared	Sept 20, 58	DATE	LOCKHEED AIRCRAFT CORP. CALIFORNIA DIVISION	Page	11
Checked	CL	TITLE	Fry a Brown Job.	Model	
Approved				20 pages	

Use 10,000 lb weight at 135,000

Try to eliminate finelage except for cockpit & engine. $W/D = 6.0$ to 6.5

Wing (Q. 1.32)	2,200
Tail (conventional)	200
Engine (2 Q. 20)	16,400
Wing (Q. 1.32)	400
Wing (Q. 1.32)	600
Wing (Q. 1.32)	200
Wing (Q. 1.32)	1,200
Wing (Q. 1.32)	1,500
Wing (Q. 1.32)	2,500
Wing (Q. 1.32)	300
Wing (Q. 1.32)	581
Wing (Q. 1.32)	1,000
Wing (Q. 1.32)	1,650
Wing (Q. 1.32)	500
Wing (Q. 1.32)	746
Wing (Q. 1.32)	300
Wing (Q. 1.32)	746

Wing load = 2,000 #

Range = $575 \times 6.0 \times 3.0$ / 2.10 = $10,000$ / $1,000$ = 1000 miles

APPROVED FOR RELEASE



Kelly Johnson's A-3 Design

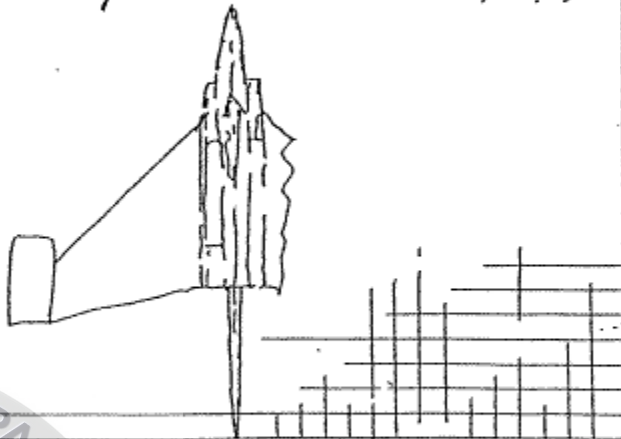
DATE	BY	REVISIONS	NO. OF SHEETS
Sept 29, 55	CLW	Design of A-3.	1

From previous work - a basic design of the following characteristics was derived (AAL trip - 3 page)

- Area - 500 sq
- Max wt. - 17,000 #
- Wt. at 100,000' - 13,200
- 2 - A.B. JT-12A
- 2 - 30" Ram jets.
- 300 # payload.
- M = 3.0 @ 100,000' (3.25)

Basic concept - reduce radar c.s.

Data given to SP on Thurs. - Sept. 25, '55



APPROVED FOR RELEASE

NEVADA AEROSPACE

HALL OF FAME

Although President Eisenhower supported the purchase of this type of aircraft, he questioned the plan to procure any before they had been tested. Promising that more thought would be given to the matter before such an order was placed, Secretary Quarles noted that CIA, the Defense Department, and the Bureau of the Budget were working on a funding plan for the project. The President suggested that the Air Force "could support the project by transferring some reconnaissance money." At the close of the meeting, Eisenhower asked the group to return after completing the next work phase to discuss further stages of the project with him.²

COMPETITION BETWEEN LOCKHEED AND CONVAIR

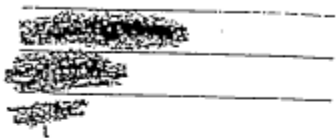
With funding for the proposed new type of aircraft now available, Richard Bissell asked Lockheed and Convair to submit detailed proposals. During the first half of 1959, both Lockheed and Convair worked to reduce the radar cross section of their designs, with assistance from ██████████. In pursuing his antiradar studies, ██████████ had discovered a phenomenon that he believed could be used to advantage by the new reconnaissance aircraft. Known as the Blip/Scan Ratio but also referred to as the ██████████, this phenomenon involved three elements: the strength of a radar return, the altitude of the object being illuminated by the radar, and the persistence of the radar return on the radar screen (Pulse-Position Indicator display).

Most tracking radars in the late 1950s swept a band of sky 30° to 45° wide and 360° in circumference. Any object encountered in this area reflected the radar pulse in a manner directly proportional to its size—the larger the object, the stronger the returning radar signal. This return appeared on the cathode-ray tube of the radar screen as a spot or blip, and the persistence of this blip on the radar screen also depended on the strength of the radar return, with blips from larger objects remaining on the screen longer. During the late 1950s and early 1960s, a human radar operator watched the radar screen and kept track of the blips that indicated aircraft within the radar's field of view.

² Andrew J. Goodpaster, "Memorandum of Conference with the President, 17 December 1958, 10:26 a.m.," 22 December 1958, WHOSS, Alpha, DDGL (TS).

APPROVED FOR RELEASE





~~_____~~ determined that a high-altitude object moving two to three times as fast as a normal aircraft would produce such a small blip with so little persistence that the radar operator would have great difficulty tracking it, if indeed he could even see it. ~~_____~~ estimated that for an aircraft to take advantage of this Blip/Scan Ratio phenomenon it must fly at altitudes approaching 90,000 feet and have a radar cross section of less than 10 square meters, preferably not much over 5 square meters. However, for a Mach 3.0 aircraft to achieve such a small radar cross section, its designers would have to make many concessions in its structural design and aerodynamics.*

By the summer of 1959, both firms had completed their proposals. In early June, Lockheed submitted a design for a ground-launched aircraft known as the A-11. It would have a speed of Mach 3.2, a range of 3,200 miles, an altitude of 90,000 feet, and a completion date of January 1961. Kelly Johnson had refused to reduce the aerodynamics of his design in order to achieve a greater antiradar capability, and the A-11's radar cross section, although not great, was substantially larger than that of the much smaller parasite aircraft being designed by Convair.*

The Convair proposal called for a small, manned, ramjet-powered, reconnaissance vehicle to be air launched from one of two specially configured Convair B-58B Super Hustlers. The FISH vehicle, a radical lifting body with a very-small-radar cross section, would fly at Mach 4.2 at 90,000 feet and have a range of 3,900 miles. Two Marquardt ramjets would power its Mach 4.2 dash over the target area. Once the FISH decelerated, two Pratt & Whitney JT-12 turbojets would bring it back to base. The ramjet exit nozzles and wing edges would be constructed of Pyroceram, a ceramic material that could withstand the high temperatures of very high speeds and would absorb radiofrequency energy from radar pulses. Convair stated that the FISH could be ready by January 1961.**

Convair's proposal depended on two uncertain factors. First and foremost was the unproven technology of ramjet engines. At the time, no aircraft in existence could carry a large, ramjet-powered craft into the sky and then accelerate to sufficient speed for the ramjet engines

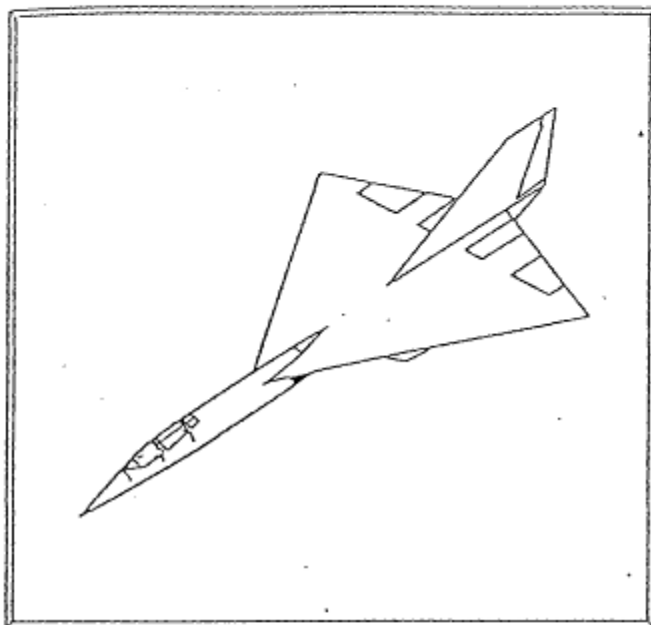
* Unnumbered Convair document on the Blip/Scan Ratio of ~~_____~~.

** Johnson, "Archangel log," December 1958-July 1959.

** OSA History, chap. 20, p. 12 ~~_____~~ Convair Division, General Dynamics Corporation, "Project FISH Status Review," 9 June 1959 (S).

APPROVED FOR RELEASE





Lockheed A-11

to be ignited. Since ramjet engines had only been tested in wind tunnels, there was no available data to prove that these engines would work in the application proposed by Convair. The second uncertain factor was the B-58B bomber that was supposed to achieve Mach 2.2 before launching the FISH above 35,000 feet. This version of the B-58 was still in the design stage.

Convair's proposal suffered a major setback in June 1959, when the Air Force canceled the B-58B project. Conversion of the older, slower B-58A into a supersonic launching platform for the FISH was ruled out by the high cost and technical difficulties involved. Moreover, the Air Force was unwilling to part with two aircraft from the small inventory of its most advanced bomber. Even had the B-58B program not been canceled, however, the FISH proposal would probably not have been feasible. Convair engineers had calculated that the added weight of the FISH would prevent the B-58B from achieving the speed required to ignite the parasite aircraft's ramjet engines.

The Convair proposal was therefore unusable, but the Lockheed design with its high radar cross section was also unacceptable to the Land committee. On 14 July 1959, the committee rejected both



~~_____~~
~~_____~~
~~_____~~

designs and continued the competition. Lockheed continued to work on developing a design that would be less vulnerable to detection, and Convair received a new CIA contract to design an air-breathing twin-engine aircraft that would meet the general specifications being followed by Lockheed."

Following recommendations by the Land committee, both Lockheed and Convair incorporated the Pratt & Whitney J58 power plant into their designs. This engine had originally been developed for the Navy's large, jet-powered flying boat, the Glenn L. Martin Company's P6M Seamaster, and was the most powerful engine available. In 1958 the Navy had canceled the Seamaster program, which had left Pratt & Whitney without a buyer for the powerful J58 engine."

Although the Land committee had not yet found an acceptable design, it informed President Eisenhower on 20 July 1959 that the search was making good progress. Concerned about the U-2's vulnerability to detection and possible interception and aware that the photosatellite project was encountering significant problems, the President gave his final approval to the high-speed reconnaissance aircraft project."

THE SELECTION OF THE LOCKHEED DESIGN

By the late summer of 1959, both Convair and Lockheed had completed new designs for a follow-on to the U-2. Convair's entry, known as the KINGFISH, used much of the technology developed for the F-102, F-106, and B-58, including stainless steel honeycomb skin, planiform wing design, and a crew capsule escape system, which eliminated the need for the pilot to wear a pressurized suit. The KINGFISH had two side-by-side J58 engines inside the fuselage, which significantly reduced the radar cross section. Two additional

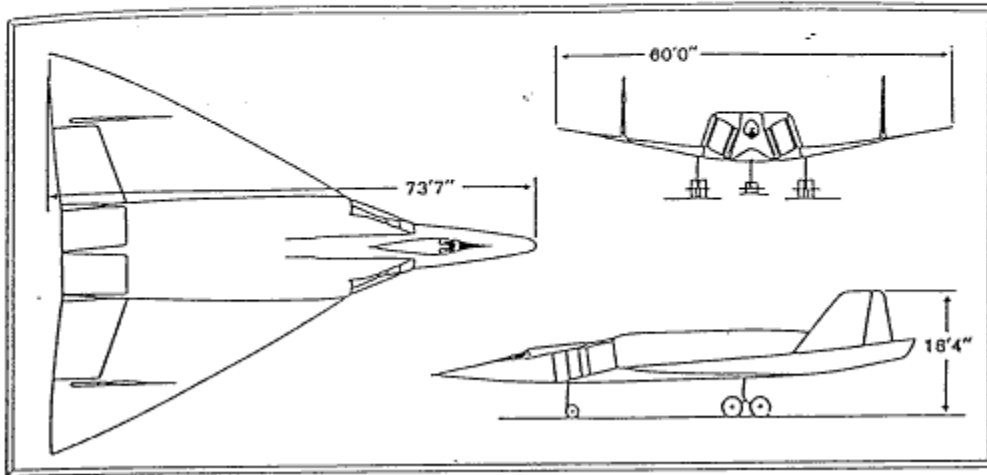
"OSA History, chap. 20, p. 15 ~~_____~~

"~~_____~~ interview, 4 October 1983 ~~_____~~ Joseph V. Charyk, interview by ~~_____~~ tape recording, Washington, DC, 5 December 1984 ~~_____~~

"Andrew J. Goodpaster, "Memorandum of Conference with the President," 20 July 1959, WHOSS, ALPHA, DDEL (TS).

APPROVED FOR RELEASE





important design features that contributed to a small radar return were fiberglass engine inlets and wings whose leading edges were made of Pyroceram.¹⁴

Convair KINGFISH

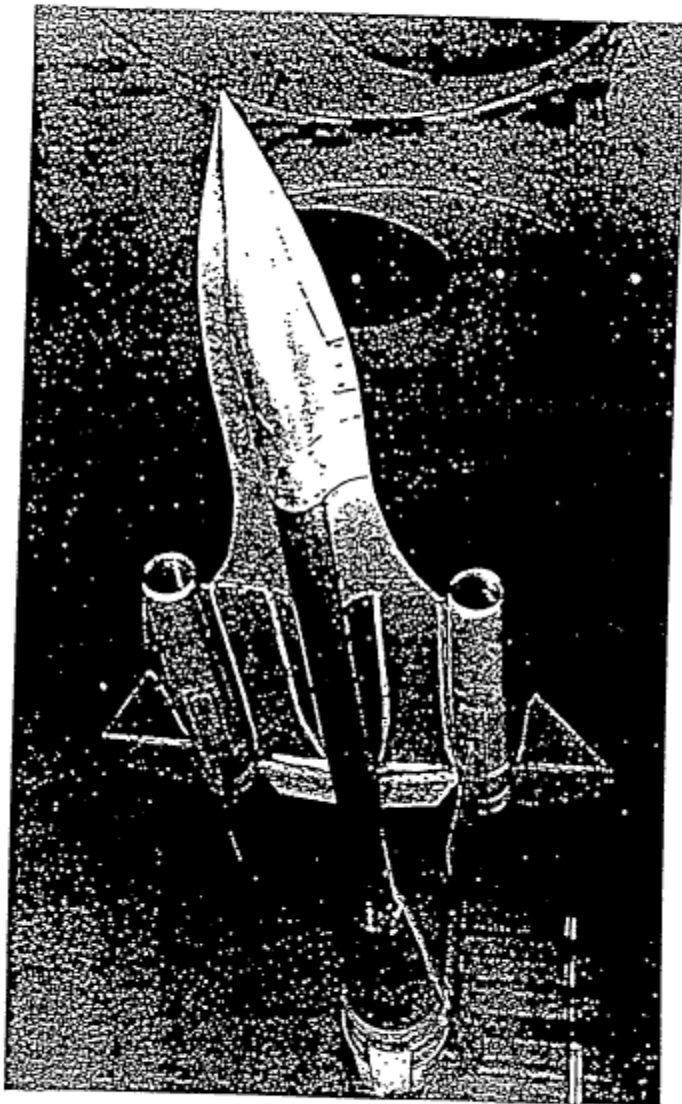
Lockheed's new entry was much like its first, but with several modifications and a new designator, A-12. It, too, would employ two of the powerful J58 engines. Lockheed's major innovation in reducing radar return was a cesium additive in the fuel, which decreased the radar cross section of the afterburner plume. This improvement had been proposed by Edward Purcell of the Land committee. Desiring to save weight, Kelly Johnson had decided not to construct the A-12 out of steel. Traditional lightweight metals such as aluminum were out of the question because they could not stand the heat that would be generated as the A-12 flew at Mach 3.2, so Johnson chose a titanium alloy.

On 20 August 1959, Lockheed and Convair submitted their proposals to a joint Department of Defense, Air Force, and CIA selection panel. As the table shows, the two aircraft were similar in performance

¹⁴Convair Division, General Dynamics Corporation, "KINGFISH Summary Report," 1959 (S). Kelly Johnson was very skeptical of the Convair design, noting in the Archangel project log on 1-20 August 1959: "Convair have promised substantially reduced radar cross section on an airplane the size of our A-12. They are doing this, in my view, with total disregard for aerodynamics, inlet and afterburner performance."

APPROVED FOR RELEASE





Wind tunnel test of A-12 model



APPROVED FOR RELEASE

characteristics, although the Lockheed design's specifications were slightly better in each category. The Lockheed design was also preferable in terms of overall cost. In the vital area of vulnerability to radar detection, however, the Convair design was superior. Its smaller size and internally mounted engines gave it a smaller radar cross section than the Lockheed A-12.¹⁵

Comparison of Lockheed and Convair Designs

	Lockheed A-12	Convair KINGFISH
Speed	Mach 3.2	Mach 3.2
Range (total)	4,120 nm	3,400 nm
Range (at altitude)	3,800 nm	3,400 nm
Cruising Altitude		
Start	84,500 ft.	85,000 ft.
Midrange	91,000 ft.	88,000 ft.
End	97,600 ft.	94,000 ft.
Cost summary (for 12 aircraft without engines)	\$96.6 million	\$121.6 million

Some of the CIA representatives initially favored the Convair KINGFISH design because of its smaller radar cross section, but they were eventually convinced to support the Lockheed design by the Air Force members of the panel, who believed that Convair's cost overruns and production delays on the B-58 project might be repeated in this new project. In contrast, Lockheed had produced the U-2 under budget and on time. Another factor favoring the A-12 was security. Lockheed had experience in running a highly secure facility (the Skunk Works) in which all of the key employees were already cleared by the Agency.

Despite its vote in favor of the Lockheed proposal, the selection panel remained concerned about the A-12's vulnerability to radar detection and therefore required Lockheed to prove its concept for reducing the A-12's radar cross section by 1 January 1960. On 14 September 1959, the CIA awarded a four-month contract to Lockheed

¹⁵ OSA History, chap. 20, pp. 18-19 (1963).



[REDACTED]

to proceed with antiradar studies, aerodynamic structural tests, and engineering designs. This research and all later work on the A-12 took place under a new codename, Project OXCART, established at the end of August 1959 to replace its more widely known predecessor, Project GUSTO.¹⁶ The CIA's project manager for OXCART was [REDACTED] who had long been associated with the U-2 program.

EFFORTS TO REDUCE THE A-12'S RADAR CROSS SECTION

During the spring of 1959, Kelly Johnson's Skunk Works crew—which then numbered only 50—had begun building a full-scale mockup of the proposed aircraft. The mockup was to be tested for its radar cross section by Edgerton, Germeshausen & Grier (EG&G) in cooperation with the [REDACTED]. Lockheed objected to this site because its pylon would not support the full-scale mockup and because the facilities were in full view of a nearby highway. On 10 September 1959, EG&G agreed to move its radar test facility [REDACTED].

When the new radar test facility with its larger pylon was ready, Johnson put the A-12 mockup on a specially designed trailer truck [REDACTED]. By 18 November 1959, the mockup was in place atop the pylon, and radar testing could begin. These tests soon proved that Lockheed's concept of shape, fuel additive, and nonmetallic parts was workable, but it would take more than 18 months of testing and adjustment before the OXCART achieved a satisfactory radar cross section.

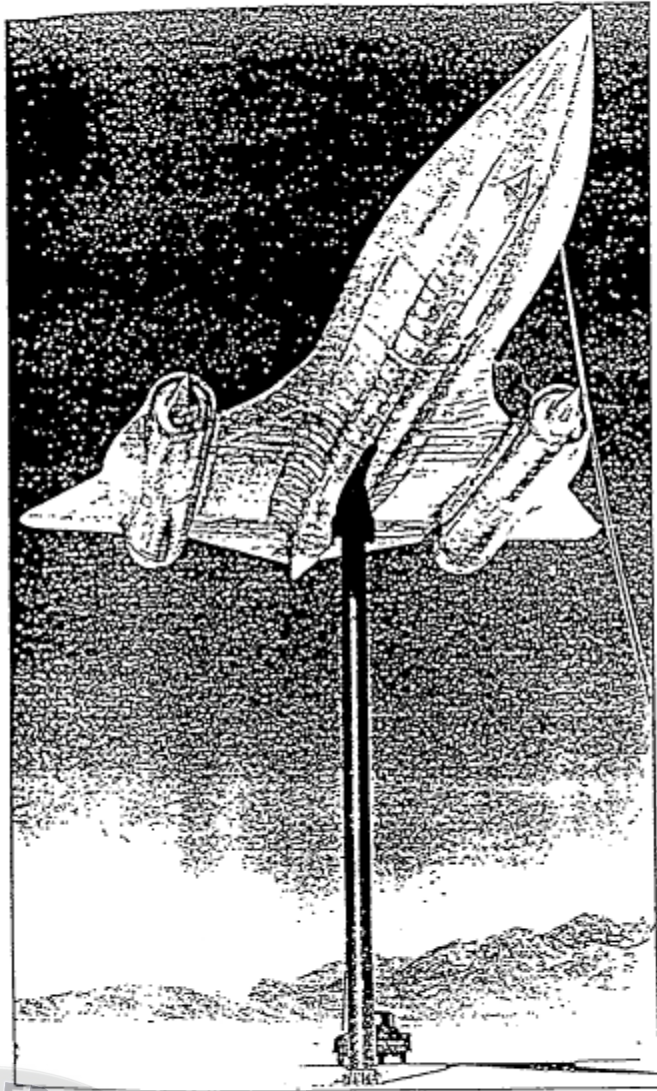
It was in the course of this radar testing that the OXCART received its characteristic cobra-like appearance. Edward Purcell and [REDACTED] had come up with a theory that a continuously curving airframe would be difficult to track with a radar pulse because it would present few corner reflectors or sharp angles from which pulses could bounce in the direction of the radar. To achieve the continuously curving airframe, Kelly Johnson added thin, curved extensions to the engine housings and leading edges of the wings and

¹⁶ [REDACTED] interview [REDACTED] OSA History, chap. 20, pp. 19-21 [REDACTED].

¹⁷ OSA History, chap. 20, p. 22 [REDACTED].

[REDACTED]

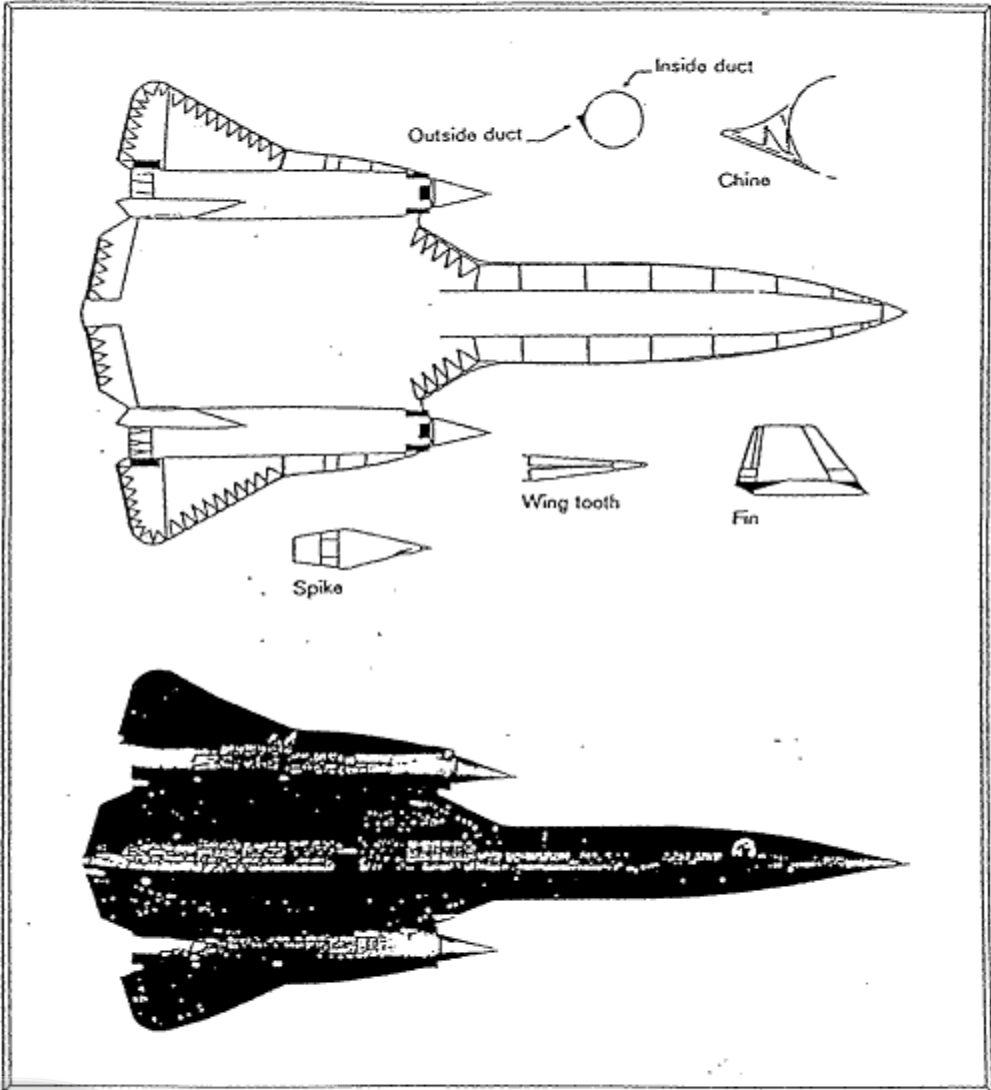




Radar testing of A-12 mockup



APPROVED FOR RELEASE



Antiradar features of the A-12

CLASSIFIED INFORMATION



eventually to the fuselage itself, creating what is known as a chine on each side. At first Johnson was concerned that these additions might impair the airworthiness of the plane, but wind tunnel testing determined that the chines actually imparted a useful aerodynamic lift to the vehicle. Because titanium was very brittle and therefore difficult to bend, Johnson achieved the necessary curvature by combining triangular-shaped pieces of titanium called fillets. These fillets were glued to the framework of the chines with a special adhesive, epoxy resin.

On later OXCART models the fillets were made from electrically resistive honeycomb plastic with a glass-fiber surface that would not melt at high speed. When struck by a radar pulse, the composite chines tended to absorb the pulse rather than reflect it. A similar approach was used for the leading edges of the wings. Again electrically resistive honeycomb material was fabricated into triangular shapes, known as wing teeth, and fitted into the titanium wings. Both the metal and composite fillets and teeth were held in place with the newly developed epoxy cements.

The greatest remaining area of concern in the A-12's radar cross section was the two vertical stabilizers. To reduce radar reflections, Kelly Johnson canted the stabilizers inward 15° and fabricated them out of resin-impregnated nonmetallic materials. Once these changes were completed, the only metal in each vertical stabilizer was a stainless steel pivot. The Air Force, which later ordered several versions of the OXCART aircraft for its own use, never adopted the laminated vertical stabilizers."

THE OXCART CONTRACT

By mid-January 1960, Lockheed had demonstrated that its concept of shape, fuel additive, and nonmetallic parts would reduce the OXCART's radar cross section substantially. Richard Bissell, however, was very upset to learn that the changes had led to a reduction in the aircraft's performance, which meant it would not be able to attain the penetration altitude he had promised to President Eisenhower. Kelly Johnson then proposed to reduce the aircraft's weight by 1,000 pounds and increase the fuel load by 2,000 pounds, making it possible

"Johnson, "Development of Lockheed SR-71," pp. 6-7; *OSA History*, chap. 20, p. 35

APPROVED FOR RELEASE





to achieve the desired target altitude of 91,000 feet. Afterward, he noted in the project log: "We have no performance margins left; so this project, instead of being 10 times as hard as anything we have done, is 12 times as hard. This matches the design number and is obviously right."¹⁴

These changes satisfied Bissell, who notified Johnson on 26 January that the CIA was authorizing the construction of 12 of the new aircraft. The actual contract was signed on 11 February 1960. Lockheed's original quotation for the project was \$96.6 million for 12 aircraft, but technological difficulties eventually made this price impossible to meet. Recognizing that fabricating an aircraft from titanium might involve unforeseen difficulties, the CIA included a clause in the contract that allowed costs to be reevaluated. During the next five years, this clause had to be invoked on a number of occasions as the A-12's costs soared to more than double the original estimate.¹⁵

NEW TECHNOLOGIES NECESSITATED BY OXCART'S HIGH SPEED

According to the specifications, the OXCART aircraft was to achieve a speed of Mach 3.2 (2,064 knots or 0.57 miles per second, which would make it as fast as a rifle bullet), have a range of 4,120 nautical miles, and reach altitudes of 84,500 to 97,600 feet. The new aircraft would thus be more than five times as fast as the U-2 and would go almost 3 miles higher.

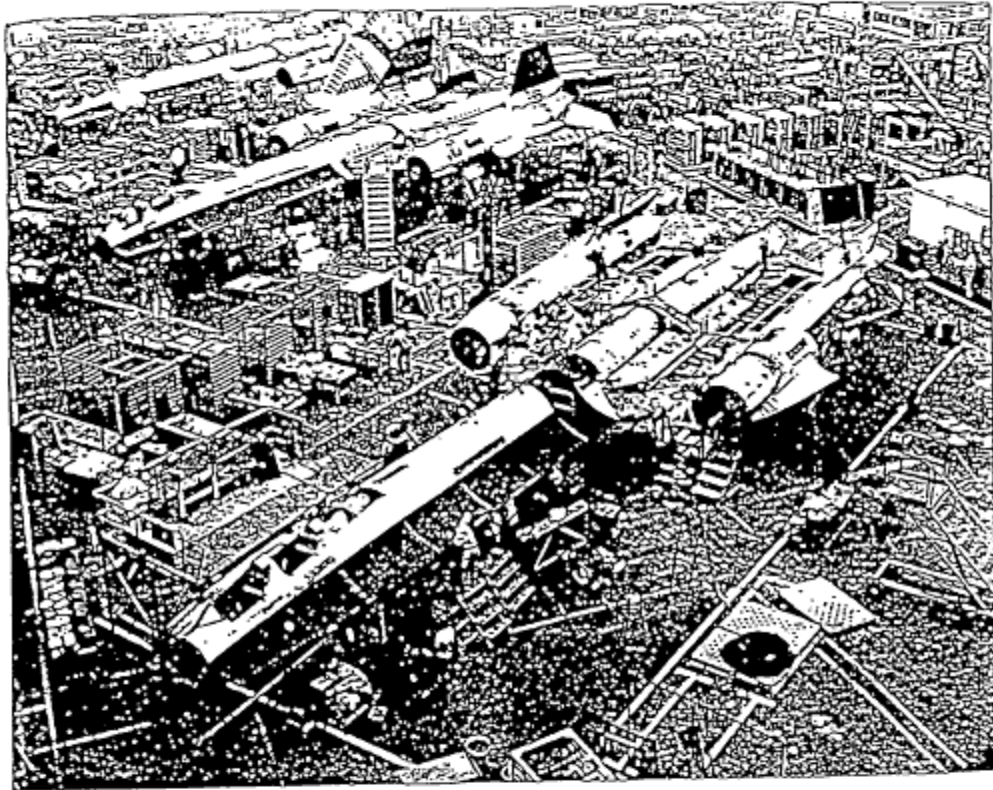
One major disadvantage of the OXCART's great speed was high temperatures. Flying through the earth's atmosphere at Mach 3.2 heated portions of the aircraft's skin to almost 900°F. An aircraft operating at these high speeds and high temperatures required fuels, lubricants, and hydraulic fluids that had not yet been invented. The OXCART's fuel requirement called for a low-vapor-pressure fuel with a low volume at operating temperatures; the fuel would also be used as a heat sink to cool various parts of the aircraft. The J58 engines required lubricants that did not break down at the very high operating temperatures of Mach 3.2 speeds. This requirement led to the

¹⁴ Johnson, "Archangel log," 21 January 1960.

¹⁵ OSA History, chap. 20, pp. 27-29, 33-34, 36 ~~FOUO~~

APPROVED FOR RELEASE





OXCART production facilities

invention of synthetic lubricants. Lockheed also had to search long and hard for a hydraulic fluid that would not vaporize at high speed but would still be usable at low altitudes. Finding a suitable hydraulic pump was just as difficult. Kelly Johnson finally modified a pump that was being developed for North American's B-70 bomber project.²¹

Some of the greatest problems related to the high speeds and high temperatures at which the OXCART operated resulted from working with the material chosen for the airframe—titanium. After evaluating many materials, Johnson had chosen an alloy of titanium

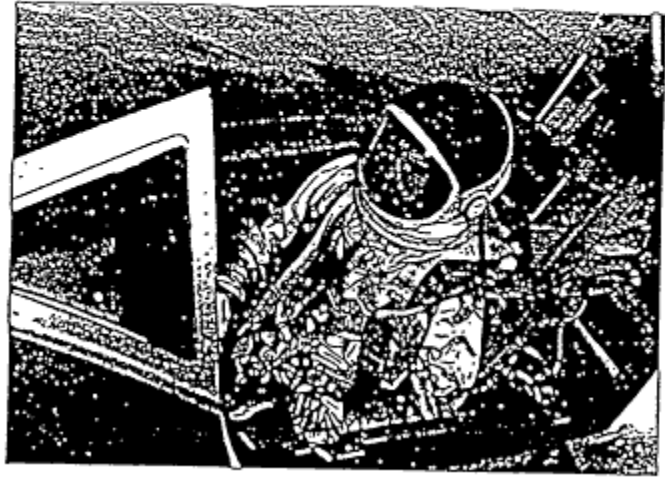
²¹ Johnson, "Development of Lockheed SR-71," pp. 11-12.

APPROVED FOR RELEASE



[REDACTED]

OX CART pilot suit



(B-120) characterized by great strength, relatively light weight, and good resistance to high temperatures, but high in cost. As strong as stainless steel, titanium weighed slightly more than half as much. Obtaining sufficient quantities of titanium of a quality suitable for fabricating aircraft components proved very difficult because methods for maintaining good quality control during the milling of titanium were not fully developed. Up to 80 percent of the early deliveries from Titanium Metals Corporation had to be rejected. It was not until 1961, when company officials were informed of the objectives and high priority of the OXCART program, that problems with the titanium supply ended. Even after sufficient high-quality titanium was received, Lockheed's difficulties with the metal were not over. Titanium was so hard that tools normally used in aircraft fabrication broke; new ones therefore had to be devised. Assembly line production was not possible, and the cost of the program mounted well above original estimates."

The high temperatures that the OXCART would encounter also necessitated planning for the pilot's safety and comfort because the inside of the aircraft would be like a moderately hot oven. To save

[REDACTED] "OX CART Story," p. 59; OSA History, chap. 20, p. 33 [REDACTED]

APPROVED FOR RELEASE



weight, Kelly Johnson did not attempt to insulate the interior of the aircraft. The pilot would therefore have to wear a type of space suit with its own cooling, pressure control, oxygen supply, and other necessities for survival.

DESIGNING THE OXCART'S CAMERAS

Providing cameras for the A-12 posed a number of unique problems. In late 1959, OXCART managers asked Perkin-Elmer, [REDACTED] and Hycon to develop three different photographic systems for the new aircraft. These cameras would provide a range of photography from high-ground-resolution stereo to extremely-high-resolution spotting data.

The Perkin-Elmer (P-E) entry, known as the Type-I camera, was a high-ground-resolution general stereo camera using an f/4.0 18-inch lens and 6.6-inch film. It produced pairs of photographs covering a swath 71 miles wide with an approximately 30-percent stereo overlap. The system had a 5,000-foot film supply and was able to resolve 140 lines per millimeter and provide a ground resolution of 12 inches.

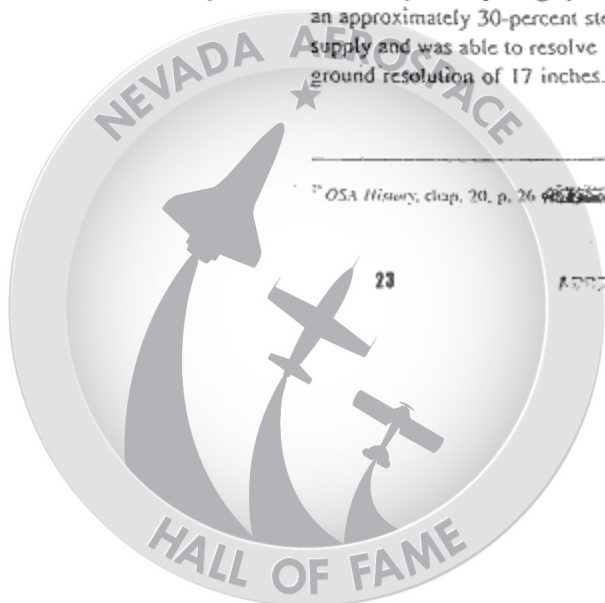
To meet severe design constraints in the areas of size, weight, thermal environment, desired photographic resolution, and coverage, Perkin Elmer's Dr. Roderick M. Scott employed concepts never before used in camera systems. These included the use of a reflecting cube rather than a prism for the scanner, a concentric film supply and takeup system to minimize weight shift, a constant-velocity film transport that provided for the contiguous placement of stereo images on one piece of film, and airbars for the film transport and takeup systems.²³

[REDACTED] entry, called the Type-II camera, was a high-convergent stereo device using a 21-inch lens and 8-inch film. It produced pairs of photographs covering a swath 60 miles wide with an approximately 30-percent stereo overlap. It had an 8,400-foot film supply and was able to resolve 105 lines per millimeter and provide a ground resolution of 17 inches.

²³ OSA History, chap. 20, p. 26 [REDACTED] "OXCART Story," p. 4 (5).

FOIA(b)(1)
E012356
§ 1.3 (a)(4)
FOIA(b)(3)
50 USC 403-3(c)(5)

87-23



[REDACTED]

The Hycon entry, designed by James Baker and known as the Type-IV camera, was a spotting camera with extremely-high-ground resolution. In fact, it was an advanced version of the highly reliable B camera developed for the original U-2 program. It used a 48-inch Baker-designed $f/5.6$ lens to focus images onto 9.5-inch film. Like the B camera it could provide seven frames of photography covering a swath 41 miles wide with stereo overlap on 19 miles of the swath. The Hycon camera carried the largest film supply of the three cameras, 12,000 feet. It was able to resolve 100 lines per millimeter and provide a ground resolution of 8 inches. A version of this 48-inch Hycon camera, known as the H camera, later saw service in U-2R aircraft.

Each of the three camera systems had unique capabilities and advantages, so all three were purchased for the OXCART. Before they could be effectively employed in the aircraft, however, new types of camera windows were needed. The OXCART's camera windows had to be completely free from optical distortion. Achieving this goal was difficult in a window whose exterior would be subjected to temperatures of 550°F while the interior surface would be only 150°F. After three years and the expenditure of \$2 million in research and development, the Corning Glass Works, which had joined this effort as a Perkin-Elmer subcontractor, solved the problem of producing a camera window that could withstand tremendous heat differentials. Its quartz glass window was fused to the metal frame by an unprecedented process involving high-frequency sound waves.²¹

Later in the program, the OXCART received yet another camera system. In 1964 the Texas Instruments Corporation developed an infrared camera for Project TACKLE U-2s that were being used to determine whether the [REDACTED]. This stereo device, known as the FFD-4, was adapted for use in OXCART. The camera had an effective focal length of 50 inches and a 150-foot supply of 3.5-inch film. The camera's resolution was 3°C thermally, 1-milliradian spatially, and 60 feet on the ground. It could be used for both day and night imagery collection.

²¹ Baker interview [REDACTED] "OXCART Story," pp. 5-6(45).

APPROVED FOR RELEASE



[REDACTED]

CHOOSING PILOTS FOR OXCART

Just as in the U-2 program, the Air Force provided considerable support to Project OXCART, including training, fuel storage, and weather service. One of the most important areas of support was the provision of pilots; all of the OXCART pilots came from the Air Force. Prospective pilots had to be qualified in the most advanced fighters and be emotionally stable and well motivated.

[REDACTED]

[REDACTED]

[REDACTED] Because of the limited size of the A-12 cockpit, they had to be under six feet tall and weigh less than 175 pounds. Following extensive physical and psychological screening, 16 potential nominees were selected for intensive security and medical screening by the Agency. By the end of this screening in November 1961, only five individuals had been approved and had accepted the Agency's offer of employment on a highly classified project involving a very advanced aircraft. A second search and screening raised the number of pilots for the OXCART to eleven. The thorough screening process produced an elite group of pilots; all but one of these 11 officers eventually became generals.

[REDACTED]

[REDACTED]

FOIA (b)(1)
EO 12356
§ 1.3 (a) (4)
FOIA (b)(3)
50 USC 403-3
(c)(5)

SELECTION OF A TESTING SITE FOR THE OXCART

From the very beginning, it was clear that Lockheed could not test the OXCART aircraft at its Burbank facility, where the runway was too short and too exposed to the public. The ideal testing site would be far removed from metropolitan areas, away from civil and military airways, easily accessible by air, blessed with good weather, capable of accommodating large numbers of personnel, near an Air Force installation, and having a runway at least 8,000 feet long. But no such place was to be found.

After considering 10 Air Force bases programmed for closing, Richard Bissell decided to [REDACTED] the [REDACTED]. Although its personnel accommodations, fuel

"OXCART Story," pp. 6-7. OSA History, Chap. 20, pp. 48-50
[REDACTED] Gary interview with Pedlow

p. 25

APPROVED FOR RELEASE





storage capacity, and runway length were insufficient for the OXCART program, the site's remote location would greatly ease the task of maintaining the program's security, and a moderate construction program could provide adequate facilities. Construction began in September 1960; a C-47 shuttle service ferried work crews from Burbank to Las Vegas and from Las Vegas to the site.

The new 8,500-foot runway was completed by 15 November 1960. Kelly Johnson had been reluctant to have a standard Air Force runway with expansion joints every 25 feet because he feared the joints would set up undesirable vibrations in the speedy aircraft. At his suggestion a 150-foot wide runway was therefore constructed of six 25-foot-wide longitudinal sections, each 150 feet long but staggered. This layout put most of the expansion joints parallel to the direction of aircraft roll and reduced the frequency of the joints.

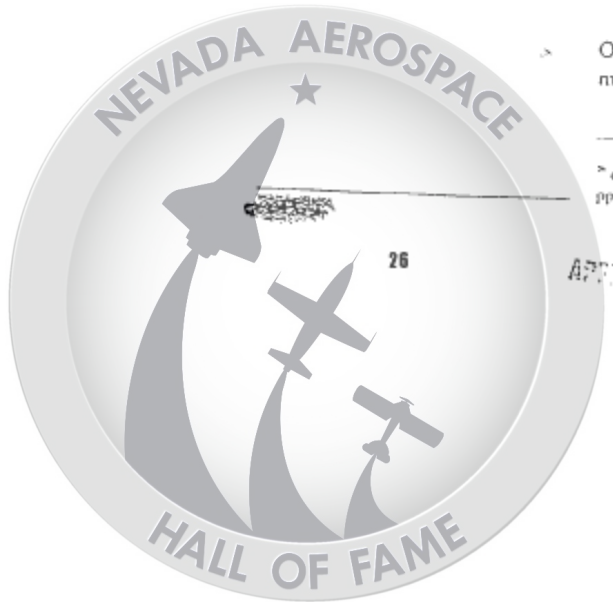
Additional improvements included the resurfacing of 18 miles of highway leading to the base so that heavy fuel trucks could bring in the necessary fuel. The need for additional buildings on the base was met by the Navy. Three surplus Navy hangars were dismantled, moved, and reassembled on the north side of the base, and more than 100 surplus Navy housing buildings were also transported to ~~the base~~. All essential facilities were ready in time for the forecast delivery date of the first A-12 on 1 August 1961.²⁶

Unfortunately, this delivery date began to slip further and further into the future. Delays in obtaining the titanium, and later the J58 engines, caused the postponement of the final assembly of the first plane. Eventually, Kelly Johnson and Agency project officials decided to begin testing without waiting for the J58 engines by using Pratt & Whitney J75/19W engines, designed for the Convair F-106, to test the A-12 at altitudes up to 50,000 feet and at speeds up to Mach 1.6. Such a change, however, meant that the engine compartment of the first aircraft had to be reconfigured to accommodate the J75 engine. Lockheed hoped that this substitution would permit the delivery of the first A-12 by 22 December 1961 and its initial test flight by 27 February 1962.

Lockheed ran into so many technological problems with the OXCART effort that by October 1961 its costs had swollen to \$136 million and were still climbing. Something obviously had to be done

²⁶ OSA History, chap. 20, pp. 39-40, 43, 51. ~~See also Kelly Johnson, "OXCART Story," pp. 7-9 (5).~~

APPROVED FOR OPI - -



to reduce expenditures. After much refiguring, project officials decided to decrease the number of deliverable aircraft. Amendment No. 11 to the contract reduced from 12 to 10 the number of A-12s, for a total cost of \$161.2 million.²⁷

The cancellation of these two A-12s was offset by an Air Force order for the development of a supersonic interceptor variant of the A-12 to serve as a replacement for the North American F-108A Rapier interceptor project, which had been canceled in late 1960. With the assistance of the ~~United States Air Force~~, the Air Force entered into an agreement with Lockheed to produce three AF-12 aircraft, based on the A-12 design but modified to carry a second crewman and three air-to-air missiles. This effort was called Project KEDLOCK. The AF-12 (later redesignated the YF-12A) was designed to intercept enemy bombers long before they reached the United States, and initial Air Force plans envisioned a force of up to 100 of these supersonic interceptors. In fact, only three of these planes were built and delivered during the 1963-64 time frame because Secretary of Defense McNamara canceled the program as a cost-cutting measure. The Air Force bore all of the costs of the YF-12A project; CIA was only involved in helping to write "black" contracts.²⁸

Lockheed was not the only OXCART contractor having trouble containing costs; Pratt & Whitney was fighting an even bigger battle. In mid-1961, Pratt & Whitney overruns threatened to halt the entire OXCART project. At the suggestion of Cdr. William Holcomb in the office of the Chief of Naval Materiel, Richard Bissell asked the Navy to assist in funding the J58's development. After hearing Bissell and Holcomb's suggestion that the J58 might be used in future Navy aircraft, VAdm. William A. Schoech, Chief of the Navy Materiel Command that had originally financed the J58 engine, authorized the transfer of \$38 million in end-of-year funds to the project, thus keeping the OXCART's head above water.²⁹ As it turned out, the J58 was never used in a Navy aircraft.

²⁷ OSA History, chap. 20, pp. 46-47, 51-55 (redacted), "OXCART Story," p. 10.

²⁸ OSA History, chap. 20, pp. 46-47 (redacted).

²⁹ ~~Interview~~ OSA History, chap. 20, p. 55 (redacted)—During this period, Kelly Johnson was very disappointed with Pratt & Whitney's work on the J58, particularly when they shocked him in September 1961 with the news that the engine would be overweight, underpowered, and late. Johnson, "Archangel log," 11 September 1961.





DELIVERY OF THE FIRST OXCART

The first A-12, known as article 121, was assembled and tested at Burbank during January and February 1962. Since it could not be flown to the ~~site~~, the aircraft had to be partially disassembled and put on a specially designed trailer that cost nearly \$100,000. The entire fuselage, without the wings, was crated and covered, creating a load 35 feet wide and 105 feet long. To transport this huge load safely over the hundreds of miles to the site, obstructing road signs were removed, trees were trimmed, and some roadbanks had to be leveled. The plane left Burbank on 26 February 1962 and arrived at ~~the site~~ two days later.

After the fuselage arrived in ~~the site~~, its wings were attached and the J75 engines were installed, but the aircraft was still not ready to be tested. This new delay was caused by leaking fuel tanks, a problem that would never be solved completely. Because the A-12's high speeds heat the titanium airframe to more than 500°F, Lockheed designers had to make allowances for expansion. When the metal was cold, the expansion joints were at their widest. In the fuel tanks, these gaps were filled by pliable sealants, but the fuel for the A-12's engines acted as a strong reducing agent that softened the sealants, causing leaks. Thus, when fuel was first poured into the aircraft, 68 leaks developed. Lockheed technicians then stripped and replaced all the sealant, a tedious and time consuming procedure because the sealant required four curing cycles, each at a different temperature over a period of 30 to 54 hours. The engineers were never able to discover a sealant compound that was completely impervious to the jet fuel while remaining elastic enough to expand and contract sufficiently. The A-12's tanks continued to leak, so when it was fueled, it only received enough fuel to get airborne. The plane would then rendezvous with a tanker, top off its tanks, and immediately climb to operating altitude, causing the metal to expand and the leaks to stop."

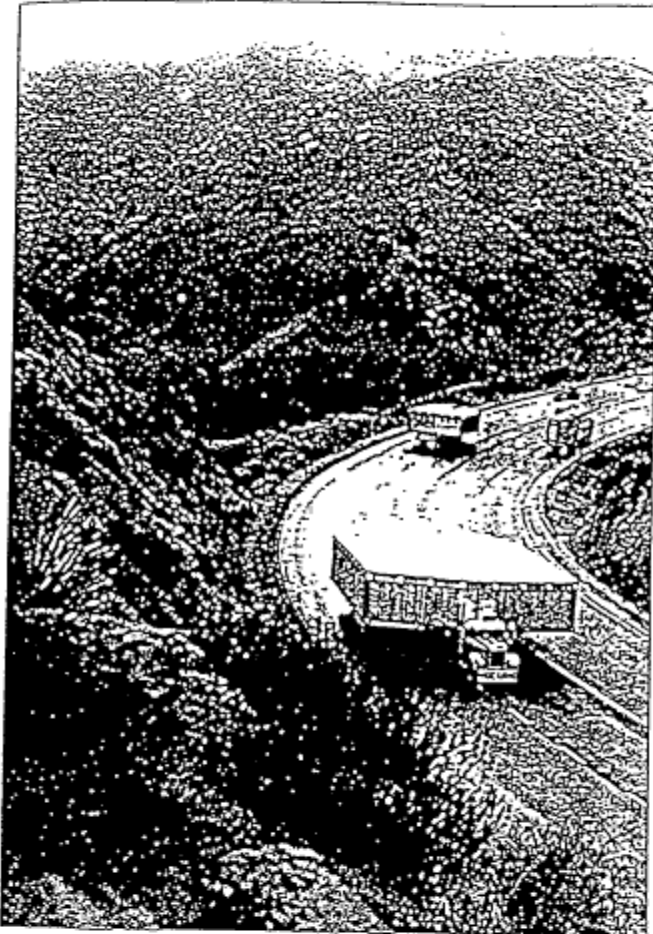
CHANGES IN THE PROJECT MANAGEMENT

Richard Bissell, whose concern for the viability of the U-2 in 1956 had led to the establishment of Project OXCART and who had directed its growth all along, was no longer in charge when the first

¹ OSA History, chap. 20, p. 62 (~~the OXCART Story~~ "OXCART Story," p. 14)

APPROVED FOR RELEASE

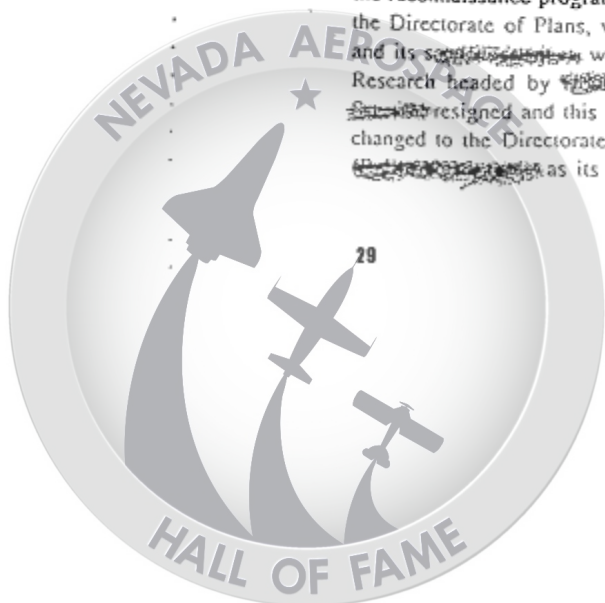


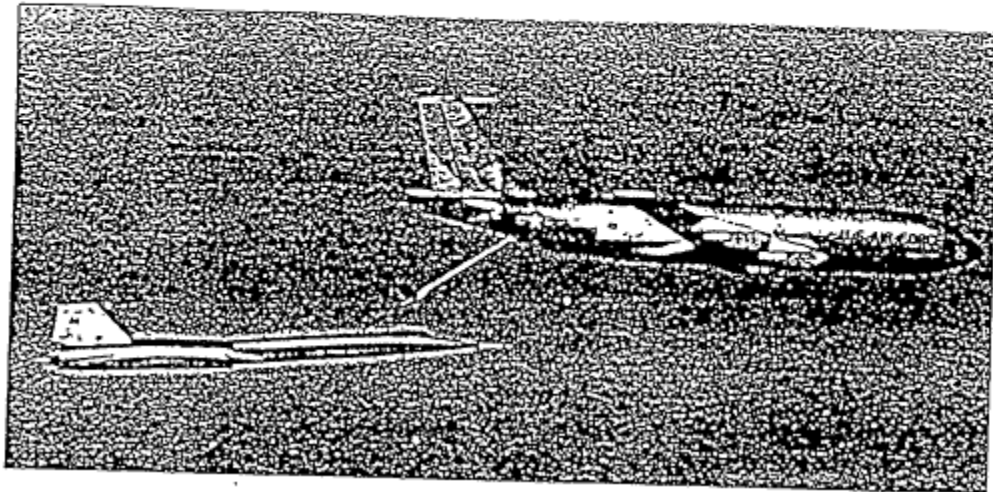


Delivery of OXCART aircraft to

OXCART aircraft took to the air. He resigned from the Agency in February 1962, and his departure brought a major reorganization of the reconnaissance program. The Development Projects Division of the Directorate of Plans, with its two aircraft (OXCART and U-2) and its support facilities were transferred to the new Directorate of Research headed by [REDACTED]. The following year [REDACTED] resigned and this Directorate was reorganized and its name changed to the Directorate of Science and Technology, with [REDACTED] as its first head. The overhead reconnaissance

APPROVED FOR RELEASE





In-flight refueling of the OXCART

projects belonged to the Office of Special Activities, headed by [redacted] who now had the title of Assistant Director for Special Activities. These project management changes in the CIA had no immediate impact on the OXCART project because the aircraft was still in the development stage, handled mainly by the contractors. Moreover, a good deal of continuity was provided by officers who had served for a number of years with the U-2 program and were now involved with OXCART: [redacted] the Deputy Assistant Director for Special Activities; [redacted] the Air Force's project officer for the two aircraft; and [redacted] who oversaw the day-to-day affairs of the OXCART project.

OXCART'S FIRST FLIGHTS

With new sealant in its fuel tanks, the prototype OXCART was ready to take to the air. On 25 April 1962, test pilot Louis Schalk took "article 121" for an unofficial, unannounced flight, which was an old Lockheed tradition. He flew the craft less than two miles at an altitude of about 20 feet and encountered considerable problems because of the improper hookup of several controls. These were promptly repaired and on the next day, 26 April, Schalk made the official 40-minute maiden flight. After a beautiful takeoff, the aircraft began shedding the triangular fillets that covered the framework of the chines along the edge of the aircraft body. The lost

APPROVED FOR RELEASE



fillets, which had been secured to the airframe with epoxy resin, had to be recovered and reattached to the aircraft, a process that took the next four days.

Once the fillets were in place, the OXCART's official first flight took place on 30 April 1962, witnessed by a number of Agency personnel including DDR [redacted] was also present, and Kelly Johnson noted in the project log, "I was very happy to have Dick see this flight, with all that he has contributed to the program."³¹ This official first flight was also the first flight with the wheels up. Piloted again by Schalk, the OXCART took off at 170 knots and climbed to 30,000 feet. During the 59-minute flight, the A-12 achieved a top speed of 340 knots. Kelly Johnson declared it to be the smoothest first test flight of any aircraft he had designed or tested. On 2 May 1962, during the second test flight, the OXCART broke the sound barrier, achieving a speed of Mach 1.1.³²

Four more aircraft, including a two-seat trainer, arrived at the testing site before the end of the year. During the second delivery on 26 June 1962, the extra-wide vehicle carrying the aircraft accidentally struck a Greyhound bus traveling in the opposite direction. Project managers quickly authorized payment of \$4,890 for the damage done to the bus in order to avoid having to explain in court why the OXCART delivery vehicle was so wide.

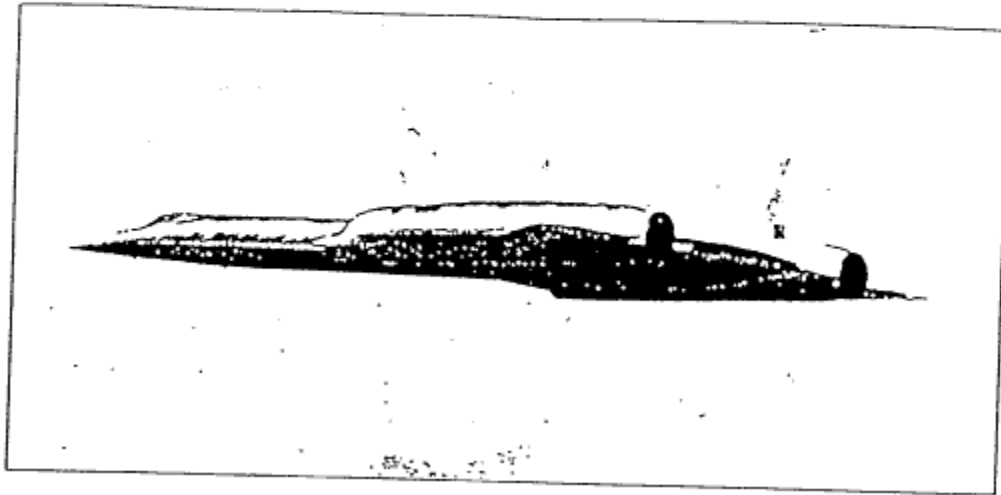
One of the biggest problems connected with flight testing the A-12 was keeping its existence secret. Realizing that the nation's air traffic controllers would be among the first unwitting people to learn about the plane, the Deputy Assistant Director for Special Activities, [redacted] had called on Federal Aviation Administrator [redacted] in early 1962 to brief him about the craft's existence and ask his assistance in keeping it secret. [redacted] cooperated fully with the Agency and personally briefed all FAA regional chiefs on how to handle reports of unusually fast, high-flying aircraft. Air controllers were warned not to mention the craft on the radio but to submit written reports of sightings or radar trackings. The Air Force gave similar briefings to NORAD, the North American Air Defense Command.³³

³¹ Johnson, "Archangel log," 30 April 1962.

³² OSA History, chap. 20, p. 63; [redacted], "OXCART Story," pp. 11-12.

³³ [redacted], "OXCART Story," pp. 10-11; OSA History, chap. 20, p. 60.





First flight of the A-12,
30 April 1962

Initial testing could not explore the A-12's maximum potential, since the J58 engine was still not ready. Developing this power plant to OXCART specifications was proving much more difficult than had been expected because the J58 had to reach performance levels never before achieved by a jet engine, while operating under extremely difficult environmental conditions. To simulate the stress that the J58 would undergo during maximum power output (Mach 3.2 at 97,000 feet), the power plant was tested in the exhaust stream of a J75 engine. In the course of this extremely severe testing, the J58's problems were gradually overcome. By January 1963, Pratt & Whitney had delivered 10 J58 engines to the ~~test~~ testing site. The first flight of an A-12 with two J58 engines took place on 15 January 1963.²⁶

SPEED-RELATED PROBLEMS

As J58-equipped A-12s reached higher and higher speeds, more difficulties arose. Major problems developed at speeds between Mach 2.4 and 2.8 because the aircraft's shock wave interfered with the flow of air into the engine, greatly reducing its performance. Solving this problem required long and often highly frustrating experimentation

²⁶ ~~Source:~~ ~~OSI~~ "J58/SR-71 Propulsion Integration," *Studies in Intelligence* 26 (Summer 1982): pp. 17-18 (U); *OSA History*, chap. 20, pp. 58, ~~60-61~~.

APPROVED FOR RELEASE



[REDACTED]

that ultimately required a complete redesign of the air-inlet system that controlled the amount of air admitted to the engine. In the new, adjustable inlet the cone-shaped projection at the front—known as a spike—was designed to move in or out as much as three feet in order to capture and contain the shock wave produced by the aircraft at high speeds, thus preventing the shock wave from blowing out the fire inside the engine.”

Another J58 engine problem in early 1963 was foreign object damage. Small objects such as pens, pencils, screws, bolts, nuts, and metal shavings that fell into the engine nacelles during assembly at Burbank were sucked into the power plant during initial engine testing at [REDACTED] and damaged impeller and compressor vanes. To control the problem Lockheed instituted a program that included X-rays, shaking of the nacelles, installing screens over various air inlets to the engine, and even having workers wear coveralls without breast pockets. Another source of foreign object damage was trash on the runways. The giant J58 engines acted like immense vacuum cleaners, sucking in anything lying loose on the paving as they propelled the A-12 down the runway for takeoff. To prevent engine damage, [REDACTED] personnel had to sweep and vacuum the runway before aircraft takeoff.”

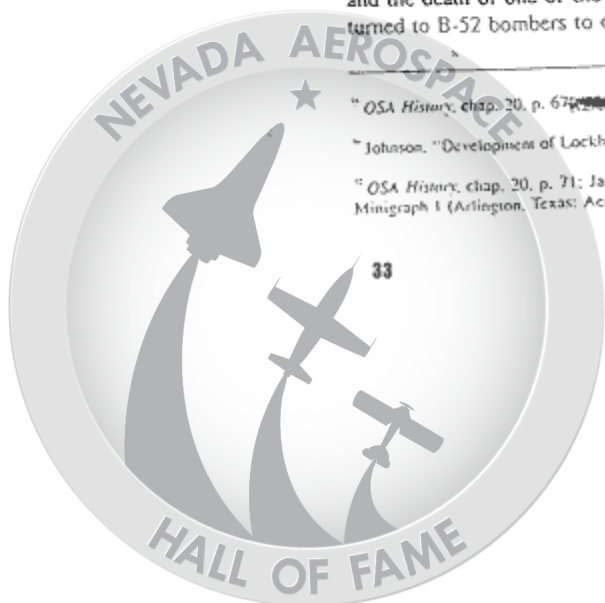
NEW VERSIONS OF THE OXCART

In 1962 the Agency and the Air Force ordered two more versions of the OXCART (in addition to the A-12 and the YF-12A). One was a modification of the A-12 to carry and launch ramjet-powered, 43-foot-long drones capable of reaching Mach 3.3. The two-seater mothership received the designation M-12; the drone was called the D-21. This project was known as TAGBOARD. The original development of the drones and mothership was sponsored by the CIA, but in June 1963 the project was turned over to the Air Force, which had overall responsibility for unmanned reconnaissance aircraft. Development of the M-12/D-21 combination continued until 1966, when an unsuccessful D-21 launch caused the loss of its mothership and the death of one of the crew members. Afterward the Air Force turned to B-52 bombers to carry the drones.”

“OSA History, chap. 20, p. 67.”

“Johnson, “Development of Lockheed SR-71,” p. 12.

“OSA History, chap. 20, p. 71; Jay Miller, *Lockheed SR-71 (A12/YF12/D-21)*. Acrofax Mintage 1 (Arlington, Texas: Acrofax, Inc., 1985), p. 3.



[REDACTED]

The second new version of the OXCART was another reconnaissance aircraft. In December 1962 the Air Force ordered six "reconnaissance/strike" aircraft, which were designed to conduct high-speed, high-altitude reconnaissance of enemy territory after a nuclear strike. This new aircraft differed from other A-12 versions in that it was longer, had a full-blown two-seat cockpit, and carried a large variety of photographic and electronic sensors. The additional weight of all this equipment gave the Air Force craft a slower maximum speed and a lower operating ceiling than the Agency's A-12. In August 1963, the Air Force added 25 more aircraft to this contract, for a total of 31.³⁴

**THE QUESTION OF SURFACING
A VERSION OF THE OXCART**

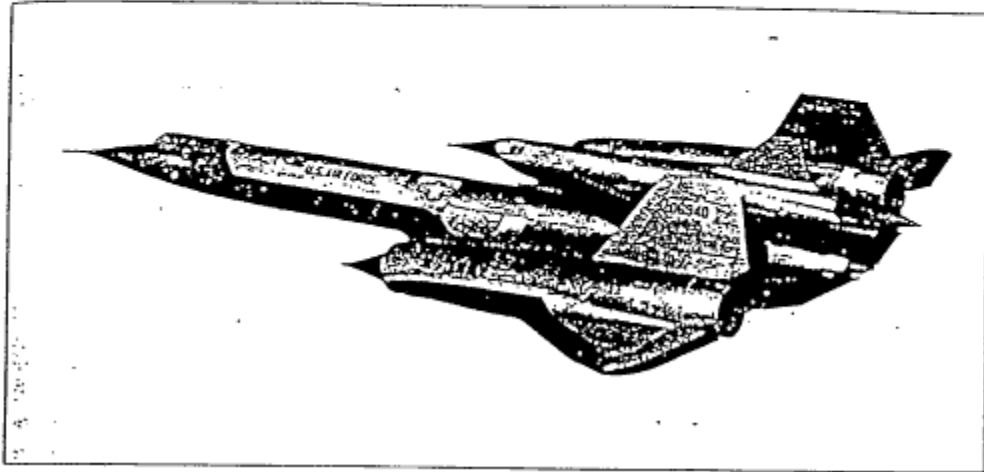
As the funds being spent on Air Force versions of the OXCART increased dramatically, the Defense Department became concerned that it could not offer any public explanation for these expenditures. At the same time, Agency and Defense Department officials recognized the growing danger that a crash or sightings of test flights could compromise the program. This led the Defense Department in late 1962 and early 1963 to consider surfacing the Air Force's interceptor version of the A-12 to provide a cover for OXCART sightings or crashes and an explanation for the rise in Air Force spending. Some journalists had also become aware of the aircraft's existence, raising concern that the secret would eventually come out in the press. Agency officials remained reluctant to reveal the existence of any version of the A-12, and the issue soon came to the attention of the PFIAB. James Killian and Edwin Land strongly opposed disclosing OXCART's existence, and in January 1963 they presented their views to President Kennedy at a meeting attended by DCI McCone and Defense Secretary Robert McNamara. Killian, Land, and McCone succeeded in persuading the President and Secretary of Defense to keep the OXCART's existence a secret for the time being.

Later that year supporters of the idea of surfacing the OXCART found a more powerful argument for their proposal—the need to disseminate the supersonic technology that had been developed for the

³⁴ OSA History, chap. 20, pp. 71-72 [REDACTED]

Approved for Release





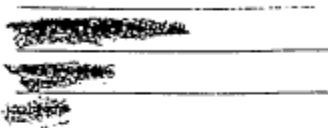
M-12 carrying D-21 Drone

OX CART. This technology would be invaluable for Air Force projects such as the B-70 bomber and for the civilian supersonic transport (SST) then being discussed in Congress. In the fall of 1963, several Presidential advisers expressed their concern to DCI McCone that Lockheed had received a \$700 million headstart in the development of supersonic technology, giving the firm a tremendous advantage over other aerospace companies working on a supersonic transport. McCone passed these concerns on to President Kennedy on 12 November 1963, just 10 days before the fateful trip to Dallas. The President instructed CIA and the Defense Department to develop a plan for surfacing the OXCART but to await further discussions with him before taking any action.³⁹

President Lyndon B. Johnson received a detailed briefing on the OXCART program from McCone, McNamara, Bundy, and Rusk on 29 November, after just one week in office. McNamara strongly advocated surfacing a version of the OXCART. McCone was more cautious, calling for the preparation of a statement that could be used when surfacing became necessary but arguing that such a step was not

³⁹ John A. McCone, "Memorandum of Meeting in Cabinet Room for the Purpose of Discussing the Surfacing of the OX," 21 January 1963, DCI records (114-55000); idem, Memorandum for the Record, Discussion with the President—October 21st—6:00 p.m., 22 October 1963, DCI records (114-55000); OSA History, chap. 20, pp. 73-74.





yet needed. Agreeing with McCone's position, President Johnson said the issue should be reviewed again in February.³⁴

One additional argument in favor of surfacing the OXCART was the realization that the aircraft could not be used to fly undetected over the Soviet Union. By 1962 the United States had become aware of the effectiveness of a new Soviet radar system, codenamed TALL KING. The introduction of this computer-controlled radar undercut one of the basic premises of the OXCART program, the assumption that radar operators would not be able to track high-flying supersonic targets visually because of their small, nonpersistent radar returns. By coupling a computer to a radar, the Soviets could now weight the individual radar returns and identify those produced by high-flying, very fast objects.⁴¹

By February 1964 DCI McCone had become convinced that surfacing was necessary. Soviet development of the TALL KING radar system had eliminated his hope that OXCART would eventually be able to carry out its original intended purpose—overflights of the USSR. The final decision on the issue of surfacing the OXCART came at a National Security Council meeting on 29 February 1964, at which all of the participants supported the decision to surface. That same day President Johnson held a news conference at which he announced the successful development of an "advanced experimental jet aircraft, the A-11, which has been tested in sustained flight at more than 2,000 miles per hour and at altitudes in excess of 70,000 feet."⁴²

President Johnson had spoken of the A-11 rather than the Agency's A-12, and the aircraft that was actually revealed to the public was the Air Force's YF-12A interceptor, a project that had already been canceled.⁴³ Following the President's announcement, two of

³⁴ John A. McCone, "Memorandum for the Record, Meeting with the President, Secretary McNamara, Mr. Bundy and DCI," 29 November 1963, DCI records ~~4000~~, *OSA History*, chap. 20, p. 73 ~~73-74~~.

⁴¹ *OSA History*, chap. 20, pp. 147-149 ~~147-149~~.

⁴² John A. McCone, Memorandum for the Record, "Discussion at the NSC Meeting. Attended by the President, all members and the four members of the President's personal staff, 29 February 1964," 2 March 1964, DCI records ~~4000~~, "OXCART Story," p. 14—erroneously identifies the date as 24 February—~~1964~~.

⁴³ President Johnson's use of the designator A-11 at the press conference has sometimes been called an error, but Kelly Johnson wrote the President's press release and chose this designator for security reasons because it referred to the earlier version of the aircraft that lacked the radar-defeating modifications of the A-12. Johnson, "Archangel log," 25 February 1964.



these aircraft were hastily flown to Edwards Air Force Base. From this point on, the Air Force versions of the OXCART were based at Edwards and provided a diversion so that the faster and higher flying A-12s at the ██████████ could continue testing out of the public eye.

The President's announcement did not mention the CIA's involvement in the project, which remained classified, but keeping the Agency's extensive role in the OXCART a secret was not an easy task. The first step had been to separate the Air Force's versions of the A-12 from the Agency's by moving the Air Force aircraft to California. Next, those firms that were to be given the new technology had to be briefed on the program and agree to abide by the same secrecy agreements then in force with Lockheed. Moreover, everyone witting of OXCART (including those no longer associated with the program, such as Allen Dulles, Richard Bissell, and General Cabell) had been briefed about the impending Presidential announcement, so that they would not think that the need for secrecy about OXCART had ended."

The process of surfacing versions of the OXCART continued on 25 July 1964, when President Johnson revealed the existence of a new Air Force reconnaissance aircraft, which he called the SR-71. Actually, the President was supposed to say RS-71 (for "reconnaissance-strike"). Deciding that renaming the aircraft was easier than correcting President Johnson, the Air Force invented a new category—"strategic reconnaissance"—to explain the SR-71's designation.

ADDITIONAL PROBLEMS DURING FINAL TESTING

The first A-12 crash occurred on 24 May 1963, when a detachment pilot, realizing the airspeed indication was confusing and erroneous, decided to eject. The pilot was unhurt, but the plane was destroyed when it crashed near Wendover, Utah. A cover story for the press described the plane as an F-105. All A-12s were grounded for a week while the accident was investigated. The malfunction was found to be caused by ice that had plugged up a pitot-static tube used to determine airspeed."

"OSA History, chap. 20, p. 76 (██████████)

"Ibid., pp. 69-70 (██████████)

APPROVED FOR RELEASE





Two more A-12s were lost in later testing. On 9 July 1964, article 133 crashed while landing when a pitch-control servo device froze, rolling the plane into a wing-down position. Ejecting from an altitude of 120 feet, the pilot was blown sideways out of the craft. Although he was not very high off the ground, his parachute did open and he landed during the parachute's first swing. Fortunately he was unharmed, and no news of the accident filtered out of the base. Eighteen months later, on 28 December 1965, article 126 crashed immediately after takeoff because of an improperly wired stability augmentation system. As in the previous crash, the pilot ejected safely, and there was no publicity connected with the crash. An investigation ordered by DCI McCone determined that the wiring error had resulted from negligence, not sabotage.*

The A-12 made its first long-range, high-speed flight on 27 January 1965. The flight lasted 100 minutes, 75 minutes of which were flown at speeds greater than Mach 3.1, and the aircraft covered 2,580 miles at altitudes between 75,600 and 80,000 feet. By this time, the OXCART was performing well. The engine inlet, camera, hydraulic, navigation, and flight-control systems all demonstrated acceptable reliability.

Nevertheless, as the OXCART began flying longer, faster, and higher, new problems arose. The most serious of these problems involved the aircraft's wiring. Continuing malfunctions of the inlet controls, communications equipment, ECM systems, and cockpit instruments were often attributable to wiring failures. Wiring connectors and components had to withstand temperatures above 800°F, structural flexing, vibration, and shock. Such demands were more than the materials could stand. Not all of the OXCART's problems could be traced to materiel failures, however, and Agency officials believed that careless maintenance by Lockheed employees also contributed to malfunctions."

Concerned that Lockheed would not be able to meet the OXCART's schedule for operational readiness, the Office of Special Activities' Director of Technology, ~~██████████~~ met with Kelly Johnson on 3 August 1965 to discuss the project's problems. Johnson not only assigned more top-level supervisors to the project but also

* Ibid., pp. 80-81 ~~██████████~~ "OXCART Story," pp. 17-18 ~~██████████~~

"OSA History, chap. 20, p. 94 ~~██████████~~

APPROVED FOR RELEASE



decided to go to ██████████ and take charge of the OXCART's development himself. His presence made a big difference, as can be seen in his notes in the project log:

I uncovered many items of a managerial, materiel and design nature.... I had meetings with vendors to improve their operation.... Changed supervision and had daily talks with them, going over in detail all problems on the aircraft.... Increased the supervision in the electrical group by 500%. We tightened up the inspection procedures a great deal and made inspection stick.

It appears that the problems are one-third due to bun engineering.... The addition of so many systems to the A-12 has greatly complicated the problems, but we did solve the overall problem."

These improvements in on-site management got the project back on schedule.

By 20 November 1965, the final validation flights for OXCART deployment were finished. During these tests, the OXCART achieved a maximum speed of Mach 3.29, an altitude of 90,000 feet, and sustained flight time above Mach 3.2 of 74 minutes. The maximum endurance test lasted six hours and 20 minutes. On 22 November, Kelly Johnson wrote to ██████████ head of the Office of Special Activities, stating, "The time has come when the bird should leave its nest."

Three years and seven months after its first flight in April 1962, the OXCART was ready for operational use. It was now time to find work for the most advanced aircraft ever conceived and built.

DISCUSSIONS ON THE OXCART'S FUTURE EMPLOYMENT

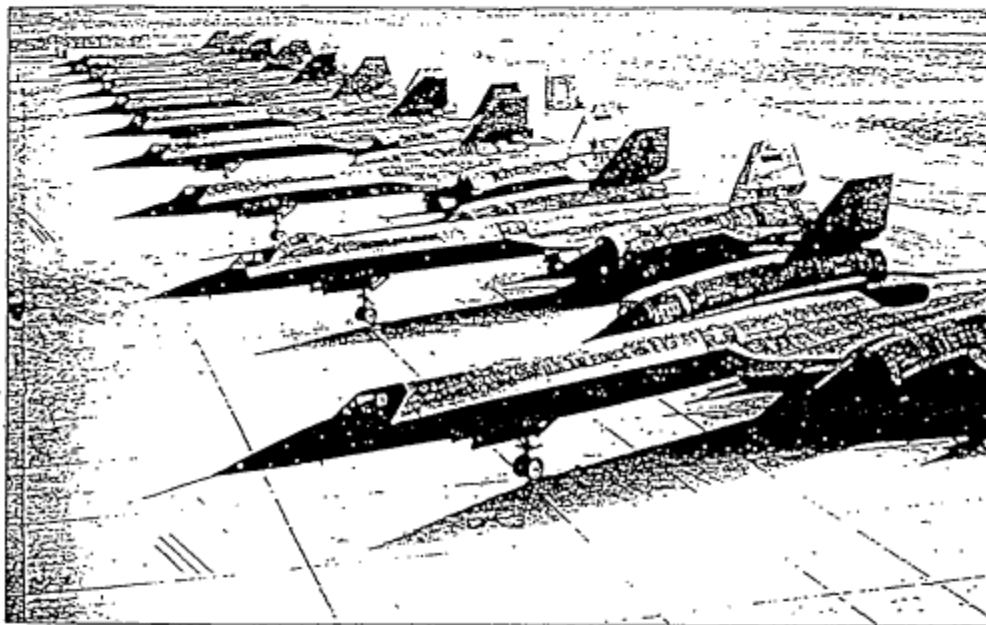
Although the OXCART had been designed to replace the U-2 as a strategic reconnaissance aircraft to fly over the Soviet Union, this use had become doubtful long before the OXCART was ready for operational use. The U-2 Affair of 1960 made Presidents very reluctant to consider overflights of the Soviet Union. Indeed, Presidents Eisenhower and Kennedy had both stated publicly that the United States would not conduct such overflights. In July 1963, Secretary of

"Johnson, "Archangel log," 5 August-30 April 1965.

██████████ "OXCART Story," p. 23

APPROVED FOR RELEASE





A-12

Defense McNamara told DCI McCone that he doubted that the OXCART would ever be used and suggested that improvements in [redacted] would very likely eliminate the need for the expensive OXCART program. Strongly disagreeing, McCone told McNamara that he had every intention of using OXCART aircraft to fly over the Soviet Union.

McCone raised this issue with President Kennedy in April 1963, at a time when the nation's [redacted] were experiencing a great number of failures and the intelligence community was clamoring for better photography to confirm or disprove allegations of the existence of an antiballistic missile system at Leningrad. Unconvinced by McCone's arguments for OXCART overflights, President Kennedy expressed the hope that some means might be devised for improving [redacted] instead."

"John A. McCone, Memorandum for the Record. "Summary of meeting with Secretary McNamara and Secretary Gilpatric, General Carter and Mr. McCone on 5 July 1962." 6 July 1962, DCI records (S); McCone, Memorandum for the File, "Meeting with the President—5:30—15 Apr 1963 in Palm Beach, Florida," DCI records (S).

APPROVALS FOR RELEASE



Although overflights of the Soviet Union appeared to be out of the question, the OXCART's eventual employment elsewhere in the world remained a strong possibility, particularly after the Cuban Missile Crisis of October 1962 demonstrated the continuing need for manned strategic reconnaissance aircraft. Since ~~the U-2s~~ had not been able to supply the kinds of coverage needed, U-2s had carried out numerous overflights of Cuba. Nevertheless, the U-2 remained vulnerable to surface-to-air missiles (as had once again been demonstrated by the downing of a SAC U-2 during the Missile Crisis), and project headquarters had even briefly considered sending the A-12 over Cuba in October 1962, even though the aircraft still lacked the required J58 engines and would have had to use much less powerful ones.⁵¹ After the Missile Crisis ended, Air Force U-2s continued to photograph Cuba under a tacit superpower understanding that such monitoring of the withdrawal of the missiles would proceed without interference. But the possibility of future Soviet or Cuban action against the U-2s remained, raising the dismaying prospect that the United States would not be able to tell if the Soviet Union was reintroducing ballistic missiles into Cuba.

Such fears became acute in the summer of 1964 after Soviet Premier Nikita Khrushchev told foreign visitors such as columnist Drew Pearson, former Senator William Benton, and Danish Prime Minister Jens Otto Krag that, once the US elections had been held in November, U-2s flying over Cuba would be shot down. Project headquarters therefore began preparing contingency plans (Project SKYLARK) for the possible employment of OXCART over Cuba, even though the new aircraft was not yet ready for operations. On 5 August 1964, the Acting DCI, Gen. Marshall S. Carter, ordered the project staff to achieve emergency operational readiness of the OXCART by 5 November 1964, in case Premier Khrushchev actually carried out his threat to shoot down U-2s.⁵²

To meet this deadline, the Office of Special Activities organized a detachment of five pilots and ground crews to conduct flights to validate camera performance and qualify pilots for Mach 2.8 operations. Simulating Cuban missions during training flights, the detachment

⁵¹ On 25 October 1962 Johnson noted in his "Archangel log": that the performance of an A-12 with J75 engines (as suggested by project headquarters for possible use over Cuba) would be "hardly spectacular."

⁵² Johnson, "Archangel log," 17 August 1964, ~~OSAH~~ "OXCART Story," p. 15, ~~OSAH~~ OSA History, chap. 20, p. 81 (~~OSAH~~ ~~OSAH~~).



[REDACTED]

demonstrated its ability to conduct overflights of Cuba by the 5 November deadline, which passed without any hostile action by the Soviets or Cubans. The detachment then worked to develop the capability for sustained operations with its five aircraft. All these preparations were valuable training for the OXCART program, even though the SKYLARK contingency plan was never put into effect. Since U-2s continued to satisfy collection requirements for Cuba, the A-12s were reserved for more critical situations.

When the Agency declared that OXCART had achieved emergency operational status on 5 November 1964, the aircraft was still not prepared for electronic warfare, as only one of the several planned electronic countermeasure devices had been installed. Nevertheless, a senior government panel decided that the OXCART could conduct initial overflights of Cuba without a full complement of warning and jamming devices, should the need for such missions arise.

One reason for the delay in completing OXCART's electronic warfare preparations was the Air Force's concern that OXCART use of existing ECM devices could, in the event of the loss of an OXCART over hostile territory, compromise the ECM equipment used by Air Force bombers and fighters. Even if OXCART's ECM devices were merely similar to military ECM systems, the Air Force still worried that their use would give the Soviets an opportunity to work out countermeasures.

Such concerns led the Agency to an entirely different approach to antiradar efforts in Project KEMPSTER. This project attempted to develop electron guns that could be mounted on the OXCART to generate an ion cloud in front of the plane that would reduce its radar cross section. Although this project proved unsuccessful, the CIA also developed a number of more conventional ECM devices for use in the OXCART.³⁴

As the OXCART's performance and equipment continued to improve, there was renewed consideration of deploying the aircraft overseas, particularly in Asia, where US military activity was increasing. On 18 March 1965, DCI McCone, Secretary of Defense McNamara, and Deputy Secretary of Defense Vance discussed the

³⁴ *OSA History*, chap. 20, pp. 149-151. [REDACTED] Notes on the OXCART project by [REDACTED], OSA records [REDACTED].

APPROVED FOR RELEASE



growing hazards confronting aerial reconnaissance of the [redacted] [redacted] In three years the [redacted] [redacted] and the Air Force had lost numerous reconnaissance drones. The three men agreed to go ahead with all the preparatory steps needed for the OXCART to operate over [redacted] so that it would be ready in case the President decided to authorize such missions.

Project BLACK SHIELD, the plan for Far East operations, called for OXCART aircraft to be based at Kadena airbase on Okinawa. In the first phase, three planes would be flown to Okinawa for 60-day periods, twice a year, an operation which would involve about 225 personnel. Later there would be a permanent detachment at Kadena. In preparation for the possibility of such operations, the Defense Department spent \$3.7 million to provide support facilities and real-time secure communications on the island by early autumn 1965.⁵⁴

In the summer of 1965, after the United States had begun introducing large numbers of troops into South Vietnam, Southeast Asia became another possible target for the OXCART. Because the continued use of U-2s for reconnaissance missions over North Vietnam was threatened by the deployment of Soviet-made surface-to-air missiles, McNamara asked the CIA on 3 June 1965 whether it would be possible to substitute OXCART aircraft for U-2s. The new DCI, Adm. William F. Raborn, replied that the OXCART could operate over Vietnam as soon as it had passed its final operational readiness tests.⁵⁵

Formal consideration of proposed OXCART missions involved the same approval process that was used for U-2 overflights. In late November 1965, after the OXCART had passed its final validation tests, the 303 Committee met to consider a proposal to deploy the OXCART to Okinawa to overfly Southeast Asia and [redacted]. Although the committee did not approve deployment, it ordered the development and maintenance of a quick-reaction capability, ready to deploy to Okinawa within 21 days after notification.

There the matter remained for more than a year. During the first half of 1966, DCI Raborn raised the issue of deploying the OXCART to Okinawa at five separate 303 Committee meetings but failed to win

⁵⁴ OSA History, chap. 20, pp. 90-91 [redacted]

⁵⁵ "OXCART Story," p. 21 [redacted]



[REDACTED]

sufficient support. The JCS and the PFIAB supported the CIA's advocacy of OXCART deployment. Top State and Defense Department officials, however, thought that the political risks of basing the aircraft in Okinawa—which would almost certainly disclose it to the Japanese—outweighed any gains from the intelligence the OXCART might gather. On 12 August 1966, the divergent views were presented to President Johnson, who upheld the 303 Committee's majority opinion against deployment for the time being."

The CIA then proposed an OXCART overflight of Cuba in order to test the aircraft's ECM systems in a hostile environment. On 15 September the 303 Committee considered and rejected this idea on the grounds that sending OXCART over Cuba "would disturb the existing calm prevailing in that area of our foreign affairs."

With operational missions still ruled out, proficiency training remained the main order of business. This led to improvements in mission plans and flight tactics that enabled the detachment to reduce the time required to deploy to Okinawa from 21 days to 15. Records continued to fall to the OXCART. On 21 December 1966, a Lockheed test pilot flew an A-12 for 16,408 kilometers over the continental United States in slightly more than six hours, for an average speed of 2,670 kilometers per hour (which included in-flight refueling at speeds as low as 970 kilometers per hour). This flight set a record for speed and distance unapproachable by any other aircraft."

Two weeks later, on 5 January 1967, an A-12 crashed after a fuel gauge malfunctioned and the aircraft ran out of fuel short of the runway. Pilot [REDACTED] ejected but was killed when he could not become separated from the ejection seat. To preserve the secrecy of the OXCART program, the Air Force informed the press that an SR-71 was missing and presumed down in Nevada. This loss, like the three preceding crashes, did not result from difficulties caused by high-speed, high-temperature flight but from traditional problems inherent in any new aircraft.

Proposals for OXCART operations continued to surface, and in May 1967 the CIA forwarded a detailed request to the 303 Committee to use the OXCART to collect strategic intelligence about a new

[REDACTED] "OXCART Story," p. 23. *OSA History*, chap. 20, pp. 110-111

"*OSA History*, chap. 20, p. 112 [REDACTED]

[REDACTED] "OXCART Story," p. 24

[REDACTED]



[REDACTED]

hoped that the A-12's passage would provoke Soviet air defense personnel to activate the Tallinn system radars in order to track the swift OXCART aircraft. As the A-12 made its dash down the Baltic, its Type-I camera would be filming the entire south coast. If Agency analysts were correct in their assumption that the Tallinn system was designed to counter high-altitude aircraft at long ranges, then the OXCART would be in jeopardy during this dash down the Baltic. Nevertheless, Agency weapons experts believed that the A-12 aircraft's speed and suite of electronic countermeasures would keep it safe from the standard Soviet surface-to-air missile installations.

While the A-12 was conducting its high-speed dash along the Baltic coast of Eastern Europe, the U-2 would be flying farther out to sea, safely beyond the range of all Soviet SAMs. [REDACTED]

Agency and Defense Department officials supported the proposed mission, but Secretary of State Dean Rusk strongly opposed it and the 303 Committee never forwarded the proposal to President Johnson. [REDACTED]

FIRST A-12 DEPLOYMENT: OPERATION BLACK SHIELD

Although the Tallinn mission was still being considered in May 1967, another possible employment for the OXCART came under discussion. This time the proposal was for OXCART to collect tactical rather than strategic intelligence. The cause was apprehension in Washington about the possible undetected introduction of surface-to-surface missiles into North Vietnam. When President Johnson asked for a proposal on the matter, the CIA suggested that the OXCART be used. While the State and Defense Departments were still examining the proposal's political risks, DCI Richard Helms

⁷ Memorandum for DDCI R. L. Taylor from [REDACTED] Utilizing the OXCART and the U-2," 4 May 1967. DS&T records [REDACTED]

Approved for Release



[REDACTED]

raised the issue at President Johnson's "Tuesday lunch" on 16 May. Helms got the President's approval, and the CIA put the BLACK SHIELD plan to deploy the OXCART to the Far East into effect later that same day."

The airlift of personnel and equipment to Kadena began on 17 May 1967, and on 22 May the first A-12 flew nonstop from [REDACTED] to Kadena in six hours and six minutes. A second aircraft arrived on 24 May. The third A-12 left on 26 May, but the pilot had trouble with the inertial navigation system and communications near Wake Island. He made a precautionary landing at Wake, where a pre-positioned emergency recovery team was located. The problem was corrected and the aircraft continued its flight to Kadena on the following day.

Before the start of the operation, the CIA briefed a number of key US and Allied officials on the operation. Included were the US Ambassadors and [REDACTED]

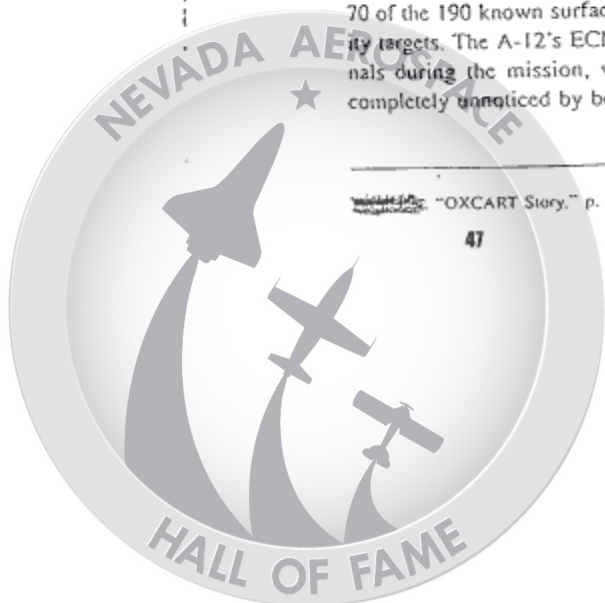
By 29 May 1967, 13 days after President Johnson's approval, BLACK SHIELD was ready to fly an operational mission. On 30 May, the detachment was alerted for a mission on the following day. As the takeoff time approached, Kadena was being deluged by rain, but, since weather over the target area was clear, flight preparations continued. The OXCART, which had never operated in heavy rain, taxied to the runway and took off.

This first BLACK SHIELD mission flew one flight path over North Vietnam and another over the demilitarized zone (DMZ). The mission was flown at Mach 3.1 and 80,000 feet and lasted three hours and 39 minutes. While over North Vietnam, the A-12 photographed 70 of the 190 known surface-to-air missile sites and nine other priority targets. The A-12's ECM equipment did not detect any radar signals during the mission, which indicated that the flight had gone completely unnoticed by both the Chinese and North Vietnamese.

"OXCART Story," p. 25

47

Approved for Release



[REDACTED]

During the next six weeks, there were alerts for 15 BLACK SHIELD missions, seven of which were actually flown. Only four detected hostile radar signals. By mid-July 1967, the BLACK SHIELD missions had provided sufficient evidence for analysts to conclude that no surface-to-surface missiles had been deployed in North Vietnam."

Project Headquarters in Langley planned and directed all operational BLACK SHIELD missions.

[REDACTED]

A typical mission over North Vietnam required refueling south of Okinawa, shortly after takeoff. After the planned photographic passes, the aircraft withdrew for a second aerial refueling in the Thailand area before returning to Kadena. So great was the plane's speed that it spent only 12.5 minutes over Vietnam during a "single-pass" mission, and 21.5 minutes during a "two-pass" mission. Because of its wide 86-mile turning radius, the plane occasionally crossed into [REDACTED] when getting into position for a second pass.

After the aircraft landed, the camera film was removed and sent by special plane to processing facilities in the United States. By late summer, however, an Air Force photo laboratory in Japan began doing the processing in order to place the photointelligence in the hands of US commanders in Vietnam within 24 hours of a mission's completion.

BLACK SHIELD activity continued unabated during the second half of 1967. From 16 August to 31 December 1967, 26 missions were alerted and 15 were flown. On 17 September one SAM site tracked the vehicle with its acquisition radar but was unsuccessful with its FAN SONG guidance radar. It was not until 28 October that a North Vietnamese SAM site launched a missile at the OXCART. Mission photography documented the event with photographs of missile smoke above the SAM firing site and pictures of the missile and its contrail. Electronic countermeasures equipment aboard the OXCART performed well, and the missile did not endanger the aircraft.

[REDACTED] "OXCART Story," pp. 25-28. OSA History, chap. 20, pp. 119-124, annex 137.

APPROVED FOR RELEASE



Initial storage arrangements for A-12s at Palmdale



POSSIBLE SUCCESSORS TO THE OXCART

The OXCART was the last high-altitude reconnaissance aircraft produced for the CIA, although the Office of Special Activities did briefly consider several possible successors to the OXCART during the mid-1960s. The first of these, known as Project ISINGLASS, was prepared by General Dynamics to utilize technology developed for its Convair Division's earlier FISH proposal and its new F-111 fighter in order to create an aircraft capable of Mach 4-5 at 100,000 feet. General Dynamics completed its feasibility study in the fall of 1964, and OSA took no further action because the proposed aircraft would still be vulnerable to existing Soviet countermeasures. In 1965 a more ambitious design from McDonnell Aircraft came under consideration as Project RHEINBERRY (although some of the work seems to have come under the ISINGLASS designation as well). This proposal featured a rocket-powered aircraft that would be launched from a B-52 mother ship and ultimately reach speeds as high as Mach 20 and altitudes of up to 200,000 feet. Because building this aircraft would have involved tremendous technical challenges and correspondingly high costs, the Agency was not willing to embark on such a program at a time when the main emphasis in overhead reconnaissance had shifted from aircraft to satellites. As a result, when the OXCART program ended in the summer of 1968, no more advanced successor was waiting in the wings—only the veteran U-2.

APPROVED FOR RELEASE



[REDACTED]

[REDACTED]

[REDACTED]

SUMMARY OF THE OXCART PROGRAM

Intended to replace the U-2 as a collector of strategic intelligence, the OXCART was never used for this purpose: its brief deployment was strictly for obtaining tactical intelligence and its photographic product contributed very little to the Agency's strategic intelligence mission. By the time OXCART became operational, ~~the U-2 had~~ had filled the role originally conceived for it. The most advanced aircraft of the 20th century had become an anachronism before it was ever used operationally."

The OXCART did not even outlast the U-2, the aircraft it was supposed to replace. The OXCART lacked the quick-response capability of the smaller craft: a U-2 unit could be activated overnight, and within a week it could deploy abroad, fly sorties, and return to home base. The OXCART planes required precise logistic planning for fuel and emergency landing fields, and their inertial guidance systems needed several days for programming and stabilization. Aerial tankers had to be deployed in advance along an OXCART's flight route and be provisioned with the highly specialized fuel used by the J58 engines. All of this required a great deal of time and the effort of several hundred people. A U-2 mission could be planned and flown with a third fewer personnel.

Although the OXCART program created a strategic reconnaissance aircraft with unprecedented speed, range, and altitude, the program's most important contributions lay in other areas: aerodynamic design, high-impact plastics, engine performance, cameras, electronic countermeasures, pilot life-support systems, antiradar devices, use of nonmetallic materials for major aircraft assemblies, and improvements in milling, machining, and shaping titanium. In all of these areas, the OXCART pushed back the frontiers of aerospace technology and helped lay the foundation for future "stealth" research.

"On 26 January 1967 Kelly Johnson noted in his "Archangel log" I think back to 1959, before we started this airplane, to discussions with Dick Bassett where we seriously considered the problem of whether there would be one more round of aircraft before the satellites took over. We jointly agreed there would be just one round, and not two. That seems to have been a very accurate evaluation, as it seems that 30 SR-71's give us enough overflight reconnaissance capability and we don't need the additional 10 Oxcart aircraft.

50

APPROVED FOR RELEASE



The only time the enemy came close to downing an OXCART was on 30 October 1967. During his first pass over North Vietnam, pilot [REDACTED] detected radar tracking. Two SAM sites prepared to launch missiles but neither did. During [REDACTED] second pass the North Vietnamese fired at least six missiles at the OXCART, each confirmed by vapor trails on mission photography. The pilot saw these vapor trails and witnessed three missile detonations near but behind the A-12, which was traveling at Mach 3.1 at about 84,000 feet. Postflight inspection of the aircraft revealed that a piece of metal had penetrated the underside of the right wing, passed through three layers of titanium, and lodged against a support structure of the wing tank. The fragment was not a warhead pellet but probably debris from one of the missile detonations that the pilot observed.⁴²

BLACK SHIELD missions continued during the first three months of 1968, with four missions flown over North Vietnam out of 14 alerts. The last OXCART overflight of Vietnam took place on 8 March 1968. During this same three-month period, the OXCART made its first overflight of North Korea after the USS Pueblo was seized on 23 January 1968. The goal of this mission was to discover whether the North Koreans were preparing any large-scale hostile move in the wake of this incident. [REDACTED]

Secretary of State Dean Rusk was reluctant to endorse a second mission over North Korea for fear of diplomatic repercussions should the aircraft come down in hostile territory. The Secretary was assured that the plane could transit North Korea in seven minutes and was unlikely to land in either North Korea or China. The 303 Committee then endorsed a second mission over North Korea, which was flown on 19 February. A third and final overflight of North Korea on 8 May 1968 proved to be the last operational deployment of the OXCART aircraft.⁴³

THE END OF THE OXCART PROGRAM

Almost a decade had elapsed between the time when the concept for the OXCART aircraft was first examined and the first A-12 was operationally deployed. Now after only 29 operational missions, the most

⁴² [REDACTED] "OXCART Story," p. 28.

⁴³ Ibid., pp. 28-29.



[REDACTED]

[REDACTED]

advanced aircraft ever built was to be put out to pasture. The abandonment of the OXCART did not result from any shortcomings of the aircraft; the causes lay in fiscal pressures and competition between the reconnaissance programs of the CIA and the Air Force.

Throughout the OXCART program, the Air Force had been exceedingly helpful; it gave financial support, conducted the refueling program, provided operational facilities at Kadena, and airlifted OXCART personnel and supplies to Okinawa for the Vietnam and Korean operations. Air Force orders for variants of the CIA's A-12—the YF-12A interceptor and the SR-71 reconnaissance aircraft—had helped lower development and procurement costs for the OXCART. Nevertheless, once the Air Force had built up its own fleet of reconnaissance aircraft, budgetary experts began to criticize the existence of two expensive fleets of similar aircraft.

In November 1965, the very month that the A-12 had been declared operational, the Bureau of the Budget circulated a memorandum that expressed concern about the costs of the A-12 and SR-71 programs. It questioned both the total number of planes required for the combined fleets, and the necessity for a separate CIA fleet. The memorandum recommended phasing out the A-12 program by September 1966 and stopping any further procurement of the SR-71

APPROVED FOR RELEASE

See 1964-1965 RELEASE



models. The Secretary of Defense rejected this recommendation, presumably because the SR-71 would not be operational by September 1966.⁶⁴

In July 1966, at the Bureau of the Budget's suggestion, a study group was established to look for ways to reduce the cost of the OXCART and SR-71 programs. The study group consisted of [redacted] from the Bureau of the Budget, [redacted] from the Department of Defense, and [redacted] from CIA. The study group listed three possible courses of action: maintain both fleets, mothball the A-12s but share the SR-71s between CIA and the Air Force, or mothball the A-12s and assign all missions to Air Force SR-71s. On 12 December 1966, four high-level officials met to consider these alternatives. Over the objections of DCI Helms, the other three officials—Deputy Secretary of Defense Cyrus Vance, Bureau of the Budget Director Charles L. Schultze, and Presidential Scientific Adviser Donald F. Hornig—decided to terminate the OXCART fleet. Concerned that this recommendation would strip the CIA of its supersonic reconnaissance capability, Helms then asked that the SR-71 fleet be shared between CIA and the Air Force.⁶⁵

Four days later, Schultze handed Helms a draft memorandum for the President requesting a decision either to share the SR-71 fleet between CIA and the Air Force or to terminate the CIA capability entirely. Having just received new information indicating that the SR-71's performance was inferior to that of the A-12, Helms asked for another meeting to review this data. His concern was that the SR-71 could not match the photographic coverage that the A-12 could provide. Only one of the SR-71's three camera systems was working anywhere near the original specifications, and that was its Operational Objective system which could only photograph a swath 28 miles wide with a resolution of 28 to 30 inches. The A-12's Type-I P-E camera could photograph a swath 72 miles wide with a nadir resolution of 12 to 18 inches and oblique resolution of 54 inches. Thus, the A-12's camera covered three times as much territory as the SR-71's camera and did so with better resolution. In addition, the A-12 could fly 2,000 to 5,000 feet higher than the SR-71 and was also faster, with a maximum speed of Mach 3.1 compared with the SR-71's Mach 3.0.⁶⁶

⁶⁴ OSA History, chap. 20, p. 130 [redacted] "OXCART Story," p. 30 [redacted].

⁶⁵ OSA History, chap. 20, pp. 130-133 [redacted] "OXCART Story," pp. 30-31 (5).

⁶⁶ "OXCART Story," p. 31 (5); OSA History, pp. 133-134 [redacted].



[REDACTED]

In spite of Helms's request and the strength of his arguments, Bureau of the Budget memorandum was submitted to President Johnson. On 28 December 1966, the President approved the termination of the OXCART program by 1 January 1968.

This decision meant that CIA had to develop a schedule for orderly phaseout of the A-12. This activity was known as Project SCOPE COTTON. Project headquarters informed Deputy Defense Secretary Vance on 10 January 1967 that the A-12s would gradually be placed in storage, with the process to be completed by the end of January 1968. In May 1967, Vance directed that SR-71s would assume responsibility for Cuban overflights by 1 July 1967 and would add responsibility for overflights of Southeast Asia by 1 December 1967. Until these capabilities were developed, OXCART was to remain able to conduct assignments on a 15-day notice for Southeast Asia and a seven-day notice for Cuba.⁴⁷

All these arrangements were made before the OXCART had conducted a single operational mission, which did not occur until 31 May 1967. In the months that followed the initiation of operations in Asia, the OXCART demonstrated its exceptional technical capabilities. Soon some high-level Presidential advisers and Congressional leaders began to question the decision to phase out OXCART, and the issue was reopened.

The CIA contended that the A-12 was the better craft because it flew higher, faster, and had superior cameras. The Air Force maintained that its two-seat SR-71 had a better suite of sensors, with three different cameras (area search, spotting, and mapping), infrared detectors, side-looking aerial radar, and ELINT-collection gear. In an effort to resolve this argument, the two aircraft were pitted against each other in a flyoff codenamed NICE GIRL. On 3 November 1967, an A-12 and an SR-71 flew identical flight paths, separated in time by one hour, from north to south roughly above the Mississippi River. The data collected during these missions were evaluated by representatives of the CIA, DIA, and other Defense Department intelligence organizations.

The results proved inconclusive. Both photographic systems provided imagery of sufficient quality for analysis. The A-12 Type-1 camera's 72-mile swath width and 5,000-foot film supply were superior to the SR-71 Operational Objective camera's 28-mile swath and

⁴⁷ "OXCART Story," p. 31; *OSA History*, p. 138.



3,300-foot film supply. On the other hand, the SR-71's infrared, side-looking aerial radar, and ELINT/COMINT equipment provided some unique intelligence not available from the A-12. Air Force planners admitted, however, that some of this equipment would have to be sacrificed in order to provide the SR-71 with ECM gear."

Although the flyoff had not settled the question of which aircraft was superior, the OXCART did win a temporary reprieve in late November 1967. The Johnson administration decided to keep both fleets for the time being, particularly because the OXCART was actually flying missions over North Vietnam. With expenditures for the Vietnam war rising steadily, the question of reducing the costs of competing reconnaissance programs was bound to surface again. In the spring of 1968, there was yet another study of the OXCART and SR-71 programs. On 16 May 1968, the new Secretary of Defense, Clark Clifford, reaffirmed the original decision to terminate the OXCART program and store the aircraft. President Johnson confirmed this decision on 21 May."

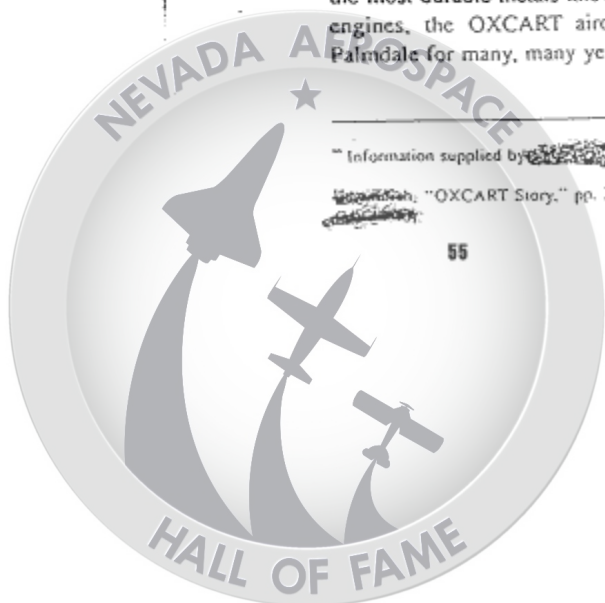
Project headquarters selected 8 June 1968 as the earliest possible date for phasing out all OXCART aircraft. Those A-12s already at the [redacted] were placed in storage, and the aircraft on Okinawa were scheduled to return by 8 June. Unfortunately, tragedy struck before this redeployment took place. On 4 June 1968 during a test flight from Kadena to check out a new engine, an A-12 disappeared 520 miles east of Manila. Search and rescue missions found no trace of the plane or its pilot, Jack W. Weeks. Several days later the remaining two A-12s left Okinawa to join the other eight OXCART aircraft in storage at Palmdale, California. Because the A-12s were smaller than either of the Air Force's versions, the only parts that could be salvaged for Air Force use were the J58 engines. The OXCART's outstanding Perkin-Elmer camera cannot be used in the SR-71 because the two-seater Air Force aircraft has a smaller camera compartment than that of the A-12. Constructed from one of the most durable metals known to man but unable to fly for want of engines, the OXCART aircraft are fated to remain inactive at Palmdale for many, many years.

"Information supplied by [redacted]"

[redacted] "OXCART Story," pp. 32-33; OSA History, chap. 20, pp. 143-146 [redacted]"

55

APPROVED FOR RELEASE



Title:	(EST PUB DATE) THE CENTRAL INTELLIGENCE AGENCY AND OVERHEAD RECONNAISSANCE - TH
Abstract:	
Pages:	0007
Pub Date:	1/1/1974
Release Date:	9/18/1998
Keywords:	OXCART A-12 AIRCRAFT
Case Number:	F-1996-01541
Copyright:	0
Release Decision:	RIPPUB
Classification:	U



THE CENTRAL
INTELLIGENCE
AGENCY AND
OVERHEAD
RECONNAISSANCE

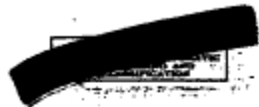
The U-2 and OXCART
Programs, 1954 - 1974



Secret

WARNING

This document contains information affecting the national security of the United States within the meaning of the espionage laws U. S. Code Title 18, Sections 793, 794 and 798. The law prohibits its transmission or the revelation of its contents in any manner to an unauthorized person, as well as its use in any manner prejudicial to the safety or interest of the United States or for the benefit of any foreign government to the detriment of the United States. It is to be seen only by personnel especially indoctrinated and authorized to receive information in the designated control channels. Its security must be maintained in accordance with regulations pertaining to [REDACTED] Control System.



~~Secret~~ NOFORN

The Central Intelligence Agency
and Overhead Reconnaissance:

The U-2 and OXCART Programs, 1954-1974



History Staff
Central Intelligence Agency
Washington, D.C.

1992

~~Secret~~



Although overflights of the Soviet Union appeared to be out of the question, the OXCART's eventual employment elsewhere in the world remained a strong possibility, particularly after the Cuban Missile Crisis of October 1962 demonstrated the continuing need for manned strategic reconnaissance aircraft. Since satellites had not been able to supply the kinds of coverage needed, U-2s had carried out numerous overflights of Cuba. Nevertheless, the U-2 remained vulnerable to surface-to-air missiles (as had once again been demonstrated by the downing of a SAC U-2 during the Missile Crisis), and project headquarters had even briefly considered sending the A-12 over Cuba in October 1962, even though the aircraft still lacked the required J58 engines and would have had to use much less powerful ones.¹¹ After the Missile Crisis ended, Air Force U-2s continued to photograph Cuba under a tacit superpower understanding that such monitoring of the withdrawal of the missiles would proceed without interference. But the possibility of future Soviet or Cuban action against the U-2s remained, raising the dismaying prospect that the United States would not be able to tell if the Soviet Union was reintroducing ballistic missiles into Cuba.

Such fears became acute in the summer of 1964 after Soviet Premier Nikita Khrushchev told foreign visitors such as columnist Drew Pearson, former Senator William Benton, and Danish Prime Minister Jens Otto Krag that, once the US elections had been held in November, U-2s flying over Cuba would be shot down. Project headquarters therefore began preparing contingency plans (Project SKYLARK) for the possible employment of OXCART over Cuba, even though the new aircraft was not yet ready for operations. On 5 August 1964, the Acting DCI, Gen. Marshall S. Carter, ordered the project staff to achieve emergency operational readiness of the OXCART by 5 November 1964, in case Premier Khrushchev actually carried out his threat to shoot down U-2s.¹²

To meet this deadline, the Office of Special Activities organized a detachment of five pilots and ground crews to conduct flights to validate camera performance and qualify pilots for Mach 2.8 operations. Simulating Cuban missions during training flights, the detachment

¹¹ On 23 October 1962 Johnson noted in his "Archangel log": that the performance of an A-12 with J75 engines (as suggested by project headquarters for possible use over Cuba) would be "hardly spectacular."

¹² Johnson, "Archangel log," 17 August 1964; [redacted] "OXCART Story," p. 19 (S); OSA History, chap. 20, p. 81 (TTS Codeword).



growing hazards confronting aerial reconnaissance of the People's Republic of China. In three years the Agency had lost four U-2s over China, and the Air Force had lost numerous reconnaissance drones. The three men agreed to go ahead with all the preparatory steps needed for the OXCART to operate over China so that it would be ready in case the President decided to authorize such missions.

Project BLACK SHIELD, the plan for Far East operations, called for OXCART aircraft to be based at Kadena airbase on Okinawa. In the first phase, three planes would be flown to Okinawa for 60-day periods, twice a year, an operation which would involve about 225 personnel. Later there would be a permanent detachment at Kadena. In preparation for the possibility of such operations, the Defense Department spent \$3.7 million to provide support facilities and real-time secure communications on the island by early autumn 1965.⁴

In the summer of 1965, after the United States had begun introducing large numbers of troops into South Vietnam, Southeast Asia became another possible target for the OXCART. Because the continued use of U-2s for reconnaissance missions over North Vietnam was threatened by the deployment of Soviet-made surface-to-air missiles, McNamara asked the CIA on 3 June 1965 whether it would be possible to substitute OXCART aircraft for U-2s. The new DCI, Adm. William F. Raborn, replied that the OXCART could operate over Vietnam as soon as it had passed its final operational readiness tests.⁵

Formal consideration of proposed OXCART missions involved the same approval process that was used for U-2 overflights. In late November 1965, after the OXCART had passed its final validation tests, the 303 Committee met to consider a proposal to deploy the OXCART to Okinawa to overfly Southeast Asia and China. Although the committee did not approve deployment, it ordered the development and maintenance of a quick-reaction capability, ready to deploy to Okinawa within 21 days after notification.

There the matter remained for more than a year. During the first half of 1966, DCI Raborn raised the issue of deploying the OXCART to Okinawa at five separate 303 Committee meetings but failed to win

⁴ OSA History, chap. 20, pp. 90-91 (TS Codeword).

⁵ "OXCART Story," p. 21 (S).



sufficient support. The JCS and the PFLAB supported the CIA's advocacy of OXCART deployment. Top State and Defense Department officials, however, thought that the political risks of basing the aircraft in Okinawa—which would almost certainly disclose it to the Japanese—outweighed any gains from the intelligence the OXCART might gather. On 12 August 1966, the divergent views were presented to President Johnson, who upheld the 303 Committee's majority opinion against deployment for the time being.²⁶

The CIA then proposed an OXCART overflight of Cuba in order to test the aircraft's ECM systems in a hostile environment. On 15 September the 303 Committee considered and rejected this idea on the grounds that sending OXCART over Cuba "would disturb the existing calm prevailing in that area of our foreign affairs."²⁷

With operational missions still ruled out, proficiency training remained the main order of business. This led to improvements in mission plans and flight tactics that enabled the detachment to reduce the time required to deploy to Okinawa from 21 days to 15. Records continued to fall to the OXCART. On 21 December 1966, a Lockheed test pilot flew an A-12 for 16,408 kilometers over the continental United States in slightly more than six hours, for an average speed of 2,670 kilometers per hour (which included in-flight refueling at speeds as low as 970 kilometers per hour). This flight set a record for speed and distance unapproachable by any other aircraft.²⁸

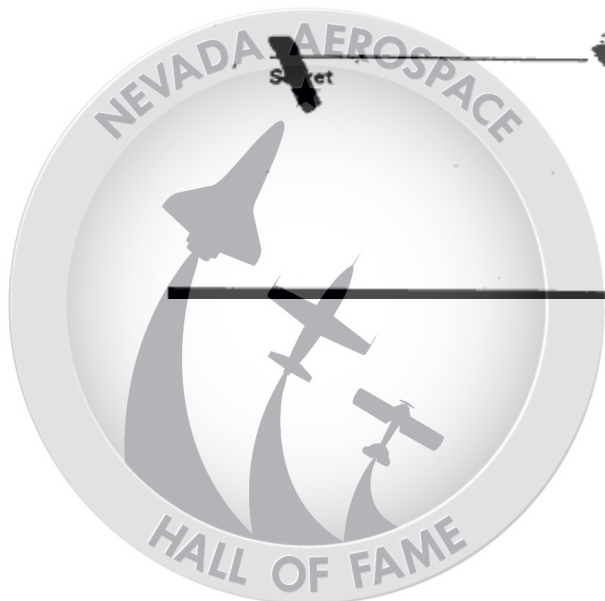
Two weeks later, on 5 January 1967, an A-12 crashed after a fuel gauge malfunctioned and the aircraft ran out of fuel short of the runway. Pilot [REDACTED] ejected but was killed when he could not become separated from the ejection seat. To preserve the secrecy of the OXCART program, the Air Force informed the press that an SR-71 was missing and presumed down in [REDACTED]. This loss, like the three preceding crashes, did not result from difficulties caused by high-speed, high-temperature flight but from traditional problems inherent in any new aircraft.

Proposals for OXCART operations continued to surface, and in May 1967 the CIA forwarded a detailed request to the 303 Committee to use the OXCART to collect strategic intelligence about a new

[REDACTED] "OXCART Story," p. 23 (S); *OSA History*, chap. 20, pp. 110-111 (TS Codeword).

²⁷ *OSA History*, chap. 20, p. 112 (TS Codeword).

[REDACTED] "OXCART Story," p. 24 (S).



Title:	STUDIES IN INTELLIGENCE VOL 26 NO 2 SUMMER 1982 - THE OXCART STORY
Abstract:	
Pages:	0022
Pub Date:	7/1/1982
Release Date:	11/17/1989
Keywords:	U-2 STUDIES IN INTELLIGENCE LOCKHEED AIRCRAFT A-12A-11 JOHNSON CLARENCE L KELLY OXCART PROGRAM POWERS GARY FRANCIS PROJECT GUSTO SCHALK LOUIS
Case Number:	EO-1992-01091
Copyright:	0
Release Decision:	RIFPUB
Classification:	U



THE OXCART STORY

One spring day in 1962 a test pilot named Louis Schalk, employed by the Lockheed Aircraft Corporation, took off in an aircraft the likes of which had never been seen before. A casual observer would have been startled by the appearance of this vehicle; he would perhaps have noticed especially its extremely long, slim, shape, its two enormous jet engines, its long, sharp, projecting nose, and its swept-back wings which appeared far too short to support the fuselage in flight. He might well have realized that this was a revolutionary airplane; he could not have known that it would be able to fly at three times the speed of sound for more than 3,000 miles without refueling, or that toward the end of its flight, when fuel began to run low, it could cruise at over 90,000 feet. Still less would he have known of the equipment it was to carry, or of the formidable problems attending its design and construction.

There was, of course, no casual observer present. The aircraft had been designed and built for reconnaissance; it was projected as a successor to the U-2. Its development had been carried out in profound secrecy. Despite the numerous designers, engineers, skilled and unskilled workers, administrators, and others who had been involved in the affair, no authentic accounts, and indeed scarcely any accounts at all, had leaked.

The official designation of the aircraft was A-12. By a sort of inspired perversity, however, it came to be called OXCART, a code word also applied to the program under which it was developed. The secrecy in which it was so long shrouded has lifted a bit, and the purpose of this article is to give some account of the inception, development, operation, and untimely demise of this remarkable airplane. The OXCART no longer flies, but it left a legacy of technological achievement which points the way to new projects. And it became the progenitor of a similar reconnaissance vehicle called the SR-71, whose existence is well known to press and public.

The U-2 dated from 1954, when its development began under the direction of a group headed by Richard M. Bissell of CIA. In June 1956, the aircraft became operational, but officials predicted that its useful lifetime over the USSR could hardly be much more than 18 months or two years. Its first flights over Soviet territory revealed that the air defense warning system not only detected but tracked it quite accurately. Yet it remained a unique and invaluable source of intelligence information for almost four years, until on 1 May 1960, Francis Gary Powers was shot down near Sverdlovsk.

Studies in Intelligence, Vol. 26, No. 2, Summer 1982

NEVADA

HALL OF FAME

Meanwhile, even as the U-2 commenced its active career, efforts were under way to make it less vulnerable. The hope was to reduce the vehicle's radar cross-section, so that it would become less susceptible to detection. New developments in radar-absorbing materials were tried out and achieved considerable success, though not enough to solve the problem. Various far-out designs were explored, most of them seeking to create an aircraft capable of flying at extremely high altitudes, though still at relatively slow speed. None of them proved practicable.

Eventually, in the fall of 1957, Bissell arranged with a contractor for a job of operations analysis to determine how far the probability of shooting down an airplane varied respectively with the plane's speed, altitude, and radar cross-section. This analysis demonstrated that supersonic speed greatly reduced the chances of detection by radar. The probability of being shot down was not of course reduced to zero, but it was evident that the supersonic line of approach was worth serious consideration. Therefore, from this time on, attention focussed increasingly on the possibility of building a vehicle which could fly at extremely high speeds as well as at great altitudes, and which would also incorporate the best that could be attained in radar-absorbing capabilities. Lockheed Aircraft Corporation and Convair Division of General Dynamics were informed of the general requirement, and their designers set to work on the problem without as yet receiving any contract or funds from the government. From the fall of 1957 to late 1958 these designers constantly refined and adapted their respective schemes.

Bissell realized that development and production of such an aircraft would be exceedingly expensive, and that in the early stages at least it would be doubtful whether the project could succeed. To secure the necessary funds for such a program, high officials would have to receive the best and most authoritative presentation of whatever prospects might unfold. Accordingly, he got together a panel consisting of two distinguished authorities on aerodynamics and one physicist, with E. M. Land of the Polaroid Corporation as chairman. Between 1957 and 1959 this panel met about six times, usually in Land's office in Cambridge. Lockheed and Convair designers attended during parts of the sessions. So also did the Assistant Secretaries of the Air Force and Navy concerned with research and development, together with one or two of their technical advisors. One useful consequence of the participation of service representatives was that bureaucratic and jurisdictional feuds were reduced virtually to nil. Throughout the program both Air Force and Navy gave valuable assistance and cooperation.



As the months went by, the general outlines of what might be done took shape in the minds of those concerned. Late in November 1958, the members of the panel held a crucial meeting. They agreed that it now appeared feasible to build an aircraft of such speed and altitude as to be very difficult to track by radar. They recommended that the President be asked to approve in principle a further prosecution of the project, and to make funds available for further studies and tests. The President and his Scientific Advisor, Dr. James Killian, were already aware of what was going on, and when CIA officials went to them with the recommendation of the panel they received a favorable hearing. The President gave his approval. Lockheed and Convair were then asked to submit definite proposals, funds were made available to them, and the project took on the code name GUSTO.

Less than a year later the two proposals were essentially complete, and on 20 July 1959, the President was again briefed. This time he gave final approval, which signified that the program could get fully under way.

The next major step was to choose between the Lockheed and Convair designs. On 20 August 1959, specifications of the two proposals were submitted to a joint DOD/USAF/CIA selection panel:

	<u>Lockheed</u>	<u>Convair</u>
Speed	Mach 3.2	Mach 3.2
Range (total)	4,120 n.m.	4,000 n.m.
Range (at altitude)	3,800 n.m.	3,400 n.m.
Dimensions		
Length	102 ft.	79.5 ft.
Span	57 ft.	56.0 ft.
Gross Weight	110,000 lbs.	101,700 lbs.
Fuel Weight	64,600 lbs.	62,000 lbs.
First Flight	22 months	22 months

The Lockheed design was selected, Project GUSTO terminated, and the program to develop a new U-2 follow-on aircraft was named OXCART. On 3 September 1959, CIA authorized Lockheed to proceed with antiradar studies, aerodynamic structural tests, and engineering designs, and on 30 January 1960 gave the green light to produce 12 aircraft.

Pratt and Whitney Division of United Aircraft Corporation had been involved in discussions of the project, and undertook to develop the propulsion system. Their J-58 engine, which was to be used in the A-12, had been sponsored originally by the US Navy for its own purposes, and was to be capable of a speed of



Mach 3.0. Navy interest in the development was diminishing, however, and the Secretary of Defense had decided to withdraw from the program at the end of 1959. CIA's requirement was that the engine and airframe be further developed and optimized for a speed of Mach 3.2. The new contract called for initial assembly of three advanced experimental engines for durability and reliability testing, and provision of three engines for experimental flight testing in early 1961.

Lockheed's designer was Clarence L. (Kelly) Johnson, creator of the U-2, and he called his new vehicle not A-12 but A-11. Its design exhibited many innovations. Supersonic airplanes, however, involve a multitude of extremely difficult design problems. Their payload-range performance is highly sensitive to engine weight, structural weight, fuel consumption, and aerodynamic efficiency. Small mistakes in predicting these values can lead to large errors in performance. Models of the A-11 were tested and retested, adjusted and readjusted, during thousands of hours in the wind tunnel. Johnson was confident of his design, but no one could say positively whether the bird would fly, still less whether it would fulfill the extremely demanding requirements laid down for it.

To make the drawings and test the model was one thing; to build the aircraft was another. The most numerous problems arose from the simple fact that in flying through the atmosphere at its designed speed the skin of the aircraft would be subjected to a temperature of more than 550 degrees Fahrenheit. For one thing, no metal hitherto commonly used in aircraft production would stand this temperature, and those which would do so were for the most part too heavy to be suitable for the purpose in hand.

During the design phase Lockheed evaluated many materials and finally chose an alloy of titanium B120, characterized by great strength, relatively light weight, and good resistance to high temperatures. Titanium was also scarce and very costly. Methods for milling it and controlling the quality of the product were not fully developed. Of the early deliveries from Titanium Metals Corporation some 80 percent had to be rejected, and it was not until 1961, when a delegation from headquarters visited the officials of that company, informed them of the objectives and high priority of the OXCART program, that the problems were solved.

But this only solved an initial problem. One of the virtues of titanium was its exceeding hardness, but this very virtue gave rise to immense difficulties in machining and shaping the material. Drills which worked well on aluminum soon broke into pieces; new ones had to be devised. Assembly-line production was impossible; each of the small OXCART fleet was,

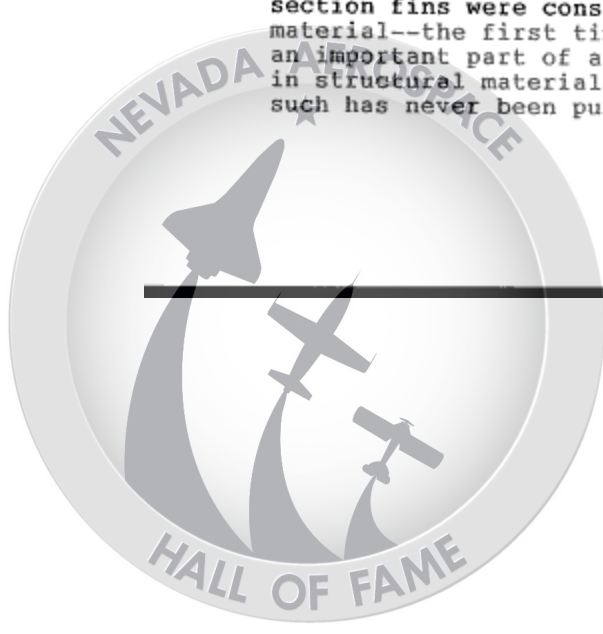


so to speak, turned out by hand. The cost of the program mounted well above original estimates, and it soon began to run behind schedule. One after another, however, the problems were solved, and their solution constituted the greatest single technological achievement of the entire enterprise. Henceforth it became practicable, if expensive, to build aircraft out of titanium.

Since every additional pound of weight was critical, adequate insulation was out of the question. The inside of the aircraft would be like a moderately hot oven. The pilot would have to wear a kind of space suit, with its own cooling apparatus, pressure control, oxygen supply, and other necessities for survival. The fuel tanks, which constituted by far the greater part of the aircraft, would heat up to about 350 degrees, so that special fuel had to be supplied and the tanks themselves rendered inert with nitrogen. Lubricating oil was formulated for operation at 600 degrees F., and contained a diluent in order to remain fluid at operation below 40 degrees. Insulation on the plane's intricate wiring soon became brittle and useless. During the lifetime of the OXCART no better insulation was found; the wiring and related connectors had to be given special attention and handling at great cost in labor and time.

Then there was the unique problem of the camera window. The OXCART was to carry a delicate and highly sophisticated camera, which would look out through a quartz glass window. The effectiveness of the whole system depended upon achieving complete freedom from optical distortion despite the great heat to which the window would be subjected. Thus the question was not simply one of providing equipment with resistance to high temperature, but of assuring that there should be no unevenness of temperature throughout the area of the window. It took three years and two million dollars to arrive at a satisfactory solution. The program scored one of its most remarkable successes when the quartz glass was successfully fused to its metal frame by an unprecedented process involving the use of high frequency sound waves.

Another major problem of different nature was to achieve the low radar cross-section desired. The airframe areas giving the greatest radar return were the vertical stabilizers, the engine inlet, and the forward side of the engine nacelles. Research in ferrites, high-temperature absorbing materials and high-temperature plastic structures was undertaken to find methods to reduce the return. Eventually the vertical tail section fins were constructed from a kind of laminated "plastic" material--the first time that such a material had been used for an important part of an aircraft's structure. With such changes in structural materials, the A-11 was redesignated A-12, and as such has never been publicly disclosed.

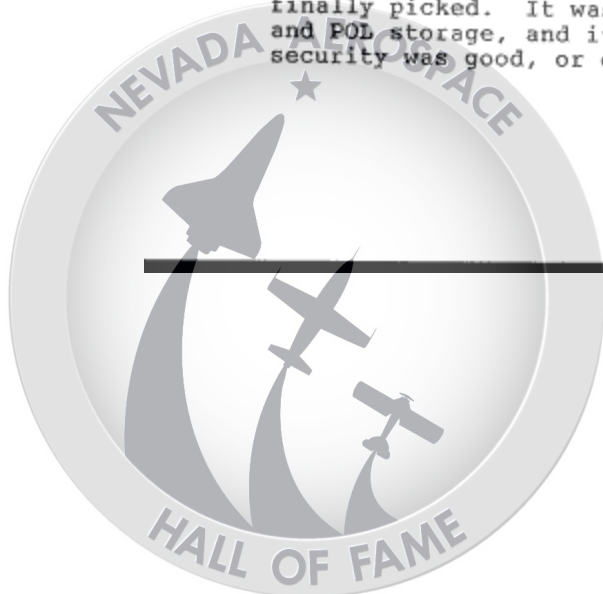


To test the effectiveness of antiradar devices a small-scale model is inadequate; only a full-size mock-up will do. Lockheed accordingly built one of these, and as early as November 1959, transported it in a specially designed trailer truck over hundreds of miles of highway from the Burbank plant to the test area. Here it was hoisted to the top of a pylon and looked at from various angles by radar. Tests and adjustments went on for a year and a half before the results were deemed satisfactory. In the course of the process it was found desirable to attach some sizable metallic constructions on each side of the fuselage, and Kelly Johnson worried a good deal about the effect of these protuberances on his design. In flight tests, however, it later developed that they imparted a useful aerodynamic lift to the vehicle, and years afterward Lockheed's design for a supersonic transport embodied similar structures.

Pilots for the OXCART would obviously have to be of quite extraordinary competence, not only because of the unprecedented performance of the aircraft itself, but also because of the particular qualities needed in men who were to fly intelligence missions. Brigadier General Don Flickinger of the Air Force, was designated to draw up the criteria for selection, with advice from Kelly Johnson and from CIA Headquarters. Pilots had to be qualified in the latest high performance fighters, emotionally stable, and well motivated. They were to be between 25 and 40 years of age, and the size of the A-12 cockpit prescribed that they be under six feet tall and under 175 pounds in weight.

One thing to be decided in the earliest stages of the program was where to base and test the aircraft. Lockheed clearly could not do the business at Burbank, where the aircraft were being built, if for no other reason that its runway was too short. The ideal location ought to be remote from metropolitan areas; well away from civil and military airways to preclude observation; easily accessible by air; blessed with good weather the year round; capable of accommodating large numbers of personnel; equipped with fuel storage facilities; fairly close to an Air Force installation; and possessing at least an 8,000 foot runway. There was no such place to be found.

Ten Air Force bases programmed for closure were considered, but none provided the necessary security and annual operating costs at most of them would be unacceptable. Edwards Air Force Base in California seemed a more likely candidate, but in the end it also was passed over. Instead, a very secluded site was finally picked. It was deficient in personnel accommodations and POD storage, and its long-unused runway was inadequate, but security was good, or could be made so, and a moderate



construction program could provide sufficient facilities. Lockheed estimated what would be needed in such respects as monthly fuel consumption, hangars and shop space, housing for personnel, and runway specifications. Armed with the list of major requirements, Headquarters came up with a construction and engineering plan.

Construction began in earnest in September 1960, and continued on a double-shift schedule until mid-1964. One of the most urgent tasks was to build the runway, which according to initial estimates of A-12 requirements must be 8,500 feet long. The existing asphalt runway was 5,000 feet long and incapable of supporting the weight of the A-12. The new one was built between 7 September and 15 November and involved pouring over 25,000 yards of concrete. Another major problem was to provide some 500,000 gallons of PF-1 aircraft fuel per month. Neither storage facilities nor means of transporting fuel existed. After considering airlift, pipeline, and truck transport, it was decided that the last-named was the most economical, and could be made feasible by resurfacing no more than eighteen miles of highway leading into the base.

Three surplus Navy hangars were obtained, dismantled, and erected on the north side of the base. Over 100 surplus Navy housing buildings were transported to the base and made ready for occupancy. By early 1962 a fuel tank farm was ready, with a capacity of 1,320,000 gallons. Warehousing and shop space was begun and repairs made to older buildings. All this, together with the many other facilities that had to be provided, took a long time to complete. Meanwhile, however, the really essential facilities were ready in time for the forecast delivery date of Aircraft No. 1 in August 1961.

The facilities were ready, but the aircraft were not. Originally promised for delivery at the end of May 1961, the date first slipped to August, largely because of Lockheed's difficulties in procuring and fabricating titanium. Moreover, Pratt & Whitney found unexpectedly great trouble in bringing the J-58 engine up to OXCART requirements. In March 1961, Kelly Johnson notified Headquarters:

"Schedules are in jeopardy on two fronts. One is the assembly of the wing and the other is in satisfactory development of the engine. Our evaluation shows that each of these programs is from three to four months behind the current schedule."



To this Bissell replied:

"I have learned of your expected additional delay in first flight from 30 August to 1 December 1961. This news is extremely shocking on top of our previous slippage from May to August and my understanding as of our meeting 19 December that the titanium extrusion problems were essentially overcome. I trust this is the last of such disappointments short of a severe earthquake in Burbank."

Realizing that delays were causing the cost of the program to soar, Headquarters decided to place a top-level aeronautical engineer in residence at Lockheed to monitor the program and submit progress reports.

Delays nevertheless persisted. On 11 September, Pratt & Whitney informed Lockheed of their continuing difficulties with the J-58 engine in terms of weight, delivery, and performance. Completion date for Aircraft No. 1 by now had slipped to 22 December 1961, and the first flight to 27 February 1962. Even on this last date the J-58 would not be ready, and it was therefore decided that a Pratt & Whitney J-75 engine, designed for the F-105 and flown in the U-2, should be used for early flights. The engine, along with other components, could be fitted to the A-12 airframe, and it could power the aircraft safely to altitudes up to 50,000 feet and at speeds up to Mach 1.6.

When this decision had been made, final preparations were begun for the testing phase. Support aircraft began arriving in the spring of 1962. These included eight F-101's for training, two T-33's for proficiency flying, a C-130 for cargo transport, a U-3A for administrative purposes, a helicopter for search and rescue, and a Cessna-180 for liaison use. In addition, Lockheed provided an F-104 to act as chase aircraft during the A-12 flight test period.

Meanwhile in January 1962, an agreement was reached with the Civil Aeronautics Board that expanded the restricted airspace in the vicinity of the test area. Certain CAB air traffic controllers were cleared for the OXCART Project; their function was to insure that aircraft did not violate the order. The North American Air Defense Command established procedures to prevent their radar stations from reporting the appearance of high performance aircraft on their radar scopes.

Refueling concepts required repositioning of vast quantities of fuel at certain points outside the United States. Special tank farms were programmed in California, Eielson AFB Alaska, and at strategic locations overseas. Since the A-12 used specially refined low vapor pressure fuel, these tank farms



were reserved exclusively for use by the OXCART Program. Very small detachments of technicians at these locations maintained the fuel storage facility and arranged for periodic quality control fuel tests.

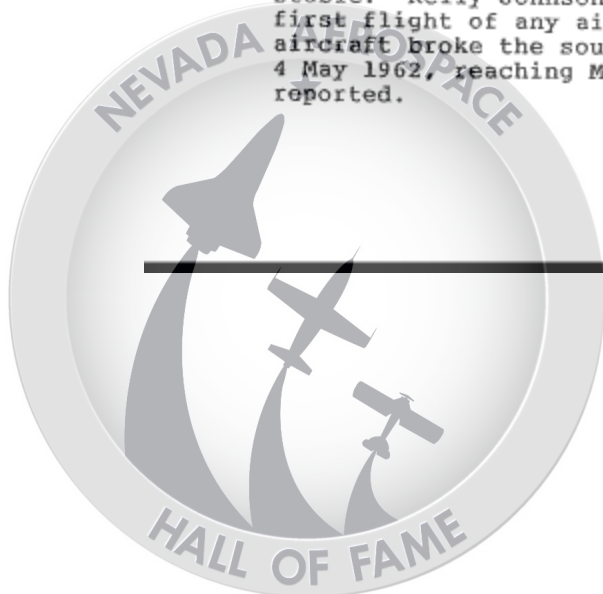
At the Lockheed Burbank plant, Aircraft No. 1 (serially numbered 121) received its final tests and checkout during January and February 1962, and was partially disassembled for shipment to the site. It became clear very early in OXCART planning that because of security problems and the inadequate runway, the A-12 could not fly from Burbank. Movement of the full-scale radar test model had been successfully accomplished in November 1959, as described above. A thorough survey of the route in June 1961, ascertained the hazards and problems of moving the actual aircraft, and showed that a package measuring 35 feet wide and 105 feet long could be transported without major difficulty. Obstructing road signs had to be removed, trees trimmed, and some roadsides leveled. Appropriate arrangements were made with police authorities and local officials to accomplish the safe transport of the aircraft. The entire fuselage, minus wings, was crated, covered, and loaded on the special-design trailer, which cost about \$100,000. On 26 February 1962, it departed Burbank, and arrived at the base according to plan.

First Flights

Upon arrival reassembly of the aircraft and installation of the J-75 engines began. Soon it was found that aircraft tank sealing compounds had failed to adhere to the metals, and when fuel was put into the tanks numerous leaks occurred. It was necessary to strip the tanks of the faulty sealing compounds and reline them with new materials. Thus occurred one more unexpected and exasperating delay in the program.

Finally, on 26 April 1962, Aircraft 121 was ready. On that day, in accordance with Kelly Johnson's custom, Louis Schalk took it for an unofficial, unannounced, maiden flight lasting some 40 minutes. As in all maiden flights minor problems were detected, but it took only four more days to ready the aircraft for its first official flight.

On 30 April 1962, just under one year later than originally planned, the A-12 officially lifted her wheels from the runway. Piloted again by Louis Schalk, it took off at 170 knots, with a gross weight of 72,000 pounds, and climbed to 30,000 feet. Top speed was 340 knots and the flight lasted 59 minutes. The pilot reported that the aircraft responded well and was extremely stable. Kelly Johnson declared it to be the smoothest official first flight of any aircraft he had designed or tested. The aircraft broke the sound barrier on its second official flight, 4 May 1962, reaching Mach 1.1. Again, only minor problems were reported.



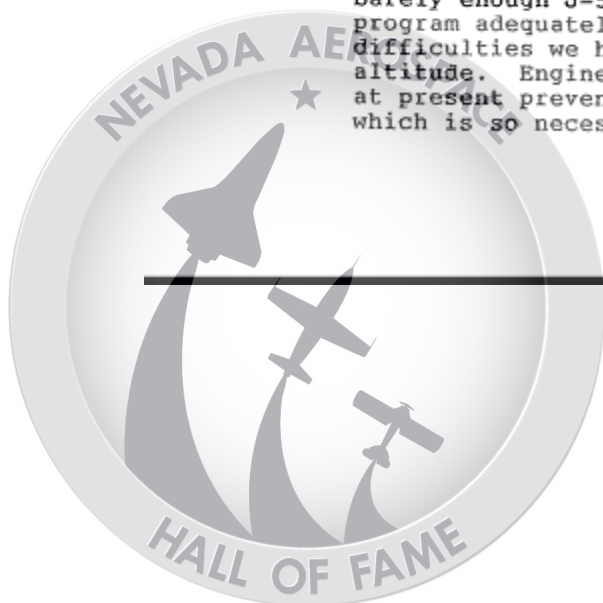
With these flights accomplished, jubilation was the order of the day. The new Director of Central Intelligence, Mr. John McCone, sent a telegram of congratulation to Kelly Johnson. A critical phase had been triumphantly passed, but there remained the long, difficult, and sometimes discouraging process of working the aircraft up to full operational performance.

Aircraft No. 122 arrived at base on 26 June, and spent three months in radar testing before engine installations and final assembly. Aircraft No. 123 arrived in August and flew in October. Aircraft No. 124, a two-seated version intended for use in training project pilots, was delivered in November. It was to be powered by the J-58 engines, but delivery delays and a desire to begin pilot training prompted a decision to install the smaller J-75's. The trainer flew initially in January 1963. The fifth aircraft, No. 125, arrived at the area on 17 December.

Meanwhile the OXCART program received a shot in the arm from the Cuban missile crisis. U-2's had been maintaining a regular reconnaissance vigil over the island, and it was on one of these missions in October that the presence of offensive missiles was discovered. Overflights thereafter became more frequent, but on 27 October a U-2, flown by a Strategic Air Force pilot on a SAC-directed mission, was shot down by a surface-to-air missile. This raised the dismaying possibility that continued manned, high-altitude surveillance of Cuba might become out of the question. The OXCART program suddenly assumed greater significance than ever, and its achievement of operational status became one of the highest national priorities.

At the end of 1962 there were two A-12 aircraft engaged in flight tests. A speed of Mach 2.16 and altitude of 60,000 feet had been achieved. Progress was still slow, however, because of delays in the delivery of engines and shortcomings in the performance of those delivered. One of the two test aircraft was still flying with two J-75 engines, and the other with one J-75 and one J-58. It had long since become clear that Pratt & Whitney had been too optimistic in their forecast; the problem of developing the J-58 up to OXCART specifications had proved a good deal more recalcitrant than expected. Mr. McCone judged the situation to be truly serious, and on 3 December he wrote to the President of United Aircraft Corporation:

"I have been advised that J-58 engine deliveries have been delayed again due to engine control production problems....By the end of the year it appears we will have barely enough J-58 engines to support the flight test program adequately....Furthermore, due to various engine difficulties we have not yet reached design speed and altitude. Engine thrust and fuel consumption deficiencies at present prevent sustained flight at design conditions which is so necessary to complete development."



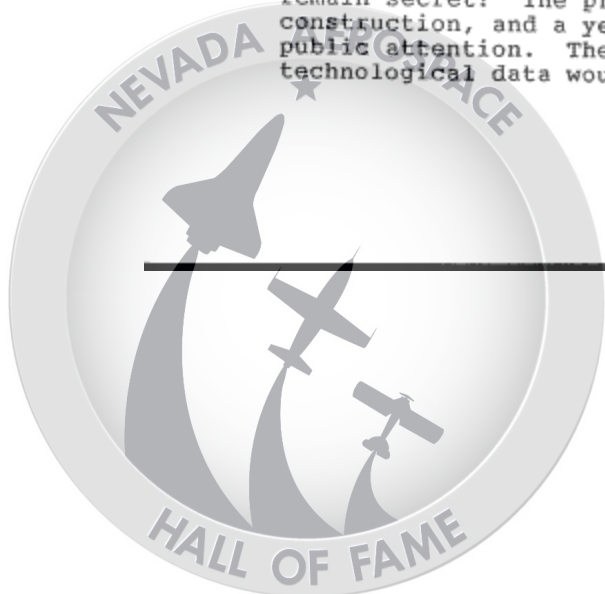
By the end of January 1963, ten engines were available, and the first flight with two of them installed occurred on 15 January. Thenceforth all A-12 aircraft were fitted with their intended propulsion system. Flight testing accelerated and contractor personnel went to a three-shift work day.

With each succeeding step into a high Mach regime new problems presented themselves. The worst of all these difficulties--indeed one of the most formidable in the entire history of the program--was revealed when flight testing moved into speeds between Mach 2.4 and 2.8, and the aircraft experienced such severe roughness as to make its operation virtually out of the question. The trouble was diagnosed as being in the air inlet system, which with its controls admitted air to the engine. At the higher speeds the flow of air was uneven, and the engine therefore could not function properly. Only after a long period of experimentation, often highly frustrating and irritating, was a solution reached. This further postponed the day when the A-12 could be declared operationally ready.

Among more mundane troubles was the discovery that various nuts, bolts, clamps, and other debris of the manufacturing process had not been cleared away, and upon engine run up or take off were sucked into the engine. The engine parts were machined to such close tolerances that they could be ruined in this fashion. Obviously the fault was due to sheer carelessness. Inspection procedures were revised, and it was also found prudent at Burbank to hoist the engine nacelles into the air, rock them back and forth, listen for loose objects, and then remove them by hand.

On 24 May 1963, while on a routine training flight, one of the detachment pilots recognized an erroneous and confusing air speed indication and decided to eject from the aircraft, which crashed 14 miles south of Wendover, Utah. The pilot was unhurt. The wreckage was recovered in two days, and persons at the scene were identified and requested to sign secrecy agreements. All A-12 aircraft were grounded for a week during investigation of the accident. A plugged pilot static tube in icing conditions turned out to be responsible for the faulty cockpit instrument indications--it was not something which would hold things up for long.

Loss of this aircraft nevertheless precipitated a policy problem which had been troubling the Agency for some time. With the growing number of A-12's, how much longer could the project remain secret? The program had gone through development, construction, and a year of flight testing without attracting public attention. There was also a realization that the technological data would be extremely valuable in connection



with feasibility studies for the SST. Finally, there was a growing awareness in the higher reaches of the aircraft industry that something new and remarkable was going on. Rumors spread, and gossip flew about. Commercial airline crews sighted the OXCART in flight. The editor of Aviation Week indicated his knowledge of developments at Burbank. The secrecy was thinning out.

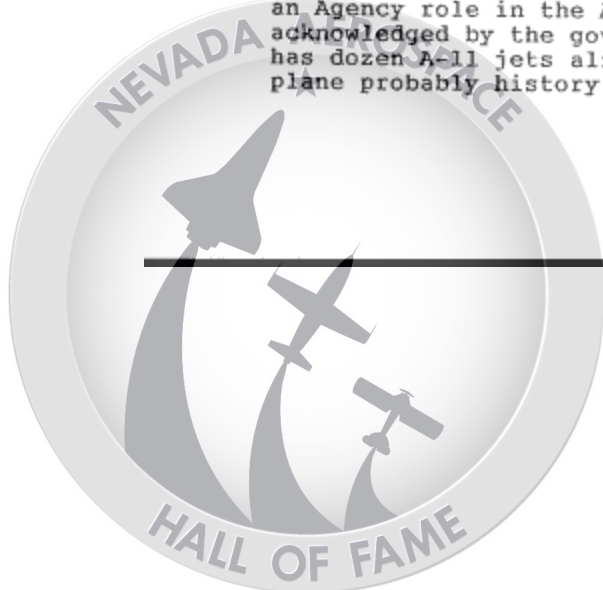
The President's Announcement

In spite of all this, 1963 went by without any public revelation. President Johnson was brought up to date on the project a week after taking office, and directed that a paper be prepared for an announcement in the spring of 1964. Then at his press conference on 24 February 1964, he read a statement of which the first paragraph was as follows:

The United States has successfully developed an advanced experimental jet aircraft, the A-11, which has been tested in sustained flight at more than 2,000 miles per hour and at altitudes in excess of 70,000 feet. The performance of the A-11 far exceeds that of any other aircraft in the world today. The development of this aircraft has been made possible by major advances in aircraft technology of great significance for both military and commercial applications. Several A-11 aircraft are now being flight tested at Edwards Air Force Base in California. The existence of this program is being disclosed today to permit the orderly exploitation of this advance technology in our military and commercial program."

The President went on to mention the "mastery of the metallurgy and fabrication of titanium metal" which has been achieved, gave credit to Lockheed and to Pratt & Whitney, remarked that appropriate members of the Senate and House had been kept fully informed, and prescribed that the detailed performance of the A-11 would be kept strictly classified.

The President's reference to the "A-11" was of course deliberate. "A-11" had been the original design designation for the all-metal aircraft first proposed by Lockheed; subsequently it became the design designation for the Air Force YF-12A interceptor which differed from its parent mainly in that it carried a second man for launching air-to-air missiles. To preserve the distinction between the A-11 and the A-12 Security had briefed practically all witting personnel in government and industry on the impending announcement. OXCART secrecy continued in effect. There was considerable speculation about an Agency role in the A-11 development, but it was never acknowledged by the government. News headlines ranged from "US has dozen A-11 jets already flying" to "Secret of sizzling new plane probably history's best kept."



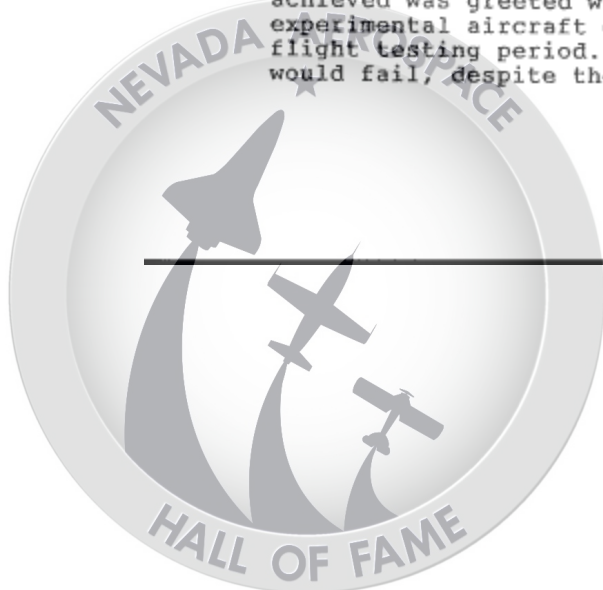
The President also said that "the A-11 aircraft now at Edwards Air Force Base are undergoing extensive tests to determine their capabilities as long-range interceptors." It was true that the Air Force in October 1960, had contracted for three interceptor versions of the A-12, and they were by this time available. But at the moment when the President spoke, there were no A-11's at Edwards and there never had been. Project officials had known that the public announcement was about to be made, but they had not been told exactly when. Caught by surprise, they hastily flew two Air Force YF-12A's to Edwards to support the President's statement. So rushed was this operation, so speedily were the aircraft put into hangars upon arrival, that heat from them activated the hangar sprinkler system, dousing the reception team which awaited them.

Thenceforth, while the OXCART continued its secret career at its own site, the A-11 performed at Edwards Air Force Base in a considerable glare of publicity. Pictures of the aircraft appeared in the press, correspondents could look at it and marvel, stories could be written. Virtually no details were made available, but the technical journals nevertheless had a field day. The unclassified Air Force and Space Digest, for example, published a long article in its issue of April 1964, commencing: "The official pictures and statements tell very little about the A-11. But the technical literature from open sources, when carefully interpreted, tells a good deal about what it could and, more importantly, what it could not be. Here's the story....."

Going Operational

Three years and seven months after first flight in April 1962 the OXCART was declared ready for operational use at design specifications. The period thus devoted to flight tests was remarkably short, considering the new fields of aircraft performance which were being explored. As each higher Mach number was reached exhaustive tests were carried out in accordance with standard procedures to ensure that the aircraft functioned properly and safely. Defects were corrected and improvements made. All concerned gained experience with the particular characteristics and idiosyncrasies of the vehicle.

The aircraft inlet and related control continued for a long time to present the most troublesome and refractory problem. Numerous attempts failed to find a remedy, even though a special task force concentrated on the task. For a time there was something approaching despair, and the solution when finally achieved was greeted with enormous relief. After all, not every experimental aircraft of advanced performance has survived its flight testing period. The possibility existed that OXCART also would fail, despite the great cost and effort expended upon it.



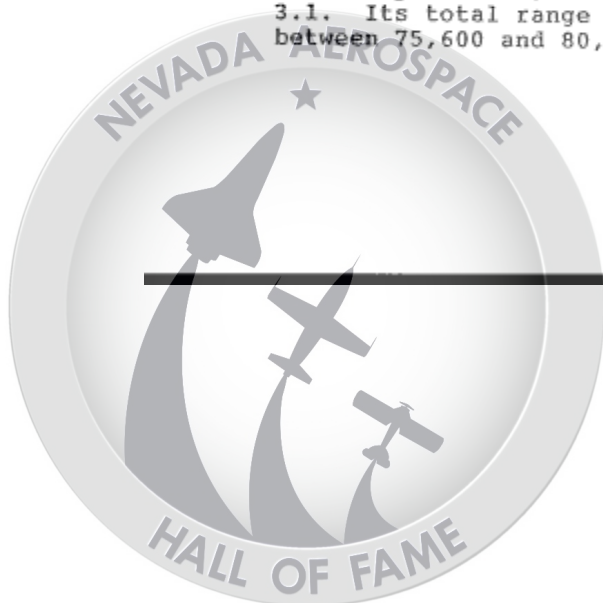
The main burden of test flights fell upon Lockheed pilots, and some of the aircraft that became available at the site were reserved for the most advanced testing. At the same time, however, the detachment pilots were receiving training and familiarizing themselves with the new vehicle. In the course of doing so, they contributed a good many suggestions for improvements, and their own numerous flights shortened the time required for the test program as a whole. Indeed, one feature of OXCART development was this intimate collaboration between designer, test pilots, operational pilots, and CIA officials, all of whom worked together with great effectiveness.

A few dates and figures will serve to mark the progress of events. By the end of 1963 there had been 573 flights totalling 765 hours. Nine aircraft were in the inventory. On 20 July 1963 test aircraft flew for the first time at Mach 3; in November Mach 3.2 (the design speed) was reached. The longest sustained flight at design conditions occurred on 3 February 1964; it lasted for ten minutes at Mach 3.2. By the end of 1964 there had been 1,160 flights, totalling 1,616 hours. Eleven aircraft were then available, four of them reserved for testing and seven assigned to the operational detachment.

The record may be put in another way. Mach 2 was reached after six months of flying; Mach 3 after 15 months. Two years after the first flight the aircraft had flown a total of 38 hours at Mach 2, three hours at Mach 2.6, and less than one hour at Mach 3. After three years, Mach 2 time had increased to 60 hours, Mach 2.6 time to 33 hours, and Mach 3 time to nine hours; all Mach 3 time, however, was by test aircraft, and detachment aircraft were still restricted to Mach 2.9.

As may be seen from the figures, most flights were of short duration, averaging little more than an hour each. Primarily this was because longer flights were unnecessary at this stage of testing. It was also true, however, that the less seen of OXCART the better, and short flights helped to preserve the secrecy of the proceedings. Yet it was virtually impossible for an aircraft of such dimensions and capabilities to remain inconspicuous. At its full speed OXCART had a turning radius of no less than 86 miles. There was no question of staying close to the airfield; its shortest possible flights took it over a very large expanse of territory.

The first long-range, high-speed flight occurred on 27 January 1965, when one of the test aircraft flew for an hour and forty minutes, with an hour and fifteen minutes above Mach 3.1. Its total range was 2,580 nautical miles, with altitudes between 75,600 and 80,000 feet.



Two more aircraft were lost during this phase of the program. On 9 July 1964 Aircraft No. 133 was making its final approach to the runway when at altitude of 500 feet and airspeed of 200 knots it began a smooth steady roll to the left. Lockheed test pilot Bill Parks could not overcome the roll. At about a 45 degree bank angle and 200 foot altitude he ejected. As he swung down to the vertical in the parachute his feet, touched the ground, for what must have been one of the narrower escapes in the perilous history of test piloting. The primary cause of the accident was that the servo for the right outboard roll and pitch control froze. No news of the accident filtered out.

On 28 December 1965 Aircraft No. 126 crashed immediately after take-off and was totally destroyed. The detachment pilot ejected safely at an altitude of 150 feet. The accident investigation board determined that a flight line electrician had improperly connected the yaw and pitch gyros--had in effect reversed the controls. This time Mr. McCone directed the Office of Security to conduct an investigation into the possibility of sabotage. While nothing of the sort was discovered, there were indications of negligence, as the manufacturer of the gyro had earlier warned of the possibility that the mechanism could be connected in reverse. No action had been taken, however, even by such an elementary precaution as painting the contacts different colors. Again there was no publicity connected with the accident.

The year 1965 saw the test site reach the high point of activity. Completion of construction brought it to full physical size. All detachment pilots were Mach 3.0 qualified. Site population reached over 1,800. Contractors were working three shifts a day. Lockheed Constellations made daily flights between the factory at Burbank and the site. And officials were considering how and when and where to use OXCART in its appointed role.

Targeting the OX

By early 1964 Project Headquarters began planning for the contingency of flights over Cuba under a program designated SKYLARK. Bill Parks' accident in early July held this program up for a time, but on 5 August it was directed that SKYLARK achieve emergency operational readiness by 5 November. This involved preparing a small detachment which should be able to do the job over Cuba, though at something less than the full design capability of the OXCART. The goal was to operate at Mach 2.8 and 80,000 feet altitude.



In order to meet the deadline set, camera performance would have to be validated, pilots qualified for Mach 2.8 flight, and coordination with supporting elements arranged. Only one of several equipments for electronic countermeasures (ECM) would be ready by November, and a senior intra-governmental group, including representation from the President's Scientific Advisor Committee, examined the problem of operating over Cuba without the full complement of defensive systems. This panel decided that the first few overflights could safely be conducted without them, but the ECM would be necessary thereafter. The delivery schedule of ECM equipment was compatible with this course of action.

After considerable modifications to aircraft, the detachment simulated Cuban missions on training flights, and a limited emergency SKYLARK capability was announced. With two weeks notice the OXCART detachment could accomplish a Cuban overflight, though with fewer ready aircraft and pilots than had been planned.

During the following weeks the detachment concentrated on developing SKYLARK into a sustained capability, with five ready pilots and five operational aircraft. The main tasks were to determine aircraft range and fuel consumption, attain repeatable reliable operation, finish pilot training, prepare a family of SKYLARK missions, and coordinate routes with North American Air Defense, Continental Air Defense, and the Federal Aviation Authority. All this was accomplished without substantially hindering the main task of working up OXCART to full design capability. We may anticipate the story, however, by remarking that despite all this preparation the OXCART was never used over Cuba. U-2's proved adequate, and the A-12 was reserved for more critical situations.

In 1965 a more critical situation did indeed emerge in Asia, and interest in using the aircraft there began to be manifest. The Director of the Office of Special Activities briefed senior officials on a scheme which had been drawn up for operations in the Far East. The project was called BLACK SHIELD, and it called for the OXCART to operate out of the Kadena Air Force Base in Okinawa. In the first phase, three aircraft would stage to Okinawa for 60-day periods, twice a year, with about 225 personnel involved. After this was in good order, BLACK SHIELD would advance to the point of maintaining a permanent detachment at Kadena. Secretary Vance made \$3.7 million available to be spent in providing support facilities on the island, which were to be available by early fall of 1965.



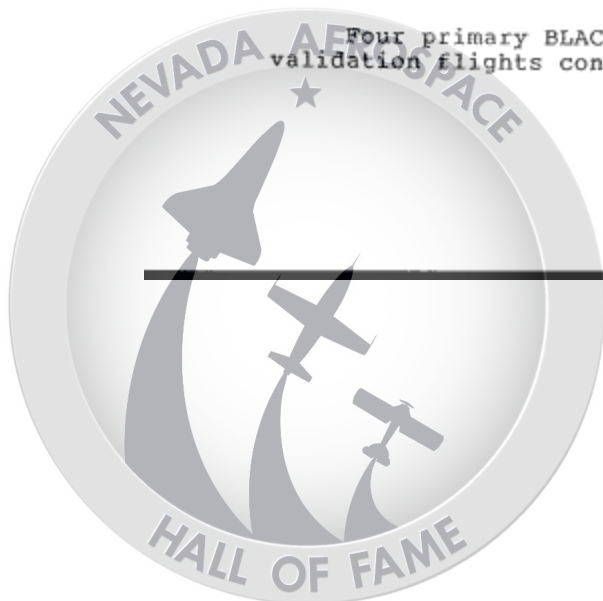
Meanwhile the Communists began to deploy surface-to-air missiles around Hanoi, thereby threatening our current military reconnaissance capabilities. Secretary McNamara called this to the attention of the Under Secretary of the Air Force on 3 June 1965, and inquired about the practicability of substituting OXCART aircraft for U-2's. He was told that BLACK SHIELD could operate over Vietnam as soon as adequate aircraft performance was achieved.

With deployment overseas thus apparently impending in the fall, the detachment went into the final stages of its program for validating the reliability of aircraft and aircraft systems. It set out to demonstrate complete systems reliability at Mach 3.05 and at 2,300 nautical miles range, with penetration altitude of 76,000 feet. A demonstrated capability for three aerial refuelings was also part of the validation process.

By this time the OXCART was well along in performance. The inlet, camera, hydraulic, navigation, and flight control systems all demonstrated acceptable reliability. Nevertheless, as longer flights were conducted at high speeds and high temperatures, new problems came to the surface, the most serious being with the electrical wiring system. Wiring connectors and components had to withstand temperatures of more than 800 degrees Fahrenheit, together with structural flexing, vibration, and shock. Continuing malfunctions in the inlet controls, communications equipment, ECM systems, and cockpit instruments were in many cases attributable to wiring failures. There was also disturbing evidence that careless handling was contributing to electrical connector failures. Difficulties persisted in the sealing of fuel tanks. What with one thing and another, officials soon began to fear that the scheduled date for BLACK SHIELD readiness would not be met. Prompt corrective action on the part of Lockheed was in order. The quality of maintenance needed drastic improvement. The responsibility for delivering an aircraft system with acceptable reliability to meet an operational commitment lay in Lockheed's hands.

In this uncomfortable situation, OSA's Deputy for Technology went to the Lockheed plant to see Kelly Johnson on 3 August 1965. A frank discussion ensued on the measures necessary to insure that BLACK SHIELD commitments would be met, and Johnson concluded that he himself spend full time at the site in order to get the job done expeditiously. Lockheed President Daniel Haughton offered the full support of the corporation, and Johnson began duty at the site next day. His firm and effective management got Project BLACK SHIELD back on schedule.

Four primary BLACK SHIELD aircraft were selected and final validation flights conducted. During these tests the OXCART



achieved a maximum speed of Mach 3.29, altitude of 90,000 feet, and sustained flight time above Mach 3.2 of one hour and fourteen minutes. The maximum endurance flight lasted six hours and twenty minutes. The last stage was reached on 20 November 1965, and two days later Kelly Johnson wrote Headquarters:

"Overall, my considered opinion is that the aircraft can be successfully deployed for the BLACK SHIELD mission with what I would consider to be at least as low a degree of risk as in the early U-2 deployment days. Actually, considering our performance level of more than four times the U-2 speed and three miles more operating altitude, it is probably much less risky than our first U-2 deployments. I think the time has come when the bird should leave its nest."

An impressive demonstration of the OXCART's capability occurred on 21 December 1966 when Lockheed test pilot Bill Parks flew 10,198 statute miles in six hours. This flight established a record unapproachable by any other aircraft.

With the readiness of the aircraft confirmed, a formal proposal was made that OXCART be deployed to the Far East. After examining the matter, the proposal was not approved. It was agreed, however, that short of actually moving aircraft to Kadana all steps should be taken to develop and maintain a quick reaction capability, ready to deploy within a 21-day period at any time after 1 January 1966. There the matter remained, for more than a year. During 1966 there were frequent renewals of the request for authorization to deploy OXCART to Okinawa and conduct reconnaissance missions over North Vietnam. All were turned down.

Meanwhile, of course, flight testing and crew proficiency training continued. There was plenty of time to improve mission plans and flight tactics, as well as to prepare the forward area at Kadana. New plans shortened deployment time from the 21 days first specified. Personnel and cargo were to be airlifted to Kadana the day deployment was approved. On the fifth day the first OXCART would depart and travel the 6,673 miles in five hours and 34 minutes. The second would go on the seventh and third on the ninth day. The first two would be ready for an emergency mission on the eleventh day, and for a normal mission on the fifteenth day.

BLACK SHIELD

About May of 1967 prospects for deployment took a new turn. A good deal of apprehension was evident in Washington about the possibility that the Communists might introduce surface-to-surface missiles into North Vietnam, and concern was aggravated by doubts as to whether we could detect such a



development if it occurred. The President asked for a proposal on the matter and once again CIA suggested that the OXCART be used. Its camera was far superior to the U-2 and its vulnerability was far less. The State and Defense members of the Committee decided to re-examine the requirement and the political risks involved. While they were engaged in their deliberations, the Director of Central Intelligence, Mr. Helms, submitted another formal proposal to deploy the OXCART. In addition, he raised the matter at President Johnson's "Tuesday lunch" on 16 May, and received the President's approval to "go." Walt Rostow later in the day formally conveyed the President's decision, and the BLACK SHIELD deployment plan was forthwith put into effect.

On 17 May airlift to Kadena began. On 22 May the first A-12 (Serial No. 131) flew nonstop to Kadena in six hours and six minutes. Aircraft No. 127 departed on 24 May and arrived at Kadena five hours and 55 minutes later. The third, No. 129, left according to plan on 26 May 1967 and proceeded normally until in the vicinity of Wake Island the pilot experienced difficulties with the inertial navigation and communications systems. Under the circumstances, he decided to make a precautionary landing at Wake Island. The prepositioned emergency recovery team secured the aircraft without incident and the flight to Kadena resumed next day.

On 29 May 1967, the unit at Kadena was ready to fly an operational mission. Two hundred and sixty personnel had deployed to the BLACK SHIELD facility. Except for hangars, which were a month short of completion, everything was in shape for sustained operations. Next day the detachment was alerted for a mission on 31 May, and the moment arrived which would see the culmination of ten years of effort, worry, and cost. As fate would have it, on the morning of the 31st heavy rain fell at Kadena. Since weather over the target area was clear, preparations continued in hopes that the local weather would clear. When the time for take-off approached, the OXCART, which had never operated in heavy rain, taxied to the runway, and took off while the rain continued.

The first BLACK SHIELD mission followed one flight line over North Vietnam and one over the Demilitarized Zone. It lasted three hours and 39 minutes, and the cruise legs were flown at Mach 3.1. Results were satisfactory. Seventy of the 190 known SAM sites in North Vietnam were photographed, as were nine other priority targets. There were no radar signals detected, indicating that the first mission had gone completely unnoticed.



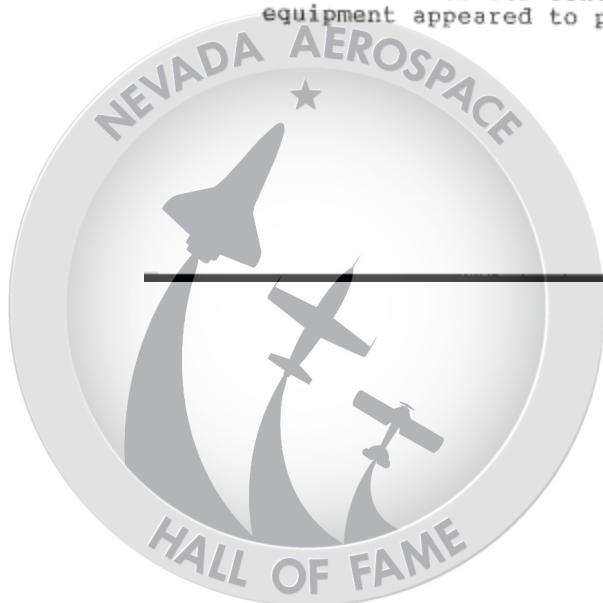
Fifteen BLACK SHIELD missions were alerted during the period from 31 May to 15 August 1967. Seven of the fifteen were flown and of these four detected radar tracking signals, but no hostile action was taken against any of them. By mid-July it had been determined with a high degree of confidence that there were no surface-to-surface missiles in North Vietnam.

Operations and maintenance at Kadena began with the receipt of alert notification. Both a primary aircraft and pilot and a backup aircraft and pilot were selected. The aircraft were given thorough inspection and servicing, all systems were checked, and the cameras loaded into the aircraft. Pilots received a detailed route briefing in the early evening prior to the day of flight. On the morning of the flight a final briefing occurred, at which time the condition of the aircraft and its systems was reported, last-minute weather forecasts reviewed, and other relevant intelligence communicated, together with any amendments or changes in the flight plan. Two hours prior to take-off the primary pilot had a medical examination, got into his suit, and was taken to the aircraft. If any malfunctions developed on the primary aircraft, the back-up could execute the mission one hour later.

A typical route profile for a BLACK SHIELD mission over North Vietnam included a refueling shortly after takeoff, south of Okinawa, the planned photographic pass or passes, withdrawal to a second aerial refueling in the Thailand area, and return to Kadena. So great was the OXCART's speed that it spent only 12 1/2 minutes over North Vietnam in a typical "single pass" mission, or a total of 21 1/2 minutes on two passes.

Once landed back at Kadena, the camera film was removed from the aircraft, boxed, and sent by special plane to the processing facilities. By late summer an Air Force Center in Japan carried out the processing in order to place the photointelligence in the hands of American commanders in Vietnam within 24 hours of completion of a BLACK SHIELD mission.

Between 16 August and 31 December 1967, twenty-six missions were alerted. Fifteen were flown. On 17 September one SAM site traced the vehicle with its acquisition radar but was unsuccessful with its Fan Song guidance radar. On 28 October a North Vietnamese SAM site for the first time launched a single, albeit unsuccessful, missile at the OXCART. Photography from this mission documented the event with photographs of missile smoke above the SAM firing site, and with pictures of the missile and of its contrail. Electronic countermeasures equipment appeared to perform well against the missile firing.



During the flight of 30 October 1967, two sites prepared to launch missiles but neither did. During the second pass at least six missiles were fired at the OXCART, each confirmed by missile vapor trails on mission photography. The pilot saw these vapor trails and witnessed three missile detonations. Post-flight inspection of the aircraft revealed that a piece of metal had penetrated the lower right wing fillet area and lodged against the support structure of the wing tank. The fragment was not a warhead pellet but may have been a part of the debris from one of the missile detonations observed by the pilot.

The SR-71

In late 1962, the Air Force ordered a fleet of A-11's from Lockheed, which upon being finished as two-seated reconnaissance aircraft would be named SR-71. The first flight was made in December 1964 and the SR-71 became operation in 1967. The fact that these aircraft were ordered eased the path of OXCART development, since it meant that the financial burden was shared with the Air Force, and the cost per aircraft was somewhat reduced by producing greater numbers. In the longer run, however, the existence of SR-71 spelled the doom of OXCART.

Ending

In spite of all the efforts to save the program, the Secretary of Defense on 16 May 1968 reaffirmed the original decision to terminate the OXCART Program and store the aircraft. This decision was confirmed by the President on 21 May 1968 during his weekly luncheon meeting with his principal advisers.

Early in March 1968, USAF SR-71 aircraft began to arrive at Kadena to take over the BLACK SHIELD commitment, and by gradual stages the A-12 was placed on standby to back up the SR-71. Project Headquarters selected 8 June 1968 as the earliest possible date to begin redeployment, and in the meantime flights of A-12 aircraft were to be limited to those essential for maintaining flying safety and pilot proficiency. After BLACK SHIELD aircraft arrived in the US they would proceed to storage. Those already at base were placed in storage by 7 June.

Postscript

In summary: the OXCART Program lasted just over ten years, from its inception in 1957 through first flights in 1962 to termination in 1968. During this period a total of 22 operational missions had been flown over hostile territory.



Lockheed produced 15 OXCARTS, three YF-12-A's, and 31 SR-71's. Five OXCARTs were lost in accidents; two pilots were killed, and two had narrow escapes. In addition, two F-101 chase planes were lost with their Air Force pilots during OXCART's testing phase.

The main objective of the program--to create a reconnaissance aircraft of unprecedented speed, range, and altitude capability--was triumphantly achieved. It may well be, however, that the most important aspects of the effort lay in its by-products--the notable advances in aerodynamic design, engine performance, cameras, electronic countermeasures, pilot life support systems, antiradar devices, and above all in milling, machining, and shaping titanium. Altogether it was a pioneering accomplishment.



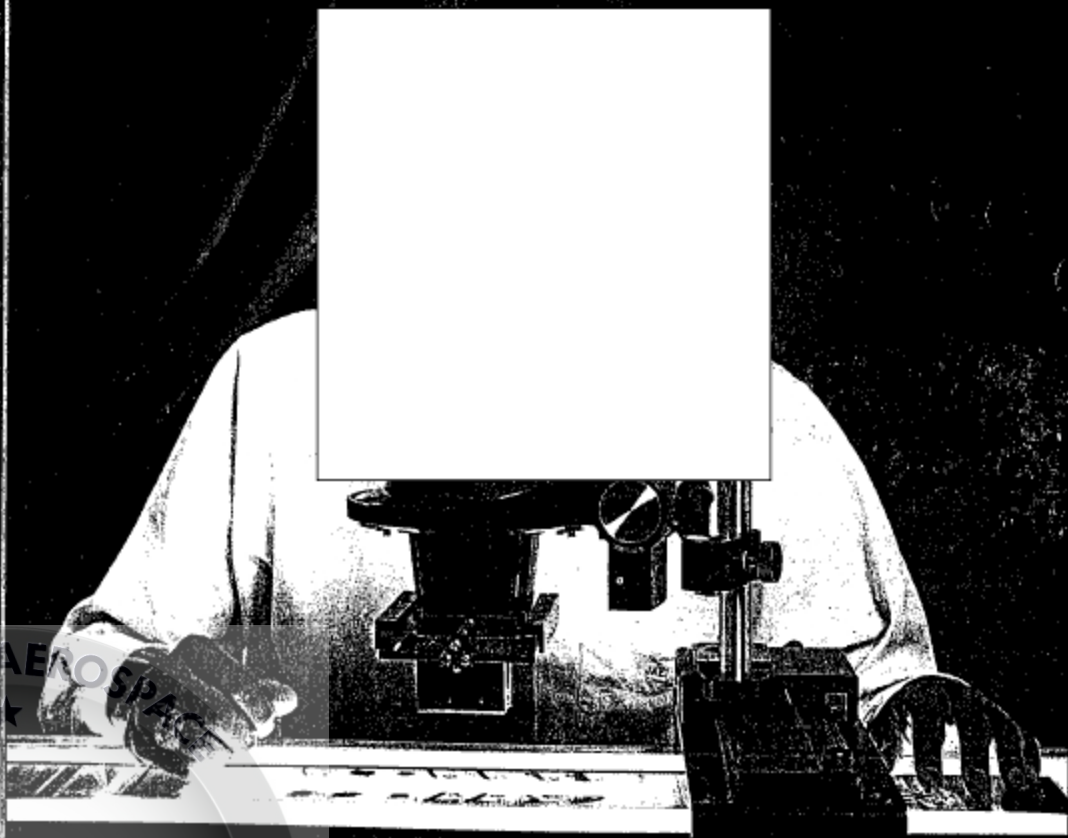
Title:	(EST PUB DATE) THIRTY . . . AND THRIVING
Abstract:	
Pages:	0024
Pub Date:	12/1/1991
Release Date:	4/12/2002
Keywords:	TECHNOLOGY COLD WAR NPIC TREATIES IMAGERY ANALYSIS NSCID
Case Number:	F-2002-00303
Copyright:	0
Release Decision:	RIPPUB
Classification:	U



THIRTY AND THRIVING

"Discoveries are made by some individual who has freed himself from a way of thinking that is held by friends and associates who may be more intelligent, better educated, [and] better disciplined, but who have not mastered the art of a fresh, clean look at the old, old, knowledge."

*-Dr. Edwin H. Land
Eminent Photo Scientist*



We dedicate this publication to the men and women of NPIC—both past and present—who have devoted their lives' work to mastering the art of the "fresh look." As we celebrate 30 years of achievement, we look forward to new ventures and new discoveries.

NEVADA AEROSPACE

HALL OF FAME

and 30th Anniversary

Central Intelligence Agency



Washington, D.C. 20505

18 November 1991

TO THE MEN AND WOMEN OF NPIC:

For the past three decades, NPIC has been a vital part of the Intelligence Community, and, since 1973, a valued office of the Directorate of Science and Technology. During those years, NPIC employees and "alumni" have distinguished themselves as an organization of great vision, broad intellect, and spirited innovation.

Often, when we think of an organization like NPIC, we think in terms of technology. Indeed, today NPIC can boast of some of the most advanced technological tools in the world, tools that allow you to receive, interpret, and report upon imagery-derived findings more efficiently than ever before. But the true measure of an organization does not reside with tools or technology; it resides with individuals. Each member of the NPIC team is a valuable resource; through your efforts, the DS&T and the CIA have met many critical challenges in the past. With your continued energy and enthusiasm, we will meet the tests of the future.

I congratulate each of you for your contributions, and I offer my best wishes for continued successes.

Sincerely,

James V. Hirsch
James V. Hirsch
Deputy Director for Science
and Technology

These and other letters of congratulations will be on display in the Lundahl Room during Open House.



NATIONAL PHOTOGRAPHIC INTERPRETATION CENTER

20 November 1991

TO THE MEN AND WOMEN OF NPIC:

It is a distinct pleasure for me to join with you in commemorating the thirtieth anniversary of the founding of the National Photographic Interpretation Center.

Before coming to NPIC, I was well aware of the Center's long history of significant contributions to our nation's intelligence effort. What has struck me most since my arrival in February 1991, however, is the camaraderie and teamwork displayed by all members of the NPIC community. The men and women of NPIC are truly a community of professionals who share common concerns and interests and who take great pride in their many accomplishments. This professional pride is clearly reflected in the quality of our products and in our responsiveness to the Center's many customers.

Anniversaries are often limited to recollections of past glories. I believe that even as we reflect on our many past achievements—ranging from the Cuban missile crisis through Operations Desert Shield and Desert Storm—we must also look to the future. The competition with the Soviet Union that has dominated US national security policy since World War II is being replaced by a new—and still largely undefined—set of policy problems. We must adapt to this changing policy agenda by providing accurate and timely intelligence that will help our customers—all-source analysts, military commanders, and policymakers—understand rapidly moving events. Given the skill, motivation, and dedication of the NPIC workforce, I am confident that the Center will successfully meet the many and varied intelligence challenges of the future.

I am honored to be part of this extraordinary organization, and I want to thank each of you for your unique and continuing contribution to our mission.

Sincerely,

Leo Mezlewood
Leo Mezlewood
Director

We have assembled this special publication to commemorate NPIC's 30th anniversary. We ask that it not be disseminated beyond NPIC employees and their immediate families.

NEVADA

HALL OF FAME

IMAGERY ANALYSIS IS A PROCESS OF DISCOVERY. IT is the art of obtaining knowledge through search, through study, and through observation. But discovery is not smooth and systematic. It is filled with peaks and valleys; it is subject to false turns and miraculous findings.

The history of NPIC is, in many respects, like the process of discovery. If NPIC's development from 1961 to the present was tracked on a timeline, that line would not be a straightly drawn continuum. Instead, the line would bend and curve, growing more pronounced with the passage of time.

This year, NPIC celebrates the 30th anniversary of National Security Council Intelligence Directive (NSCID) 8, our founding charter. This occasion presents a unique opportunity to follow the NPIC timeline, as it moves past decades and dilemmas on its way to the future. The journey provides some breath-taking images.

We begin at the "official" beginning: 1961.*

The 1960s: Cold War Concerns

The new decade started on a note that was at once hopeful and ominous. John F. Kennedy had been elected President of the United States (the youngest man ever to win that office), but the nation was reeling from the shootdown of the mysterious U-2 spy plane piloted by Gary Francis Powers. That incident exposed the entire photoreconnaissance program to international scrutiny and further ignited Cold War tensions between the US and its principal adversary, the Soviet Union.

Cold War anxieties led to the formation of a special joint-service study, led by Lyman Kirkpatrick (then CIA Inspector General), which assessed the strengths and weaknesses of the US Intelligence Community (IC). The group issued more than 20 specific recommendations, one of which called for the formation of a national interpretation center.

On 18 January 1961, just days before he was to leave office, President Eisenhower signed NSCID 8, which effectively established NPIC. The new National Center was to remain under the administrative management of the CIA, and Arthur C. Lundahl would continue on as Director, with Colonel David A. Parker, USA, serving as Deputy. NPIC, which had grown out of a small division in the CIA's Directorate of Intelligence (DI), was to be a common facility for conducting preliminary, second-, and third-phase exploitation.

Later that year, in another important IC restructuring, the Department of Defense

(DoD) formally established the Defense Intelligence Agency (DIA). Some of its personnel were assigned to NPIC and were integrated with CIA personnel.

For millions of Americans, 1962 will be remembered as the year the US and the Soviet Union almost went to war. Months of U-2 coverage of Cuba indicated a Soviet buildup of military equipment. In mid-October, NPIC photointerpreters (PIs) identified both medium- and intermediate-range missile launch sites. NPIC PIs worked around the clock to keep President Kennedy abreast of the situation. On 22 October, President Kennedy

The 1970s: Technology and Treaties

In 1971, NPIC entered the high-tech realm in several ways; among them: the first high-precision stereocomparator was installed in Building 213, allowing for more detailed measurements.

Meanwhile, NPIC continued to focus on Vietnam, Laos, and Cambodia. Arms control issues also gained prominence, specifically in regard to the Strategic Arms Limitation Treaty (SALT) of 1972.

In 1973, Arthur C. Lundahl retired in June, following 20 years of distinguished service and pioneering photointelligence efforts.

He was replaced by John J. Hicks. In the same year, NPIC left the DI to become an office in the Directorate of Science and Technology (DS&T).

Beyond organizational change, NPIC officers were faced with international change, as Salvador Allende's government was overthrown in Chile, as a Vietnam peace agreement was reached in Paris, and as the October War raged in the Middle East. After the conclusion of the Middle East war, the peace agreement remained an area of concern.

By the mid-1970s, steady increases in the quality and quantity of photointelligence required NPIC PIs to adopt new ways of doing business. Under the direction of John Hicks, NPIC officers underwent a subtle change in role, evolving from PIs who provided quick "reads" to imagery analysts (IAs) who

became full participants in analytical exchanges across the Community.

The end of the Vietnam War generated national concern over the status of prisoners of war and those missing in action; at NPIC, it also generated concern of a different sort. In May 1975, the US container ship *Mayaguez* was seized by a Cambodian gunboat in the Gulf of Siam. President Gerald R. Ford ordered aerial reconnaissance of the area, and NPIC participated fully in the exploitation. After Navy and Marine intervention, the *Mayaguez* was recovered.

In 1976, the year of Mao Tse-tung's death and of a catastrophic earthquake in China, NPIC itself was undergoing historic change. A cadre of analysts and support personnel were transferred to an offsite location to form the nucleus of the Priority Exploitation Group.

NPIC launched its Basic Imagery Analysis School in 1978. The first class consisted of 10 members. Now known as the National Imagery Analysis Course (or NIAC), the program has grown in scope and, in the mid-1980s, gained academic accreditation.

In June of 1978, Rutledge P. "Hap" Hazard replaced John Hicks as Director of NPIC. The Hazard era, like the Hicks and Lundahl

Fresh Looks and First Images

announced a blockade of Cuba. The next day, approximately 15 ships were turned back and sea deliveries came to an end. Subsequent photointelligence indicated that medium-range missiles and bombers, along with support equipment and personnel, had been removed. NPIC's laudatory performance was recognized by President Kennedy.

On 1 January 1963, NPIC moved into Building 213 of the Washington Navy Yard. In November, President Kennedy was assassinated in Dallas, and NPIC participated in the analysis of the infamous Zapruder motion picture of the shooting.

By 1964, NPIC, like much of the nation, began to focus with greater intensity on events in Southeast Asia, particularly in the Gulf of Tonkin. By the middle of the decade, the detonation of the first atomic bomb in China and Israel's Six-Day War also commanded NPIC's attention.

NPIC PIs spent 1968 assessing rapidly unfolding international events in countries such as Vietnam, the Soviet Union, Czechoslovakia, and North Korea. Also during that year, NPIC formed a new group, the Imagery Exploitation Group (IEG), devoted to second-phase exploitation. It would grow to become NPIC's largest component.

* For details on NPIC's pre-1961 history, see "Conversations With Two Former Directors," page 6.

eras before it, was marked by sweeping technological and political change. Hazzard was faced with a daunting challenge: updating NPIC's exploitation technology to accommodate new and highly advanced overhead systems. These efforts came to be known as the NPIC modernization program.

At the same time, NPIC employees were suffering from chronic floorspace inadequacies. Although a three-story addition had been planned, Hazzard recognized that it would not be large enough to house the rapidly growing computer and communications infrastructure. With the support and funding of the US Army, he approved plans to construct a six-story addition. Ground-breaking was held in 1982.

By 1979, a new acronym had been added to NPIC lexicon: INS, which stood for the Improved NPIC System. The INS represented NPIC's entry into a new frontier of computing capability.

Several ominous developments also occurred in 1979: the Shah of Iran was overthrown, Americans were held hostage in the US Embassy in Tehran, and the Soviets invaded Afghanistan. These events stood as precursors of the decade of terrorism, resurgent Muslim fundamentalism, and war that

was to follow. NPIC studied each development closely.

By decade's end, NPIC analysts also were tasked with reporting on activities related to the unratified SALT agreement.

The 1980s: New Mandates

The nation's attention—and compassion—remained focused on Tehran, where American hostages continued to be held. But exploitation resources were dispersed across the globe, as NPIC analysts assessed the conflict between Iran and Iraq and unrest in El Salvador, Poland, Angola, Chad, and Egypt—where President Anwar Sadat was assassinated in 1980.

By the early 1980s, the NPIC modernization program had become the predominant item in the DS&T budget. A new NPIC group, known as the Development Programs Group (DPG), was formed to help direct the planning. In July 1982, the Support Group was formed from what previously had been a Support Staff.

Terrorism, either in the Third World, in Central America, in Ireland, or in the Middle East dominated newspaper headlines during this time. Arms control talks, both for strategic arms and intermediate-range nuclear

forces, consumed NPIC's analytical attention. And, in 1983, NPIC appraised developments in Grenada, where US troops were deployed during Operation Urgent Fury.

In 1984, R.M. Huffstutler, a DI analyst and manager and an economist by training, became NPIC's fourth director, succeeding Hap Hazzard. Under Huffstutler's leadership, the Center experienced dramatic "growth spurts" in terms of technology and people. By June, the addition to Building 213 had been completed.

To use NPIC resources more effectively, Huffstutler divided the unwieldy Operations Support Group into two separate groups: the Exploitation Support Group, which would manage production, processing, and mensuration services; and the Operations and Engineering Group, which would manage and support computer operations.

In 1986, the modernization program reached a dramatic milestone: initial switchover to a powerful new Unisys mainframe computer. Throughout the 1980s, NPIC benefited from further technological enhancements (see "The March of Technology," page 12).

While these advances continued at NPIC, terrorist attacks continued abroad, and



Amazing Journeys

The U-2 began as a rough concept in the "Skunkworks" of Lockheed Aircraft in the 1950s. Since then, it has been the workhorse of reconnaissance.



On the Brink

Overhead images of Cuba in October 1962—like this missile-ready checkout tent—have been etched into the nation's memory. These images also are an indelible part of NPIC's history.



Exploitation Artifacts

Yesterday's clunky mechanical calculators have been outstripped in speed and performance by today's high-powered computers. Yet in the mid-

NEVADA AEROSPACE

HALL OF FAME

reas such as Libya and Lebanon command- intelligence resources. For a period, these vents paled in comparison to the tragedy and devastation of the Chernobyl nuclear disaster. NPIC aided in Community analysis of these events.

In 1987, a new NPIC group, the National Exploitation Laboratory, was formed to serve as a community resource for developing and testing emerging exploitation technologies.

Hostilities in the Middle East and arms control negotiations continued in 1988, as L.M. Huffstutler was reassigned and Frank J. Ruocco took over the directorship. With the Ruocco administration came renewed emphasis on product evaluation, enhanced customer service, and career development. Late in 1988, a new NPIC component, the Imagery Studies Group, was formed. In December, Pan Am flight 103 fell from the sky over Lockerbie, Scotland—victim of a terrorist bomb.

In 1989, the year of the Tiananmen square demonstrations, the National Center was an active analytical player in Operation Just Cause in Panama, in addition to providing vigilant analysis of the Soviet Union's withdrawal from Afghanistan. Arms control continued to be big business, as NPIC sup-

ported both the strategic arms and conventional armed forces treaties. At year's end, the world watched as the Berlin Wall crumbled; in 1990, the two Germanys were reunified.

The 1990s: New World Order

As the new decade started, the National Center, like much of the federal government, began to feel the squeeze of resource reductions. In 1990, after years of growth, development, and investment, the modernization program was brought to a successful close, and DPG was disbanded.

Efforts to strengthen the working relationships between NPIC and its DoD counterparts stood the Center in good stead by the end of 1990, when Iraq's invasion of Kuwait made US military involvement in the Middle East all but inevitable. From the start, NPIC played a strong supporting role.

Frank Ruocco left NPIC in January 1991, just days after the US went to war with Iraq. When Leo Hazlewood, NPIC's sixth director, came on board in mid-February, he found the National Center operating at wartime intensity. After Desert Storm's successful conclusion, the Center received letters of commendation from President George Bush,

General Norman Schwarzkopf, and the Deputy Director of Central Intelligence Richard Kerr. Eleven NPIC components received meritorious unit citations; NPIC received a joint National Intelligence Meritorious Unit Citation, and more than 600 employees received commemorative awards.

The passing year has been one of enormous global change. The new world order in the Middle East is still unclear, as is the state of the Soviet Union following an abortive coup attempt in August. The situation is equally nebulous in other parts of the world, from Eastern Europe to Haiti, from Liberia to Pakistan.

Although international developments in the coming years will be far from predictable, this much remains true: the men and women of NPIC will continue to make contributions to history. □



Fervor and Fury ◉

During the 1970s and 1980s, Islamic fundamentalism affected many points on the globe, including South Africa, where this mass protest was held.



Burning Sands ◉

The burning Kuwaiti oilfields serve as a malevolent backdrop to the Persian Gulf war of 1991.



The Crumbled Wall

In 1989, the world watched as the Berlin Wall fell. In the photo above, West Berliners (left) and East Berliners



The Collapsed Coup ◉

The failed Soviet coup of 1991 brought tanks to Moscow, to the horror of



Conversations With Two Former Directors

Arthur C. Lundahl . . .

... Was the founding Director of the National Photographic Interpretation Center. His involvement with photointelligence dates back to his days as a graduate student in geology at the University of Chicago, where he became intrigued with the wealth of information that could be derived from aerial photography. After serving in the US Navy as a photographic intelligence officer during World War II, he left active duty and joined the Naval Photographic Intelligence Center. He came to CIA in 1953 to establish a photointelligence component and remained with NPIC until 1973.

NPIC's roots can be traced back to 1952 and an entity known as the Photo Intelligence Division (PID), which was under the former Office of Research and Reports (ORR) in the Directorate of Intelligence (DI). Can you describe those early days?

Before PID, there was no photointerpretation within CIA. I came to CIA in 1953, in response to a request by Dr. Otto Guthe, who was the associate director of ORR. Dr. Guthe asked if I would be willing to help organize a CIA photointelligence activity. This question was not entirely unexpected. From late 1951 to early 1952, I had given several guest lectures on photointelligence at CIA. But when Dr. Guthe asked me, I was a little apprehensive. I said, "Who do I have to fight when I get there?" and he said, "No one. We don't have anything established yet." Then I asked, "Well, what does CIA know about photointerpretation?" CIA agreed that it knew nothing, but that it had been impressed by strategic bombing survey reports, which showed that between 80 and 90 percent of all US strategic intelligence in World War (WW) II came from aerial photography, and that it had been very accurate.

The CIA was not a very hospitable environment in 1953. The buildings—M, P, and Q—were temporary structures, located near the Watergate. They were old and dirty. The M Building housed the DI and ORR. When I arrived, there was no place for me, no office, no equipment. In fact, I didn't even have a desk. I did have some very good people, however. As soon as Otto Guthe got my name on the dotted line, some of his former Navy associates, like Norman Beckett, Zigmund Lenchert, Alice Sheldon, J.W. Gardner, and others, had arrived to take positions within PID. We had 12 people divided into two groups: geographic and industrial.

My first job was to find a place for my people to work, get them equipped, and elbow our way into the CIA hierarchy. At the time, CIA was deeply involved in an operation in Guatemala and of course had no overhead photography, but we had hand-



Arthur C. Lundahl

"Our youthfulness, our excellent performance, and our world support made a really great impression."

could be identified and located. Thus, there was no time to become slowly oriented, because we were called upon to produce. But I knew that things would change.

The PID eventually evolved into the Photographic Intelligence Center (PIC). How did this come about?

PIC began to take shape at end of 1954. One morning I was told that [DCI] Allen Dulles's secretary was on the phone and wanted to talk to me. This surprised me. The well-meaning lady on the other end said, "Mr. Lundahl, you're relieved of all of your duties. Report to the Director's office immediately." I left M Building eight steps at a crack and ran to Dulles's office. When I got up there, I was introduced to Dulles and Richard Bissell, who was Special Assistant for Project Control for the DCI. They pulled back a drape and showed me pictures of the proposed U-2 aircraft. I was told they wanted me to forego my other duties and commit myself full-tilt to planning U-2 aircraft missions.

But I knew that I couldn't let everything collapse behind me, because we had customers coming to the door of PID every day. So I told my deputy, Sid Stallings, that the DCI had put me on a very important assignment and that I expected him to manage the store. For all of 1955, I raced back and forth across the US; I watched the U-2 land and take off; I crawled under the aircraft with

Bissell. Whenever I got back to Washington, I would hurry to PID and get familiar with what was going on.

I soon realized I would need many more people, so I went to the Office of Central Reference and told Dr. Jamie Andrews, the associate director, what was happening. I told him the high command wanted me to take 90 of his people and put them in my organization. Dr. Andrews, to his credit, said, "I'm sure this must be the most important project that CIA has going at this time. I will give you 90 people, and I assure you they'll be the best people I've got." And they were. That's where I picked up Dino Brugioni, Bill Banfield, Alan Mayer, and on and on. They were fine people who knew how to handle data and had long experience with library resources at CIA. ORR was to come up with some 60 people, including those I already had.

As our division got bigger, we had to have a larger working area. We were looking around for a place, a factory environment, where we could receive all the U-2 photography. We looked at a lot of different places, until finally we got hold of the Stewart Building on 5th and K Streets, NW. The automobile agency owned the lower three floors, and the upper four floors were unoccupied. CIA rented them.

Our size now was approaching office level, so I felt it would be logical to call us a photographic interpretation center. The Office of Security had some reservations about that, so I came up with the words "HT Automat." Why did we call it that? Well, I reasoned that as all the data flowed in, people would be coming in on weekends, holidays, and in the middle of the night—just like the automats in New York City where people are eating turkey dinners at 3 a.m.

Soon, I was permitted to brief the Army, Navy, and Air Force on what we were doing. I went after the Army first. I got several Army chiefs together and laid out the U-2 program. I asked if they wanted in on it. They certainly did. The Army came up with 90 people and almost \$2 million. The Navy had a more modest bid; they already had a photointerpretation center, which I had helped build, so they decided to send only a small representative group. The Air Force treated it all like a miserable dream, because reconnaissance had always been their lifeblood. The Air Force thought that if they made a commitment, they would be agreeing that CIA had a right to do this. So they only sent a couple of liaison officers over.

R. M. Huffstutler . . .

... The fourth Director of NPIC, is a career intelligence officer and current Deputy Director for Administration of CIA. A native of California, he holds both bachelor's and master's degrees in economics from the University of California at Berkeley. His initial assignment at CIA was as an economic analyst; in 1959, he was transferred to a small task force working on the "missile gap." That was his introduction to military intelligence and to photointelligence. From that time on, he served in a number of analytical and managerial roles in the Directorate of Intelligence. In 1984 he came to NPIC; in 1988, he accepted his current position.

You came to NPIC with a vision of what we, as a National Center, could be. Will you describe that vision?

NPIC stands at the heart of the imagery business. It is wonderfully positioned to advise on customer needs, as well as exploitation opportunities, by virtue of its role as a primary intelligence producer, its wide contacts with intelligence and operational components, and its broad dealings with industry. NPIC has the talent, the depth, and the outlook to make a critical contribution to the nation's security.

How did you view NPIC prior to coming on board as Director, and what new or surprising insights did you gain while you were here?

I was familiar with NPIC, the substantive Center, arriving as I had from many years as a major customer. I was surprised and impressed by the scope and complexity of the many activities that make the substantive product possible. Tasking activities, data-base designs, mensuration support, library assets, film quality control, information dissemination, new terminal procurements, analyst training, to name a few, all had to be orchestrated to create the product. This was a daunting task. What made it fun was the enthusiasm and dedication of my colleagues at the Center.

Your tenure as Director has been considered a period of significant growth for NPIC. Indeed, several "metamorphoses" occurred under your direction; among them: the intensification of NPIC's modernization program and a hiring surge. How do you believe these events shaped the National Center?

The modernization program had a major impact on the imagery community as well as on NPIC. The modernization was so extensive, so complex, and so expensive, that no other organization had the resources or,



R. M. Huffstutler

"NPIC and imagery made arms control possible."

more important, the skilled people to deal with it. The result was that NPIC was thrust into a position of prominence and called upon to provide leadership for the entire community. Not only were regular gatherings scheduled to update community imagery managers on programmatic and technical developments, but organized efforts were made to represent their interests in design and program requirements. One of the earliest efforts was to create a light table mensuration system which could be used as an affordable, stand-alone capability for reconnaissance centers as well as large exploitation centers. Such efforts eventually led to the creation of the National Exploitation Laboratory as a service of common concern.

The explosive growth of NPIC posed different issues. When a very stable organization suddenly expands, the established, informal communications and career environment are disrupted. People become apprehensive when their expectations are jeopardized. To deal with this situation, senior managers spent almost a year designing and implementing the NPIC personnel system, the purpose of which was to help employees understand how their performance is measured, and thus, to achieve some control over their careers. Many manifestations of this effort remain, such as offsite meetings at Port Deposit, which were part of the implementation plan for the new personnel system, and the rotation program, which so far has produced two Agency office directors and a deputy from the NPIC career service.

If you were to summarize your time at NPIC, what would you cite as the one or two defining events?

The proliferation of mobile missiles and the growing arsenal of precision-guided weapons would get my vote. The mobile missile forced us to think differently about how we targeted collection, reported, integrated sources and methods, and designed data bases. The need for more flexible collection management arose in large measure from the challenges posed by this development.

The increasing reliance on precision-guided weapons necessitated more fine-grained imagery analysis. The difficulty of tracking mobile missiles, as well as the awesome potential of precision-guided weapons targeted on the basis of imagery, were demonstrated in the recent Gulf conflict.

You have been gone from NPIC for several years now. What lasting impressions remain with you? Do any of these impressions influence your work as Deputy Director for Administration?

My strongest impression of NPIC is of people who could overcome chaos and adversity to do important work. The mid-1980s was a time when Building 213 was in shambles, the neighborhood looked like Beirut, familiar ADP systems were being replaced by new hardware and software that had not been stabilized, and demands for work threatened to swamp us. I remember 1985 as an extraordinarily difficult year. Nonetheless, people rose to the challenges, and by 1986 it was clear we would succeed. This period was a lasting lesson in how much people can achieve. It is the basis for my confidence that we in the Agency will successfully manage our way through the challenges of downsizing, shrinking resources, and changing intelligence demands to emerge a vital and effective organization during the next decade.

What do you view as NPIC's major contributions to national security and to policymakers over the past 30 years?

NPIC and imagery made arms control possible. Without this high degree of confidence in the military status of a potential adversary, no agreement would have been politically achievable. Moreover, imagery has contributed in a substantially new way toward strategic stability. The many false alarms that might have initiated confrontation, the military exercises that might have been interpreted as invasions, even the invasions that were discerned to be limited might easily have sparked hostilities involving the United States had NPIC not been available to keep them in perspective. I believe NPIC can be proud of its contributions to peace as well as to the nation's security.

Lundahl continued from page 6 . . .

If PIC had some degree of military cooperation, why was there a need for a national photographic interpretation center?

Based on my experiences, I was committed to the idea of national photointerpretation centers. I had been in British centers, where Army, Navy and Air Force people work side by side. Even in my own Navy command in Adak in the Aleutians, we had Navy, Army, and Army Air Forces working together. We developed a technique that the majority view—the preponderance of evidence—would be the basis of the report, and minority views or contrary interpretations would be footnoted.

By 1956, we were essentially functioning like a national center but without a charter. We had groups and liaisons from Army, Navy, and Air Force, as well as standby groups from NSA and the State Department, all functioning under Automat. So I gathered them together and said, "This isn't a CIA fiefdom. This is a national activity. With each mission, a different one of you will be the mission leader." Well, Army and Navy went back to their commands and said, "You know, CIA is not fooling. They are actually running this thing like a national center." Finally, the Air Force agreed to put a representative group in the building.

In 1960 and 1961, radical things began to happen. The U-2, after four years of very successful operations, was shot down on 1 May 1960. Following the shootdown, a large intelligence panel was put together under Lyman Kirkpatrick, the number-three man at CIA. For a year, the Kirkpatrick Commission studied the whole intelligence structure of the United States and made a number of important recommendations in their final report. One was to establish a national center. That resulted in NSCID [National Security Council Intelligence Directive] 8. Now, NPIC had a charter which fully covered all we had been doing and gave us even more authority with the unified and specified commands.

What factors compelled President Eisenhower to sign NSCID 8, and why did he elect to keep NPIC under the CIA?

This is a very interesting story recorded nowhere else. When President Eisenhower was considering whether to sign NSCID 8, the Air Force questioned who should be empowered to run NPIC. A debate began at the US Intelligence Board, and the Air Force felt that this was the time to put the National Center back under the control of the military. The Army said that CIA had done a great job running NPIC and should continue to run it. The Navy agreed. The Air Force said that the Joint Chiefs of Staff should run it, with the Air Force serving as executive agent. After four abortive sessions, the question remained divided.

The problem finally was raised to the NSC. Army again said that the CIA should

continue to run it. Navy said maybe NPIC should be run by the military, and its vote disappeared. And the Air Force made its appeal again. Eisenhower, who had been listening to the debate, turned to his science adviser, Dr. George Klitkowsky, and asked his opinion. George said, "Well, Mr. President, I've been over to the Stuart Building and I like what they do. They're young—the average age is 29; they're intelligent; and they've served me well when I've been over there. This field is so new, so esoteric, and so complex, that I'd like to see these young specialists grow and stay with it. A military officer usually cannot confine his career completely to intelligence, and we cannot have interruptions in something as important or as cumulative as photointerpretation."

"Having military and CIA personnel together was the essential element of the joint center."

Eisenhower thought about it and turned to Allen Dulles and said, "Allen, this is going to be yours. You are going to control NPIC." Allen Dulles thanked him for the honor, and to show that this was not to be a CIA fiefdom, offered the military the opportunity to provide a deputy to the Center. Another panel was convened, chaired by General Graves Erskine, a Marine Corps four-star general, to listen to the bids as to who should have the first deputy director. Army's bid was very strong. They had been in from the earliest, supported it the heaviest, and were the most vocal supporters at present. Navy had a modest bid. The Air Force bid was almost too weak to mention. Erskine decided that Army would provide the first deputy director, then it would rotate among the three services.

Our youthfulness; our excellent performance; our world support to the unified and specified commands; and the way we handled visitors and provided services had made a really great impression. That's how the folio came to us.

Why was it important that NPIC be jointly staffed by CIA and DIA?

Having military and CIA personnel together was the essential element in having a joint center. In the early days, before the sophisticated overflight programs like U-2, photography would be exploited by Air Force, Navy, and Army, and you could get completely different reports on certain subjects. It left the person at the top in a quandary over who was right in this particular instance. Well, the president didn't have time to sort these things out, so it was essential that we

sort out the views. And it was easier to do that when DIA and CIA representatives, as well as State Department and NSA representatives, were together in one building.

NPIC's first "home" was the Stuart Building. Tell us about those days.

The Stuart Building was not the finest building in the world. There was no place to eat, no place to park, no air conditioning, and our people were getting mugged on the streets even before it was fashionable. I guess the best thing you could say is that we had wonderful security cover, because I'm sure nobody would ever believe that anything of any importance to the United States could be taking place in this trashy neighborhood. But we were there, and that's where the Cuban photography arrived.

When the Navy would come to Stuart to receive its allotment of film, it would deploy a vehicle to pick up the materials and an armed detachment to block off the sidewalk. Here were sailors with machine guns standing on either side of the building entrance, as film cans and boxes were being moved out. It had the natives of the area wondering what we did. I'm sure they were convinced we were printing money, because there was nothing else in this world important enough to have earned an armed detachment.

The Cuban missile crisis of 1962 served as a defining event for NPIC. Which moments of the crisis stand out most in your mind?

This was a great period. People who had never heard of us now knew that there was such a thing as NPIC. Our popularity zoomed off the scale. Many interesting things happened during those early days to bring NPIC great credit. For example, I went with [DCI] John McCone to brief Congress as to how we discovered the sites in Cuba—how soon we discovered them, and if we could have discovered them sooner. There were some who thought we could have detected the missiles earlier, so we prepared briefing boards showing the sites near San Cristobal a few days before October 14 and a few days after. Based on these, the committees concluded that in some cases, if we had looked at the site even a few days earlier, we would have concluded there was nothing there. I chucked to myself when Senator Stennis from Mississippi, in his inimitable Southern accent, said, "Well son, I wish we could put this whole thing in the Congressional Record and show how we were right on the money. And I think Mr. McCone deserves a great round of credit for being right on top of this problem." This started a whole wave of flowery speeches from other senators, each crediting Mr. McCone for a job well done.

After that briefing, I went back to the Building, and Mr. McCone followed shortly after me. The auditorium was filled with people, and I reported what had happened in

NEVADA

HALL OF FAME

Congress. Then, Mr. McCone arrived and thanked the group for their performance and said that the NPIC materials had helped save the day. I explained to Mr. McCone that NPIC people would rather have some small role in the making of history than a seat on the 50-yard line watching it be made by someone else. That proved to be true over and over again. Some of these moments were very hard to forget because they were full of meaning and glory for so many people.

"NPIC was the place to be in those days . . . the biggest, best, and most exciting game in town."

Of course, there were embarrassing moments. I think my most embarrassing moment at NPIC occurred at the start of the Cuban missile crisis. When photography was processed, many duplicate negatives and positives had to be sent to the various commands. In October 1962, even as we were looking at the fateful pictures over San Cristobal, we had already begun distributing duplicate negatives of that same mission to a naval command in Norfolk. After we discovered the MRBM sites and briefed Kennedy, he wanted the information completely contained. Well, we were worried about the set of negatives that had already been distributed to Norfolk. So, we got the people in Norfolk on the phone and told them that the plots for the mission had to be renumbered and some processing changes had to be made. We offered to send a courier to pick up the film and to replace it with the correct material in a short time. No one was alerted or suspicious and we got the film back, and I could truthfully tell President Kennedy that all the materials were in our hands. But you can imagine that I was worried for a few hours!

Shortly after the crisis, NPIC moved into a new home. How did we acquire Building 213?

When John McCone was DCI, he used to bring the President's Foreign Intelligence Advisory Board (PFIAB) over to Steuart. These gentlemen would arrive on 5th and K in a column of limousines. The streets were dirty and windows were sleeping along the curbs. The PFIAB went back to President Kennedy and said, "Mr. President, you've got to get those people out of there. They're working under foxhole conditions." So Kennedy called McCone and said, "John, what are you doing about getting those people out of the Steuart Building?" McCone was ready. "Mr. President," he said, "We are working on a new building for them in the naval gun factory, Building 213. I shall have them out of the

Steuart Building on 1 January 1963." They started working on it 1 January 1962 and spent \$17 million to redo it. True to Mr. McCone's word, we moved into the Building on 1 January 1963.

What was your reaction when you saw the finished building?

It seemed like a dream come true. Walking through the gates and seeing Building 213 in its white splendor, it almost looked like the Taj Mahal. Sure, everything wasn't perfect, but it looked like a palace to me. I was so delighted I couldn't get over it.

A few days later, Mr. McCone came to visit. He walked through the Building and was impressed. He looked at the marble walls in the lobby, and said, "Do you think that marble is a good idea?" I replied, "Yes, Mr. McCone. A painted wall has to be repainted every three or four years, but marble lasts. It's cost effective." He shook his head, smiled a bit, and said, "Well, Art, you've gone from rags to riches."

What events, both intelligence and nonintelligence related, helped shape NPIC through the years?

There were far too many to describe in detail here, but I will mention a few. For example, long before Cuba, we were quite concerned with the antecedents to the Suez crisis. We were aware of the change of deployment of French transport aircraft and of British aircraft and ships. We were convinced that an amphibious operation was being set up, and we were in the process of reporting that when the French and British joint task force landed in Egypt. That was surprising, but we at the Center were not totally unprepared.

We helped the President in connection with the bomber, missile, and megatonnage gaps. We proved in rapid succession that these gaps, as President Eisenhower would later explain, were mere myths fabricated by Premier Khrushchev.

We also developed a pretty secure feeling about where the Soviets were in their nuclear testing program, and this permitted the President to be far more forceful than he might otherwise have been. When the showdown over Cuba came, it was clear to President Kennedy that we had the preponderance of force necessary to win.

Another thing that bothered us for a long time was the so-called Caspian Sea "monster." This huge aircraft could have been a very important logistic element in war. But for many years we wrestled with the ultimate disposition of that monster.

NPIC was the place to be in those days. If you didn't have the tickets—the security clearances—to get into NPIC for a briefing, you were nothing in Washington. We were the biggest, the best, and the most exciting game in town.

As Director of NPIC, you came in contact with several presidents and many key political figures. What do you recall of them and of their views of the value of photointelligence?

Over the years, I did get to see many different leaders from many different countries and was privileged to present to them, with the blessing of the president, NPIC-prepared briefing packages. Not the deed to the whole ranch, but certain specific subjects on certain areas at certain times.

I was privileged to brief Prime Minister Macmillan of England; General DeGaulle of France; Konrad Adenauer of West Germany; Nehru of India; Chiang Kai-shek of China; Menzies of Australia, and certain Turkish leaders. All these briefings met with success. Some world leaders were slightly incredulous over what we showed them. Adenauer kept murmuring, "Fabelhaft, fabelhaft [fabulous, fabulous]."

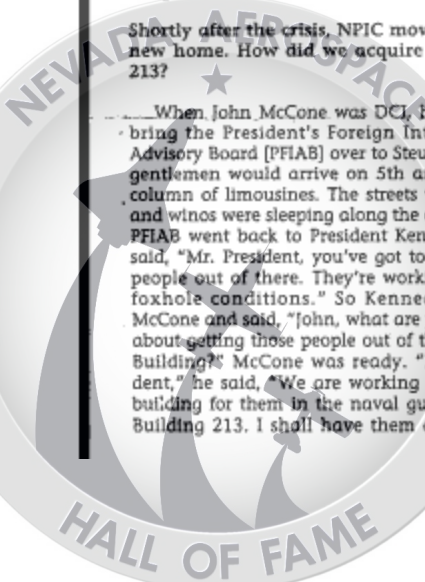
"Wherever there is a big event, photography will be called for."

When Eisenhower was leaving office and wanted to make sure that President Kennedy understood the scope and the depth of our efforts, he arranged for me to brief them at the same time. Some months later, when Kennedy was President and Eisenhower was back in Washington on a visit, I was again at the White House, briefing them both on our latest accomplishments. Dwight Eisenhower not only had guts enough to start pre-hostility reconnaissance, but he kept track of it all during his administration and after he left public office. Even on his last days, when he was lying in Walter Reed Hospital, he made it known to [DCI] Richard Helms that he would like to be brought up to speed, and I briefed him at his bedside.

What advice could you offer to imagery analysts of today?

My advice to young women and men at NPIC is to study, study, study and read—whatever your specialty, read everything you can about it.

I also think that all PIs should be very familiar with geography, with weather, and with the ethnic properties of the various nations they study, because many times the cultural attributes of the land can be readily mistaken for a military threat. We had great problems in China, where they built these enormous redoubts, apparently for anchor-



and 30th Anniversary

Three Decades . . . Two Homes

NPIC's first home was not in a government compound, but in the heart of the city: Fifth and K Streets, NW. The Photo Intelligence Division, the predecessor organization to NPIC, moved into the Stuart Motor Car Company Building in 1956 and occupied the top four floors. The bottom three floors were used by the car company and by the Stuart real estate office. The Stuart Building was not exactly Trump Tower: there was poor ventilation, no air conditioning, and no parking. The surrounding neighborhood was rough—crime ridden and impoverished—even though it was located across the street from a police station.

When NPIC moved to Building 213 on 1 January 1963, it was a definite step up in the world. In fact, the building was such an improvement that many NPICers called it "Lundahl's Palace."

Building 213 is situated in the Washington Navy Yard, an area rich with history. Shipbuilding began there in 1800, as the US moved toward impending war with France. As the Navy's home port throughout the 1800s, the area was rapidly filled with wharves, warehouses, and refineries. By the turn of the century, however, the Navy Yard had taken on more of an industrial character, evolving from shipbuilding to ordnance manufacturing. The area experienced a growth spurt between World Wars I and II.

In 1944, the Navy built Building 213 to store steel blanks for guns. By the early 1960s, all weapons production had stopped, and the Yard was divided in two. One half was retained by the Navy; the other half, of which NPIC is part, was transferred to General Services Administration on 1 October 1963.

In the years since NPIC took possession of 213, many changes and improvements have taken place. The building has been renovated from top to bottom, and in the 1980s, a six-story addition was constructed to house the rapidly growing workforce. Currently, three new guardhouses and a new perimeter fence are being constructed and the facade is being refurbished. □



Past and Present: NPIC's two homes now stand worlds apart. The Stuart Building (left) is vacant and dilapidated. Building 213 continues to be renovated, refurbished, and modified to fit the needs of the NPIC workforce.

Anchors Within NPIC

"Your office is relocating again?"

That phrase has become a standard part of NPIC conversation over the last several years, as work units relocate on an all-too-frequent basis. Almost without warning, it seems, an office moves from the first floor to the third, or the fourth, or the sixth. In the face of near-constant movement, it is nice to know that several Building 213 components have remained in the same location since 1963: the photolab, DIA, the auditorium, and the Director's office.

For the past 28 years, the photolab, part of the Exploitation Support Group (ESG), has been located on the center wing of the second floor of Building 213. It has remained in place primarily for efficiency's sake: moving the lab's chemical "tank farm" and extensive system of pipes would be far too labor and cost intensive.

Lack of movement does not imply lack of change, however. Until the early 1980s, the lab occupied 24,000 square feet of floorspace. In 1982 and 1983, the lab was remodeled to accommodate the conversion from hand processing to automated processing and to provide more floorspace for NPIC's rapidly growing computer center. As a result, the photolab lost more than 40 percent of its floorspace, ending up with its current total of 14,000 square feet. The bulky hand-processing equipment took up a great deal of space and once it was gone, the photolab became "more streamlined and efficient," according to Dave Kough, its current chief.

(As the lab was renovated and the computer center expanded, a key building move occurred: the printshop, which had been located on the second floor, was moved to the sixth floor; later, the compo-

ment was moved once again, to its current location on the first floor.)

DIA, like the photolab, has never moved from its original location. The fifth floor has been "home" to Army, Navy, and Air Force representatives since 1963.

The Building 213 auditorium, on the north end of the sixth floor, has not been relocated for obvious reasons, but in the early 1980s, it was used as temporary office space for the Imagery Exploitation Group.

The Director's office, located on the north wing of the sixth floor, also has remained in place since the beginning, although the area has been modernized and renovated from time to time. Precisely why the office has never been relocated is not known, but some speculate it is because that suite affords a panoramic view of the Capitol. □

NEVADA

HALL OF FAME

and 30th Anniversary

Setting Sights on Career Development

Helping individuals develop to their fullest potential has been part of the NPIC credo for 30 years. To accomplish this, NPIC has pursued a robust program of career development—a program highlighted by the following elements:

Career Service Panels

To ensure that NPIC's personnel policies are administered equitably, NPIC adopted an innovative career service panel (CSP) system in the 1980s. NPIC currently has a Center-level panel, which is chaired by the Director and oversees Center-wide policies and personnel actions for GS-14s and -15s; panels for each of the seven NPIC groups; and three secretarial panels, chaired by NPIC's Executive Officer and by the executive secretary to the Director. The panels meet regularly to recommend promotions, assign comparative evaluation ratings, and approve reassignments, rotations, and some types of training. Recently, a minority advocate and a women's advocate were appointed as voting members to each panel.

In 1986, the basic precepts of NPIC's personnel management system were codified in both supervisors' and employees' handbooks. (A corresponding version was published for contractors.) In addition to containing basic personnel policies, the handbooks describe NPIC's career development philosophy and essential administrative information. The handbooks were revised in the late 1980s and are being revised again.

Training

Very few American colleges or universities prepare students to do the essential work of NPIC: imagery analysis. To meet the needs for specialized job-skills training, NPIC began its own "training school" in the 1970s. The premier offering was a basic imagery analysis course, which was instituted in 1978.

Little by little, the school grew in size, scope, and subject matter, and eventually evolved into a full-fledged division with a wide-ranging curriculum. The National Imagery Analysis Course (NIAC), as it is now known, remains a mainstay of the division, but has grown considerably since its "basic" days. In the mid-1980s, the course gained academic accreditation. On 13 December, the 75th NIAC class will graduate.

Other skills are developed, too. Probably the first course that any NPIC employee will take is the New Employees Orientation Course. Later, employees likely will take advantage of any of several computer courses offered in-house or dozens available externally or through self-study. Advanced writing workshops and briefing techniques courses are favorites among employees as well.

The in-house staff of instructors has developed several highly innovative, unique-to-NPIC programs. Among the more progressive are the Ethics Awareness Seminar, the Lead-



Career Control: NPIC offers many resources designed to help employees, like FESG (above), enhance existing skills or learn new skills.

ership Development Program, and the Supervisory Counseling Course.

This is not to say that NPIC employees never venture outside Building 213 for training. Employees take advantage of the many courses offered by the CIA's Office of Training and Education, by other Intelligence Community organizations, by external contractors, and by colleges and universities.

NPIC sponsors several employees for full-time academic training each year. To expand the educational opportunities available to ethnic minorities, the Center also sponsors between three and five qualified minority employees each year for full-time undergraduate or graduate academic training.

In the future, training at NPIC will become even more responsive to the needs of a changing workforce. Currently, NPIC is aggressively exploring training courses that focus on multicultural diversity.

Career Development Office

Former Director Frank Ruocco created an in-house Career Development Office (CDO) in 1989. This office serves as a Center-wide resource for career exploration and development; job-related issues; personal counseling; and grievance, discrimination, and EEO issues.

Rotations and Reassignments

The strongest workforce is a well-rounded workforce. With this axiom in mind, NPIC management long has encouraged employees to develop their career potential and gain new insights by "testing the waters" outside NPIC. This is done largely through rotational assignments, generally one or two years in length, which focus on strengthening existing skills and career potential or developing new skills critical to NPIC's mis-

sion. Employees can apply for rotational assignments through the standard CIA vacancy notice system or through NPIC's Career Development Call. The "call," held each February, enables employees to request specific reassignments within NPIC, within CIA, or elsewhere in the Intelligence Community.

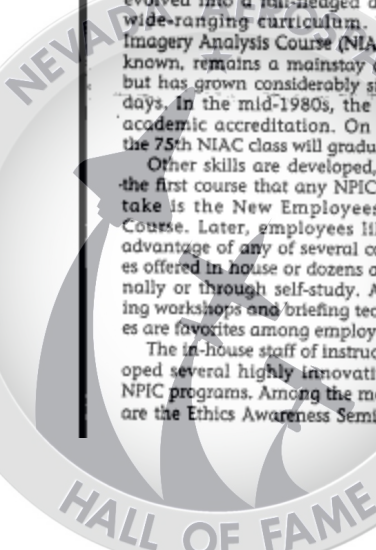
Employees seeking reassignment (a direct transfer to another NPIC group or CIA office) also can gain assistance at NPIC through Personnel Division and the CDO.

Awards and Recognition

The names may sound funny—Eagle Eye, Search Ace, Feather in Your Cap, Soar With Eagles, the Order of the Eagle—but the meaning is quite profound. These unique-to-NPIC honors, initiated in the mid-1980s, recognize an extraordinary performance or, in the case of the Order of the Eagle, five extraordinary performances.

For fiscal year 1992, Director Leo Hazlewood has created four new awards to be presented annually: the Secretary of the Year Award, the Multicultural Diversity Award (for the person who has done the most to advance this goal during the year), the Professional Mentor Award (for exceptional skills and talents in this area), and the Lundahl Award (for the person whose performance best exemplifies the standards of excellence associated with NPIC's first director). The awards will include money and a distinctive memento. The Lundahl Award winner, if assigned to Building 213, also will receive the open parking space on NPIC's "executive row" for that year.

These programs and many others prove that NPIC's attention may be focused on the world, but the Center hasn't forgotten about its people. □



The March of Technology

Tracking NPIC's technological advances is a bit like watching a parade: your view depends on your seat in the reviewing stand. High "techies" at NPIC are likely to believe that automated change came at a snail's pace, upgrade by upgrade. Low techies (those who still gasp at the sight of a Wang terminal) might differ in their assessment; for them, the changes were lightning fast.

Whatever your view, this much is certain: technology has not stood still. To gain a sense of just how sweeping the changes have been, consider some of the advances made over the past three decades.

Computers

ALWAC III-E: Used in the Steuart Building and later in Building 213 for U-2 mensuration, the ALWAC was a total-batch-process system, which meant that operators could load data in and get data out in batches, but could not alter the process once it began. The cumbersome system worked on paper-tape input and output and had a vacuum-tube (vice magnetic) memory. But even the ALWAC was revolutionary: It was one of the first digital computers in the Agency.

IBM 407 and 1401: The 407 was a punch-card "lister" and required total-batch processing. It generated "blip sheets"—massive paper printouts with up to seven carbon copies of historical data and blank data-entry forms. Photointerpreters (PIs) would enter the readouts, in longhand, on the entry forms. A data-entry operator would punch the data onto the cards. One sidenote: producing blip sheets from the 407 took an entire weekend. The 1401, the later generation model, accompanied NPIC on its move from the Steuart Building. It provided mensuration and information processing and featured four magnetic tape drives and 8,000 bytes of memory. One big advance: blip sheets could be produced in three to four hours with the 1401.

Univac 490 and 494: Like its forerunners, the Univac 490 (introduced in 1962) was a total-batch system, but this model provided 32,000 words of memory and was used initially for mensuration and later for information processing.

In 1968, the Univac 494 introduced NPIC to the wonders of remote-batch processing, where computing could be controlled away from the central computer. Two terminals were used with the 494: initially, the Sanders 920 and later, the Sanders 804. NPIC's 10 tailor-made, state-of-the-art 920s each weighed 600 pounds and needed a floor fan to keep from overheating. The 804 was the first online interactive terminal used by imagery analysts (IAs)—on a limited basis. A "paperless branch" was formed in the Imagery Exploitation Group (IEG) to allow a cadre of IAs to try their hand at automation.

Univac 1100s: This series of computers was added in 1975. Remember Delta Data terminals and light pens? Then you remem-

ber debut in 1981. Online interactive terminals became indispensable tools of the trade for NPIC's IAs.

Unisys 1100/90s: In 1986, a new online interactive system appeared at NPIC. The Sun terminals were the next wave in computing and the first observable wave of NPIC's modernization program. Gone was the light pen, replaced by a mouse.

How far have we come? Today, NPIC's world-class computing power emanates from two Unisys 1100/93s and one Unisys 1100/91. Together, these systems offer 160 million bytes of memory and 146 billion bytes of storage and process 48,000 transactions a day.

Light Tables and Optics

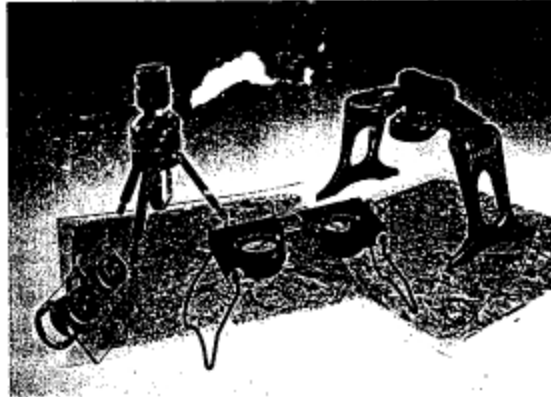
"Light Boxes" and Scopes: In the 1960s, PIs were using light boxes of varying sizes (9 by 18 inch or 9 by 40 inch, typically). Some

light boxes featured tilt tops; all relied upon crank reels. A wide assortment of optics—many pocket sized—were used: tube magnifiers, stereoscopes, stereomicroscopes, and "dynazooms." One memorable version, called the "rocket," was a tall, tube-shaped magnifier supported by three "legs." It looked as if it might launch at a moment's notice.

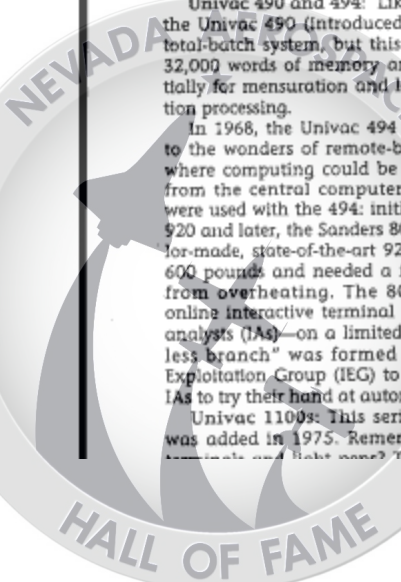
During the 1960s, PIs also used the Richardson Film Viewer, which projected images onto a large, ground-glass screen and generally required a team of interpreters and a collateral researcher.

AIL 1540: This light table was introduced at NPIC in the early 1970s and remains in use today. With the 1540, we were zooming to high powers, using the Zoom 240- and 500-series stereomicroscopes.

Richards HFO-4: Currently the light table of choice, the HFO-4 has been around



Old Optics, New Options: Pocket-sized optics like those displayed above were once standard tools of the exploitation trade. They have been replaced, in part, by IDEX II, which offers push-button convenience, as demonstrated by ESG (background) and [redacted] of IEG.



since the 1980s and typically is paired with the Zoom 500 stereomicroscope.

Soft-Copy Exploitation

DIM: Taking a cue from NASA, which applied digital technology to enhance images of the moon, NPIC journeyed into the realm of digital, soft-copy image enhancement at the beginning of the 1970s, with the Digital Image Manipulation (DIM) system. The DIM allowed image scientists to enhance very small areas of digitized imagery.

IDIMS: In 1976, NPIC took a quantum leap forward with the Interactive Digital Image Manipulation System (IDIMS). With greater computing power and a wider variety of algorithms, the IDIMS allowed a wider range of image-enhancement capabilities. It has undergone numerous upgrades and remains in service today. Still, it was built for the scientist, not the IA.

IISEM: The prototype to today's soft-copy systems, the Imagery Interpretation System-Engineering Model, or IISEM, was installed at NPIC in the late 1970s and enabled analysts to manipulate digital data on a TV screen.

IDEX I and IDEX IA: In 1982, after a successful IISEM trial, the Image Data Exploitation (IDEX) system was installed at NPIC. With IDEX I, the basic functions of DIM and IDIMS, plus more sophisticated processing, could be done with the push of a button. The IDEX IA, a new-and-improved IDEX station, was activated in 1985.

IDEX II: The long-awaited IDEX II became operational at NPIC early this year and provides IAs with many advanced features. With the advent of IDEX II, the IDEX I system was phased out.

Measurement

In days of yore (circa 1960s), specialists who wanted to take measurements of an object on film were "floored"—literally. Handheld photos were pinned to a cork floor and measurements were obtained by drawing vanishing points on the floor.

We've come a long way. Over the past three decades, we've used the reticle on tube magnifiers, photo slide rules, stereocomparators (like the Nistr, NRI, and Mann); the one-of-a-kind, high-precision stereocomparator that weighed 15 tons and was set on bedrock; and digital stereocomparators. In the 1980s, analysts were able to make measurements at their workstations through the light table mensuration system. Today, photogrammetrists also use the Intergraph system for measurements and evaluation.

Office Automation

Think back far enough and you can probably still hear the pounding of a manual typewriter—the office tool of the 1960s. In the space of three decades, those workhorses were replaced by electric typewriters; by IBM Selectric typewriters; by IBM Magnetic Card typewriters; and finally, by the Wang word processor.

"Make me a carbon copy of this." Those were dreaded words if you ever handled a car-

bon paper smudge. Carbon copies eventually were replaced by thermofaxing, a copying technique that used infrared light and heat-sensitive paper. The result? Only the densest tones were copied. Today, we rely on user-friendly photocopiers.

Calculate this progression of developments: 40-pound mechanical desk calculators (retailing at about \$400 in the 1970s) were eventually replaced by hand calculators (about \$400), which in turn were replaced by more advanced (and mass-produced) hand calculators (about \$40). Now, personal computers often are used for calculating. Their cost? About \$4,000. Such is progress.

Publishing

Over the course of 30 years, the cut-and-paste technique has, for the most part, been replaced by desktop publishing. At NPIC, the Graphics Production System, the Macintosh, Intergraph, Genigraphics, ATEX, and the Autologic Phototypesetter are used.

Processing

In the printshop, we've gone all the way from the mimeograph machine to a new, fully computerized, five-color offset press. In the photolab, the standard operating equipment has remained the same for the most part, with a few key refinements. The photolab doesn't believe in casting off old machinery: they still have serial #0001 of the Beacon Precision Enlarger!

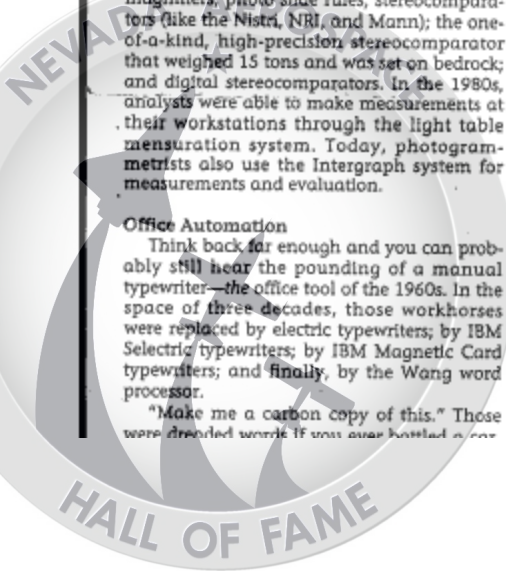
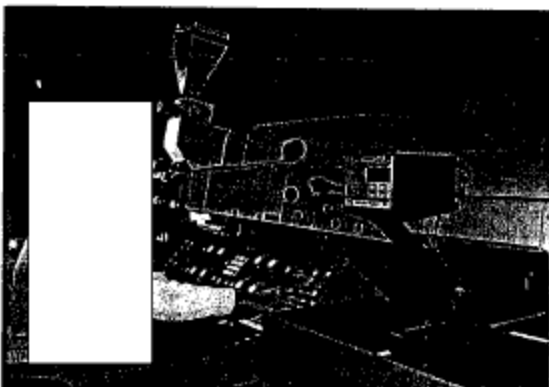
Security

The security system in our early days had one critical component: [redacted] The former Stuart Building elevator operator knew every employee's face and badge number and had badges ready for each person as they entered the building. [redacted] eventually was replaced by a team of guards who also "read faces"; they in turn were replaced by badge machines, which read magnetic strips (but do not smile and say "good morning").

Ah, for the good old days. □



Modernizing Measurements: How do you gauge progress in the mensuration business? Look at these photos. The photo above shows an old comparator, used during the 1960s and 1970s. The photo below shows a high-precision stereocomparator, with [redacted] of ESG behind the space-age control panel.



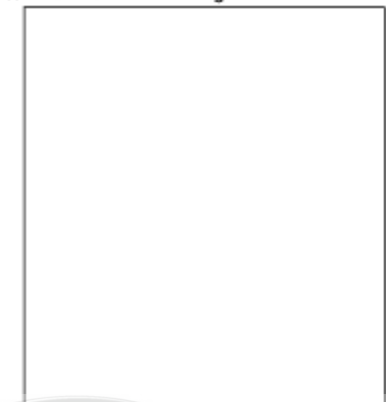
Time Flies: 'Veterans' Reflect on Three Decades at NPIC

Thirty years can change a person. It can give you a spouse, a family, and a mortgage. Thirty years, when spent in the same organization, also can give you a sense of perspective, a sense of what it was like "to be there when . . ."

So it is with each of the employees profiled below. They came to NPIC in 1961 (or earlier) with different goals and aptitudes. Each remains in the organization today, and each has a special story to tell.

For 30 years, [redacted] has enjoyed a "picturesque" career. It has been filled with astounding photo images, a couple of rogue operations, and more than a smattering of history.

Almost from the start, [redacted] NPIC career took on historic proportions. Now a deputy division chief in the Imagery Exploitation Group (IEG), [redacted] came to NPIC back in 1961 as a courier. It was in this role that he found himself having access to some of the most noted figures of the time.



"As a courier, I had the chance to drive Mr. Lundahl to meetings and accompany him to briefings. I remember back in 1962 taking him to a briefing at the White House, where he and I were alone in the room with former President Eisenhower, President Kennedy, and Secretary of State Dean Rusk. On other occasions, I took him to meetings with General Maxwell Taylor, General Curtis LeMay, and Bobby Kennedy," he recalls.

[redacted] was a bit "overwhelmed" by the company he kept, but recalls that he never felt out of place. "Art Lundahl made you feel equal and important—no matter what you did for a living."

His exposure to photointerpretation led him to change career fields. His career choice could not have come at a more propitious time. In October 1962, as he was attending photointerpretation training at the Naval Air Intelligence Officers School in Anacostia, Maryland, Soviet offensive missile war

crisis was beginning, [redacted] and 15 other NPIC photointerpreters (PIs) in training were called back to work at the Center on evenings and weekends.

"I guess you could say that I started my photointerpretation career with a bang. I was thrown right in," he recalls. The Cuban crisis continued for months after [redacted] formal PI training, and the IEG manager considers the crisis the best supplemental training he could have received. "We sometimes worked for days without going home, but we never tired of it because we knew we were doing something important. The nation was on the brink of nuclear war, and everything we did at NPIC was crucial to what the President and the military did."

Despite being a neophyte PI, [redacted] did not feel intimidated. "There was no time for intimidation!" he says with a laugh. "Besides, we all worked as a team during the crisis. The camaraderie could not have been better; there was no separation between jobs, no 'us versus them.' I made a lot of solid friendships during that crisis that have lasted all this time."

In 1963, as the postcrisis coverage continued, NPIC moved to Building 213, and [redacted] remembers the experience well. "This building was a big step up from the ancient Steuart Building. In Steuart, we were jammed into offices. I worked in an office with seven people and five desks! The last two people in to work every day had to go look for workspaces somewhere else. When we moved into NPIC, we occupied only 25 percent of the building. These were big, brand new work areas."

Hot Projects

During the 1960s, [redacted] worked on a number of "hot" projects, ranging from a four-month tour in Miami to covering Israel's Six-Day War. In 1971, he left the light table to become a deputy branch chief. Later in the 1970s, he spent a rotational assignment in the Directorate of Intelligence's former Office of Strategic Research (OSR), working as a liaison between OSR, the Office of Imagery Analysis, and NPIC; he ran the Basic Imagery Analysis School from 1978 to 1980; and he served as a deputy division chief at the Priority Exploitation Group.

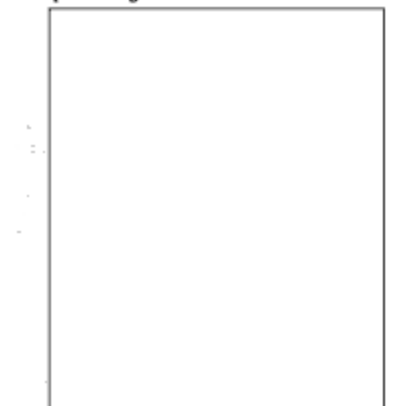
Through it all, [redacted] has seen a career's worth of changes. One of the biggest is computerization. "Computers are a major part of the imagery analyst's [IA] work now. When I was a PI, we didn't have computers, we had 'blip books'—big binders with computer printouts full of information." The blip books were kept in a central location, and the PI would have to leave the light table, get the book, and read through it to find his or her target. And everything the PI did was handwritten. "Now, you just use the keyboard at your workstation to call up everything you need."

The visual tools of the trade have changed radically, as well. "Years ago, most exploitation was done with a 7-power tube magnifier, a lens that you wore on a chain around your neck. You placed it on top of the film and you put your eye up against it, so your eye was almost on top of the film," he explains. "We generally used a 9- by 18-inch upright light table. The film (18 by 18 inches) was cut down the middle, and one person looked at the left side, another at the right. The difference between light tables then and now is like the difference between a Model T and a Porsche."

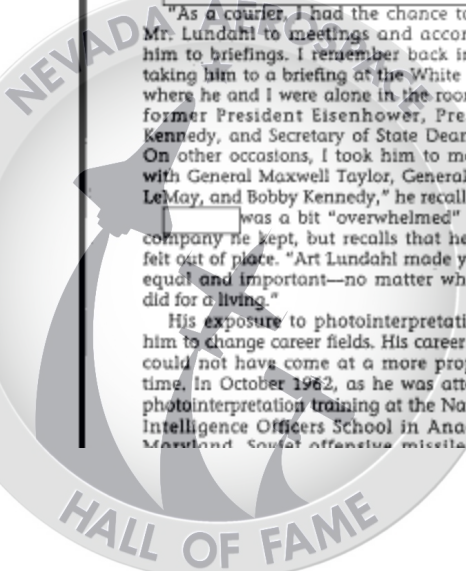
[redacted] long-term perspective has served the Center well in countless crises through the years, and the most recent international upheaval, Operation Desert Storm, was no exception. As a deputy division chief assigned to a near east division, [redacted] played a large part in forming IEG's Persian Gulf Task Force. "I was glad to be in the middle of the crisis. That's what this job is all about. Every IA hopes to work something like that in a career. I've been lucky; I have had several such assignments."

[redacted] believes that many employees stay at NPIC for the chance to make a historic contribution. "There is great excitement to this job. It is just plain exciting to discover things that will make history. The anticipation of a new find is what keeps you going."

[redacted] arrived at NPIC during the long, hot summer of 1961. He came to the Steuart Building to work in the photolab. In those days, the lab had only a small staff, and the photogeneralists, as they are known, were responsible for handling, delivering, and processing film.



[redacted] was not a newcomer to photography or photolabs. Prior to joining the National Center, he had spent five years as a photographer with the FBI. He was "lured" to



team. Once recruited, [redacted] was said. "I've never once been sorry I left the FBI. Working here at NPIC is the most incredibly exciting way to earn a living that I can imagine," he enthuses. "We are fortunate. We can see—and we have seen—the difference our work makes. We watched the Soviets flex their muscles 90 miles off the coast of Florida, and I am convinced that they went home with their tails between their legs because of NPIC's efforts."

The muscle-flexing that [redacted] speaks of is more widely known as the Cuban missile crisis. This incident of international brinkmanship began to unfold only a year after [redacted] entered on duty. Despite the passage of time, he remembers the crisis well and reflects upon it often.

"It was without a doubt the most memorable event of my career, and it was one of the most significant emotional events of my life," he declares. In his current position as NPIC's briefing officer, he has grown accustomed to retelling the story to countless tour groups and visitors.

Long, Hot Days

From August 1962 through early 1963, members of the small NPIC cadre worked feverishly to stay on top of the situation. "We were closeted in the Stuart Building, working 12-hour days, seven days a week, with no time off," [redacted] vividly recalls that the working environment left quite a bit to be desired. "The Stuart Building was God-awful hot and humid. It had poor ventilation and you couldn't open the windows. The photolab literally stunk from the chemicals."

Despite the hardships—or perhaps because of the hardships—imposed by the Cuban crisis, the men and women of NPIC were imbued with a stirring sense of mission, [redacted] recalls. "We never felt driven to put in more hours, we always felt it was a matter of choice. Most of us wouldn't have gone home even if someone had told us it was okay to do so. NPIC was where we wanted to be. We believed we held the mission together. Here we were—a small, ill-defined, rag-tag team able to provide the President with the intelligence necessary to stop nuclear destruction."

The NPIC veteran credits NPIC's founding director, Art Lundahl, with invoking the spirit de corps. "Mr. Lundahl was a shining example of professionalism. He was the quintessential role model."

Over the years, [redacted] has had ample opportunity to observe other international developments. Two historic episodes stand out in his mind: the North Korean seizure of the USS Pueblo in 1968 and the Iraqi rocket attack on the USS Stark in 1987. "When the Pueblo was seized by North Koreans, information existed that might have kept the crew from being captured and brutalized, but the wrong military response was used.

The incident taught me that no matter how good the intelligence, the political and/or military response must be right and it must be timely."

[redacted] contrasts the Pueblo failure with the USS Stark episode. "After the Stark was hit by Iraqi missiles and 37 sailors died, intelligence helped the ship make its way through the dangerous Strait of Hormuz back to home port in Florida. It proved to me that intelligence can work when it is used properly." If [redacted] needed additional proof, he received it about a year ago. He was briefing a group from the National War College and mentioned the Stark incident, when one of the audience members raised his hand and identified himself as a former Stark crew member. "He talked for about two hours about the crisis. He recounted the whole experience and his emotions at the time, and it was clear he credited the ship's safe return to intelligence."

[redacted] happily considers himself an NPIC "lifer." In 30 years, he never once worked outside NPIC—not even on a brief rotational assignment. And he has no plans to leave the Center now, with retirement just over a year away. But he voices no regret about his career choice. "There is no doubt in my mind that I made the right decision in staying here. This is the place to be."

Several current-day employees began working for NPIC before there was an NPIC. That is the case with [redacted] Deputy Chief of the Operations and Engineering Group. She entered on duty in December 1959—when NPIC was simply PIC (Photographic Interpretation Center). She arrived with a degree in mathematics, eager to work on math models and photomeasurements.



[redacted] entered an organization that was vastly different from the NPIC of today. Although she was a computer programmer, her first assignment predated modern automation. She worked in the hot and cramped PIC computer room on the sixth

floor of the Stuart Building. Her computer was the ALWAC III-E, an ancient model that operated on a vacuum-tube system with paper-tape input and output. The ALWAC was notable for its unwieldy size and frequent need of ad hoc maintenance—and for producing the measurements used in the Cuban missile crisis.

The early days were challenging in other ways as well. "The Stuart Building was in a rough neighborhood, and I was always a little uneasy. We were right across the street from a police station, and one morning I came to work and found that shots had been fired right through the windows of the sixth-floor computer room!"

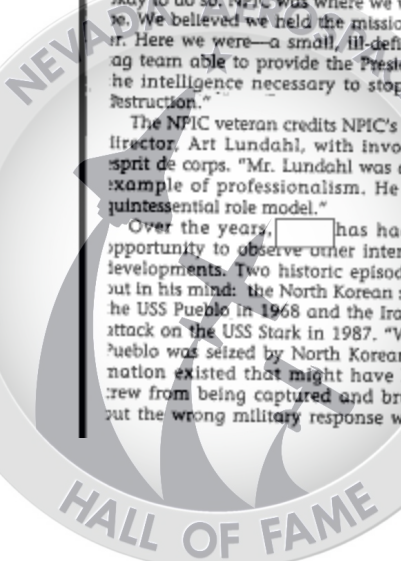
Tumultuous Times

In May of 1960, just months after [redacted] arrival, the U-2 piloted by Gary Powers was shot down over the Soviet Union, effectively blowing the lid off the reconnaissance operation. "We were all terribly upset, because now it was certain the Russians knew about the U-2 program. We didn't know whether or not the U-2 missions would continue." The missions did continue, as did PIC's growth and responsibilities. Less than a year later, National Security Council Intelligence Directive 8 was signed and the National Center was born. But by 1962, the new National Center would be plunged into a critical test of fortitude: the Cuban missile crisis.

The crisis had a profound impact on [redacted]. "We felt such pride as an organization. We had accomplished something that no other organization could accomplish—we had confirmed that the missiles in Cuba were offensive, rather than defensive," she says. "That was a thrilling time, because we were charting new territory. There was plenty of room for creativity, because there were no established rules or regulations. There was just an important job to do, and anybody would do anything that needed doing, for as many hours as required. We didn't have job descriptions back then."

The years that followed the Cuban missile crisis were troublesome for society as a whole and for CIA careerists in particular. "The 1960s were rough for me and for a lot of CIA officers. We felt we were special for having been selected to work for the CIA and we were proud of what we were doing, but at the same time there was a tremendous anti-CIA backlash in society. We couldn't defend our organization or correct misperceptions; we could only stand back and listen to disparaging remarks."

In the middle of that turbulent decade, [redacted] made a pivotal professional transition. In 1964, she stopped developing computer programs and became a section chief. It was a transition that came without warning. "One day my boss just came in and said, 'You are going to be the section chief for 18



Time Flies continued from page 15...

people. Here are their names.' I asked him, 'What do I do?' and he said, 'Act like a section chief.' I had taken no management training courses, but I figured I would try a few things, make some mistakes, and learn from them," she recalls.

[redacted] learned well and progressed through the managerial ranks—from branch chief all the way to group chief. She was the first NPIC woman to rise above the branch-chief level at NPIC, a fact that carried with it advantages and disadvantages. "Growing up in this organization, I had no female role models or peers. I didn't think of it as being difficult at the time, because I didn't know differently. But looking back, I think it was more difficult than I knew," she says. "Expectations were different back then, and there was a popular belief that management was a male purview. I think I was viewed differently because I had a degree in math and a technical background. I also think it was easier for me to move ahead because I worked in computer science, a field so new that there were no long-held traditions."

During the 1970s and 1980s, [redacted] witnessed a profound change in the roles of women in the workforce. "Women were accepted in positions of authority much more easily, and they had more options for balancing their families and work life, like day-care programs." In 1979, [redacted] became the first woman at NPIC to be promoted to the senior intelligence service (SIS) ranks. "At the time, there were less than a dozen SIS women in the entire Agency. Now, there are 80. That increase is very gratifying."

In addition to workforce changes, [redacted] also has observed many technological changes. "There has been a phenomenal change in technology in this organization. Back in 1961, we envisioned IAs doing their own computing and measurements right at their workstations. That vision was not accomplished until the modernization program of the 1980s. It took a lot longer than we thought it would, but I am still astounded by all the technological changes that have taken place," she says.

[redacted] has not stayed firmly planted at NPIC for the past 30 years. She spent three years on the Directorate of Science and Technology (DS&T) staff and two years on the Inspector General's staff. But she always intended to return to NPIC. "This place and this work gets in your blood," she enthuses. "NPIC has a very specific contribution to make. And this organization has been good to me. It's given me a lot of opportunities to grow and to develop, and I've made a lot of good friends."

[redacted] shares something in common with [redacted]. They worked together in the Stewart Building, calculating math models on the venerable ALWAC computers. [redacted] joined the Agency in 1956, working as

a cartographer in a location near Foggy Bottom; he joined NPIC in 1961 to work in photogrammetry.

Like [redacted] he shares some colorful memories of the Stewart Building. "It was a crummy neighborhood and had a real parking problem. We would park on the street, and every couple of hours we had to go move our cars to make sure they weren't ticketed." [redacted] car never was.)



One afternoon in 1962, as [redacted] was getting ready to go home, a PI entered the office to doublecheck the measurement of a crate. [redacted] stayed an extra couple of hours to get the job done and didn't think much more about it. Days later, he discovered that measurement—which happened to be of a crate in Cuba—had landed on President Kennedy's desk. That was [redacted] introduction to the Cuban missile crisis and to high-stakes intelligence.

Massive Measurements

The weeks that followed brought long nights, 12-hour shifts, and a massive number of measurements. Through it all, [redacted] maintained a sense of perspective. "I really never felt afraid or threatened by the prospect of war—maybe I was just too dumb to feel that way. It was a busy time and you just did your job."

Although it is not apparent from his low-key approach, [redacted] has lived through amazing times in photointerpretation history. He remembers only too well the first time he saw photographs taken by the U-2. "I was amazed by how much territory the U-2 covered. You would look at a ship on the water and realize how small it was and how high the U-2 was flying." He still recalls the time he watched a U-2 take off. "It went only a short distance on the runway and then took off at a 45-degree angle. Then it was quickly out of sight. That was something to see." Later, he witnessed the takeoff of the SR-71.

Advances in reconnaissance systems have paralleled advances in [redacted] work area. "We moved from paper-tape machines to

punch-card computers to electronic computers. When we moved to Building 213, I had to learn the Univac computer, a whole new system. That was the beginning of my programming career." The learning process has never stopped for [redacted]. "Now I am learning how to program the Macintosh personal computer for small-utility mensuration programs."

With advanced systems came an influx of new people and a new work environment. "It used to be that I knew 50 percent of the people here; now, I'm lucky if I know five percent. And I'm the oldest guy in my division. It gives me a father complex, but I guess it keeps me young," he quips.

[redacted] has never felt compelled to look for career opportunities outside NPIC. "I like working here, and I knew there was no place else where I could do this type of work. Plus, the people are great. They care a lot about the mission and they are dedicated to doing a good job."

In 30 years, has he ever been bored? "Sure, there are days when my job gets boring, but I stick with it because I like solving problems," he says. "Around here, it is challenging just to keep up with the technology, so I am always learning a new system. I just keep plugging along." □

Thirtysomething

NPIC can boast of having several "founding" members—pioneers who have been with the organization since 1961 (or longer) and who remain active among our ranks. In addition to the four employees featured in "Time Flies" (page 14), the 30-plus club includes:



Two former Army officers, who were assigned to NPIC in 1961, also have stayed on board all these years:



This information was supplied primarily by Personnel Division. □

NEVADA

HALL OF FAME

Lundahl continued from page 9...

ng defensive lines. It seemed like a medieval /igw.

We must be careful. We have been training our PIs all these years to learn what the state of technology is—let's say in nuclear gases diffusion plants. We know what they look like in the US or in England. But in Iraq and some Middle Eastern countries, they use techniques that had been tried, perfected, and rejected by the US many years ago. Therefore, it is very difficult to find elements of these nuclear programs, because we're thinking in terms of the 20th century.

We are going to have to pay particular attention: to the animosity between India and Pakistan; to North Korea; to Libya; to the other sleeping giant, Syria; as well as to Iran, Iraq, and a dozen or more countries. We also must pay close attention to rapidly developing Soviet provinces. Will they have their own weapon systems? Will they have their own communications systems, their own KGB? We cannot make any implicit assumptions about these new provinces.

"Photography is the only thing we've come up with that stops time. Literally."

Given the rapid changes in technology and in the world itself, does photointelligence retain its importance? What is the true value of the photographic image?

There is no question that photointelligence will continue to be extremely important in the future. Wherever there is a big event, photography will be called for. I would predict more demands on photography for economic purposes. Not just to determine the status of crops and the infrastructure, but to tell something about the industrial base. And we've got many other places to study in addition to the Soviet Union. It's clear now that the "hot wars" in the year 2000 and beyond will transpire into very big economic wars.

In the overall concern about the preservation of the environment, photography will help us decide what is happening. Photography must help in world disaster situations—fires, earthquakes, chemical or nuclear disasters. It also will be a prime mover in helping people recover.

Photography is the only thing we've come up with that stops time. Literally. You can take thin or thick slices of time and lay them before you, magnify them, measure them, enhance them, and do many other things. Photography pierces barriers to humans—things that are too far away, too small or too large, too fast or too slow. And at NPIC, we're always reaching for a synergistic effort, where the total is greater than the sum of the parts.

It is my impression and conviction that NPIC will continue to grow in importance under effective leadership and the continuing dedication of the kind of people that we've had for the past 30 years. We've come a long way, and we've compiled a marvelous record. □

NPIC's Living Museum

As government office space goes, the reception area outside the NPIC auditorium has a distinctly personal feel to it. Notably absent is the customary institutional blandness—the gray-on-beige look. Instead, those who enter the room find an inviting suite decorated in muted shades of plum. But the auditorium anteroom provides more than color and comfort. It also offers a front-row view of history.

The Lundahl Room, as it is known, houses the medals, medallions, and honors that highlight the career of Arthur C. Lundahl, NPIC's founding Director. The room is something of a museum, but it is not an off-limits archive. Instead, it is a meeting-and-greeting area for scores of employees and visitors who come to the auditorium nearly every day of the week.

Most visitors are drawn to the softly lit display case that houses the impressive artifacts of Lundahl's career. Inside, neatly displayed, is Lundahl's emblem of membership in the Most Excellent Order of the British Empire; NPIC's first Director was knighted in 1974 by Her Royal Highness Queen Elizabeth II. Also on display are a National Security Medal, awarded to the former Director in 1973 by President Richard M. Nixon; the Pioneer in Space Award, presented in 1985 by President Ronald W. Reagan; a Distinguished Intelligence Medal from CIA; an Exceptional Service Medal from DIA; and an award from the Defense Mapping Agency Topographic Center. In addition to medals, the display case also contains photographs (including an autographed photo of Kelly

Johnson, the U-2 designer) and a silver calendar, designed by Tiffany's, highlighting the critical days of the October 1962 Cuban missile crisis. President John F. Kennedy had 12 of these calendars made and presented them to his closest advisers; Lundahl was among them.

Amidst the array of colorful photographs, awards, and medals, one might easily miss a note, signed by Mr. Lundahl, which states simply: 'These honors were made to my name, but they truly represent honors paid to the Building 213 Family—each and every one of you—for your notable accomplishments. I am proud to have received them for you.' □

NEVADA

HALL OF FAME

and 30th



and 30th Anniversary





and 30

NPIC Trivia Game

1. Which President signed the bill making NPIC a national center?
2. How many Directors has NPIC had over the years?
3. What is the total number of divisions currently at NPIC?
4. Where was NPIC's first "home"?
5. How many official visitors does NPIC receive a year (not counting Open House visitors)?
6. Which, if any, US presidents have visited NPIC?
7. How big is Building 213 (in square feet)?
8. How many square feet of carpeting cover NPIC's floors?
9. How many Macintosh computers can be found at NPIC?
10. How much ink does the printshop use in a year (in pounds)?
11. How many miles of network cable run through Building 213?
12. How many Deputy Directors has NPIC had?
13. In round numbers, how many people have graduated from the National Imagery Analysis Course since 1978?
14. How many DCIs have visited NPIC?
15. Which floor of Building 213 has undergone the most extensive renovation?
16. How many elevators are there in Building 213?
17. Why is there a stairwell in front of Building 213?
18. How many vaults are in NPIC?
19. How many viewgraph frames does the supply room hand out in a year?
20. What floor of Building 213 houses the most employees?
21. How many groups does NPIC have?
22. How many CIA secretaries are assigned to NPIC?
23. On average, how many pounds of silver does the photolab recover from film processing in a year?
24. How many telephones (commercial and secure) are in Building 213?
25. How many haircuts are given at NPIC per week?
26. How many Sun workstations are located in Building 213?
27. How many SIS officers are assigned to NPIC?
28. How many CIA-owned copiers does NPIC have?
29. How many Wangs are "on line" in Building 213?
30. What is the average number of meals NPIC's cafeteria serves per day?

1. President Eisenhower. 2. Six. 3. 38 divisions. 4. The top floors of the Stewart Motor Car Company, 5th and K Streets, NW. 5. On average, NPIC hosts about 3,000 official visitors each year. 6. George Bush visited PEG as Vice President. No President has visited while in office. 7. It measures 433,600 square feet, with a 58,800-square-foot annex. 8. About 592,600 square feet. 9. As of 1 October 1991, there were 562 "Mac's." 10. 1,820 pounds, on average. 11. Trivia Question: The exact number is unknown, but there is more than enough cable to go from here to Moscow and back. 12. We've had 10 Deputies. 13. Over 1,000. 14. Six. 15. The first floor. 16. 10; the elevator shaft outside has no remaining elevator components, so it is not included. 17. Originally this stairwell/elevator was used by US Geological Survey for access to their sixth-floor offices. It remained after their departure, but the elevator shaft was modified to serve as a storage area. The emergency egress stairway from the sixth floor and the roof still remains, as well. 18. Officially, 104, but the number fluctuates with renovations. 19. About 10,400! 20. The fifth floor, home to both ITAC and DIA. 21. Seven groups. 22. 69 CIA secretaries. 23. 130 pounds of silver, or an estimated \$8,528 worth. 24. 4,528 at last count. 25. 111 haircuts. 26. As of 1 October 1991, there were 866 Suns, but this is a "living figure" and the count changes regularly. 27. 31 as of the last SIS promotion cycle. 28. An estimated 56. 29. 720 Wangs. 30. 2,000 meals!

NEVADA AEROSPACE

HALL OF FAME

and 30th Anniversary

Historic Headlines

For the past 30 years, 18 January—NPIC's charter date—has been newsworthy for many reasons, as these headlines from The New York Times show:

- 1961: Eisenhower's Farewell Address Sees Threat to Liberties in Vast Defense Machine
- 1962: Dominican Republic's Junta, Rafael Rodriguez Echavarria Ousted
- 1963: US Favors Sea Missiles, Not Land, to Shield Italy
- 1964: Panama Imposes Complete Break; US Aides Depart
- 1965: President Johnson Plans 88 New Projects to Fight Poverty at the Cost of \$101,960,782; Approved by Congress
- 1966: McNamara to Ask 113,000 More Men for the Military
- 1967: Saigon Proposes Talks With Hanoi to Extend Truce
- 1968: Johnson's Budget \$186 Billion, He Wants Gold Reserve Freed, Seeks an Assurance by Hanoi
- 1969: France Proposes Big 4 UN Envoys Meet on Mideast, Diplomats Feel Suggestion Brings Paris Closer to US and Soviet Positions
- 1970: Air Pollution is Following Population to the Suburbs
- 1971: Army Spied on 18,000 Civilians in 2-Year Operation. [Information about 18,000 American civilians, mainly those who opposed the Vietnam War, reportedly was fed into Army files.]
- 1972: Mujib Orders Guerrillas to Give Up All Weapons, Sheik Mujibur Rahman Acts to Halt Disorder Among the Bengalis
- 1973: Thieu Reported to be Objecting on 4 Key Issues, Snags Said to Include POWs and Truce Supervision But Not Broad Outlines of Accord
- 1974: Egypt and Israel Reach Accord on Separation of Canal Forces; A Pact to Open Suez is Reported
- 1975: Peking Prepares New Constitution
- 1976: Lebanese Planes Attack Leftists and Palestinians, Intervention by the Military in Moslem-Christian Strife, Army Accused by PLO
- 1977: Gilmore is Executed After Stay is Upset; "Let's Do It!" He Said; Firing Squad Ends 10-Year Halt in Death Penalty
- 1978: Experts Dispute [Carter] Administration, Doubt World Oil Shortage in 1980s
- 1979: Carter Issues Plea to Khomeini to Give Iran Chief a Chance, Ayatollah Urges Backers to Press, Fight on . . . Arms Sales to Go on, President Says Monitoring of Soviet Missiles Will Remain Adequate
- 1980: US Plans Embargo on Iran on Its Own as Allies Shun Idea, Europeans Cite Trade Laws, Soviet Intervention in Afghanistan Limit Steps Against Teheran
- 1981: Iran and US Seek to Clarify Terms for Freeing Hostages; Banks Agree to Compromise, Debt Called an Issue, Lawsuits May be Dropped if Some Overdue Loans are Repaid at Once
- 1982: Mercury Sinks to 0, Season's Low in New York City, Century's Worst Cold Persists
- 1983: President is Urged to Press Japanese for Freer Trade, Industry and Union Chiefs Give Views to Reagan on Eve of Talks With Nakasone
- 1984: A Hong Kong Plan Detailed by China, Aide Says "Time Is Ripe" for an Accord on Colony's Future
- 1985: "Right to Die" Rule in Terminal Cases Widened in Jersey, State's High Court Acts, Declares All Steps to Prolong a Patient's Life, Including Feeding, Can be Halted
- 1986: Tank Battle Puts Lebanese Nearer to Full Civil War, Moslems Fight Gemayel, Militias Attempt Advance on Christian President's Town
- 1987: Inquiry Into NSC Uncovering Little About Iran Deals, White House Panel Described as Lacking Access to Key People and Documents
- 1988: New Election Held by Haiti Leaders; Vote Appears Low, Boycott is Widespread, Many Irregularities are Seen
- 1989: Baker Asserts US Should Not "Rush" in Aiding Moscow, Favors Gorbachev Plans, Secretary-Designate Outlines Goals in Foreign Policy
- 1990: Greater Reliance on Foreign Oil Feared as US Output Tumbles, Production Decline Last Year was Largest Ever
- 1991: Iraqis Fire Missiles at Small Israeli Cities After Second Day of Allied Bombing; US Discourages an Israeli Response

NEVADA AEROSPACE

HALL OF FAME

and 30th Anniversary

How Do You Think NPIC Will Change Over the Next 30 Years?

"In the next 30 years, we won't be looking at film anymore; we'll be looking at television sets. There won't be any film left."

"In 30 years there will be no need to separate PEG, ISG, and NPIC. The Center will merge these groups and run on a 24-hour schedule."

"Speaking strictly from a Support Group [SG] point of view, I see SG growing with the needs of NPIC."

"NPIC will move into an era of near-total, computer-aided, interactive (voice, tool), and imagery exploitation with near-instantaneous dissemination."

"DoD will take charge of NPIC and move it to a DoD building. NPIC will be smaller and you'll see a woman director after Leo's tenure."

"As long as NPIC remains 'The National Center,' I believe we will evolve into an even more diverse organization than we are today, with our major emphasis placed on economic, environmental, and military issues."

"There will be more of a focus on environmental and economic issues."

"It [NPIC] will be much smaller, due to downsizing and the world being less hostile."

"I would like to think that there will be major changes at NPIC, but I really don't believe that much will change. Oh, we will most likely be using new computers and be exploiting everything in soft copy, but these are superficial changes. NPIC still will be involved with providing intelligence to policymakers much as we are today. The big bad bear may be a friend by then, but somebody else will step up to the challenge."

"People will be dying to come here over the next few years. Because of the shrinking of the Poles and the movement of the icebergs, NPIC will probably become the keeper of ecological studies."

"Well, we won't be moving to West Virginia in that time! I think we will redirect intelligence issues to focus more on what was the USSR, not less because of the breakup. In terms of the workforce, women will gain the majority at NPIC by the next 30 years."

"I believe that NPIC will have moved from this building and that there will be a much more diverse workforce."

"PEG management will change hands 30 times . . ."

"We'll have had more building upgrades—15 new carpets in the main hall. We'll all be livin' in the wilds of West Virginia. We'll either still be fighting the Soviet Union or will have made them the 51st state, over the District! We still won't have any parking (even in West Virginia) and IEG will have reorganized 4,000 times!"

"We'll have a different workforce—a multicolored patchwork of employees and more minorities in upper management—as a result of the current multicultural push. The general workforce will become more 'enlightened,' intellectually, educationally, and racially. With the development of the waterfront, Building 213 is going to be the place in the Agency to work . . . all those five-star restaurants!"

"There will be more computerized equipment, and all the imagery will be on laser disk. The cans and flat imagery will no longer exist."

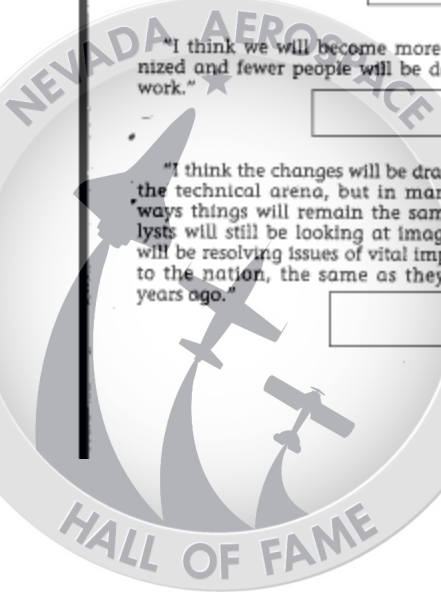
"Hopefully, for the better."

"I think we will become more mechanized and fewer people will be doing the work."

"We'll be out of this Building in 10 to 15 years. NPIC under DoD management will be more modest with a more limited charter than it has now."

"I think the changes will be dramatic in the technical arena, but in many other ways things will remain the same. Analysts will still be looking at imagery and will be resolving issues of vital importance to the nation, the same as they did 30 years ago."

"When you look at the changes over the last 30 years and factor in the recent dramatic geopolitical changes and technology explosion, it makes it difficult, if not impossible, to predict change. However, some things will remain constant: [redacted] will be exploitation division centers and we will still be at Building 213."



and 30th Anniversary

50 Years Ago



Harbor View: This aerial shot of Pearl Harbor was taken on 26 November 1941, only days before the attack.

EARLY IN THE MORNING OF 7 DECEMBER 1941, an estimated 200 Japanese warplanes descended upon Pearl Harbor, Hawaii, attacking the US Pacific Fleet. When the attack was over, more than 2,300 lives had been lost. The devastating raid traumatized the nation, and, in the words of Japanese General Tojo, "awakened the great sleeping

giant." On 8 December, the US declared war on Japan.

"Pearl Harbor day" truly did live on in infamy. When President Dwight D. Eisenhower took office, he expressed grave concern that "gaps" in intelligence estimates could leave the United States vulnerable again. And, based on his World War II expe-

riences, he professed the belief that aerial reconnaissance could serve as a valuable source of warning against surprise attack. His conviction in the value of photointelligence led the CIA to establish a Photo Intelligence Division, the predecessor to the modern-day NPIC.

The rest, as they say, is history. □

Acknowledgments

The Communications Resources Staff wishes to acknowledge the following individuals and components who helped compile this special publication:



And all the employees, managers, and "alumni" who agreed enthusiastically to be interviewed or to provide ideas or photos for these pages. □

NEVADA AEROSPACE

HALL OF FAME